

VIGOUR

we offer solutions regarding your ideas!

ULTRA HIGH PURITY GAS SYSTEM

**Gas
Control
Solutions**

Elgiloy® is registered trademark of Elgiloy Specialty Metals.
Hastelloy® is registered trademark of Haynes International, Inc.
Viton® and Kalrez® are registered trademarks of Dupont.
VespeI® is registered trademark of Dupont Specialty Metals.

Table Of Contents |

VIGOUR

Regulators for UHP Application | P1~42

VSR-50UB / UC Series	p1~4
VSR-100UB / UC Series	p5~8
VSR-1000UB / UC Series	p9~12
VSR-210UB / UC Series	p13~16
VSR-410UB / UC Series	p17~20
VSR-510UB / UC Series	p21~24
VSR-610UB / UC Series	p25~28
VSR-710UB / UC Series	p29~32
VSR-910UB Series	p33~34
VSR-911UB Series	p35~36
VSR-920UB / UC Series	p37~40
VSR-930UB Series	p41~42

Diaphragm Valve | P43~84

VDV32UB / UC Series	p43~46
VDV33UB / UC Series	p47~52
VDV40UB / UC Series	p53~56
VDV42UB / UC Series	p57~60
VDV52UB / UC Series	p61~64
VDV22UB Series	p66
VDV36UB / UC Series	p67~70
VDV46UB / UC Series	p71~74
VDV48UB / UC Series	p75~78
VDV37UB / UC Series	p79~82
VDV38UB / UC Series	p83~86
VDV39UB Series	p87~88

Bellows Valve | P89~92

VUBV Series	p89~90
VUBV2 Series	p91~92

Metering Bellows Valve | P93~94

VBMV Series	p93~94
-------------	--------

Metering Valve | P95~97

VMV Series	p95~97
------------	--------

Atomic Layer Deposition Valve | P98

VALD Series	p98
-------------	-----

Vacuum Generator | P99~104

VVG Series	p99~100
VGV1 Series	p101~102
VGV2 Series	p103~104

All-Welded Check Valve | P105

VUCV Series	p105
-------------	------

Check Valve | P106

VCVH Series	p106
-------------	------

Adjustable Check Valve | P107

VCA Series	p107
------------	------

Gas Stick Assemblie | P108~110

VUP Series	p108~110
------------	----------

Filter | P111~113

VUF Series	p111~112
VFH Series	p113

Gasket Filter | P114

VUGF Series	p114
-------------	------

Flow Switch | P115~117

VEFS1 Series	p115
VEFS2 Series	p117

VFS face seal fitting | P118~133

VVR Series	p118~130
HVVR Series	p131~133

Micro Weld Fitting | P134~137

VMW Series	p134~137
------------	----------

Tube Butt Weld Fitting | P138~140

VTW Series	p138~140
------------	----------

Weld Assemblie | P141

VWR Series	p141
------------	------

Cylinder Connection | P142~144

VUC Series	p142
VUC DISS Series	p143~144

Gauge | P145~148

Process Specification | P149~153

Single Stage Pressure Regulator

VSR-50UB Series

Product Feature

- Single-stage pressure regulator
- 10µin. Ra surface finish (25µin. Ra optional)
- Minimized internal volume for short purge times
- All materials used meet ASTM A479 / A484 / A276 standards
- Internal connectors for pressure gauges
- Flow capacity: to 15 slpm (standard), to 30 slpm (optional)
- 100% helium-leak-tested



Dimensions (mm)

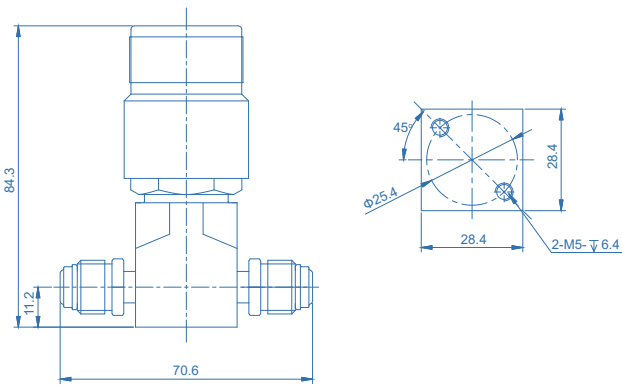

Flowchart

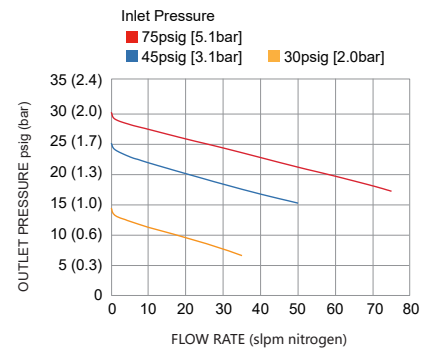
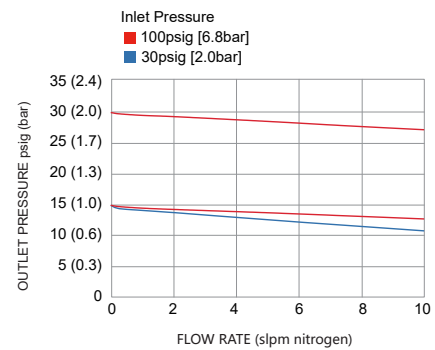

Technical Data

Type:	single-stage
Inlet pressure P1:	150 psig (10bar)
Outlet pressure P2:	Vac to 10/30/60/100 psig (0.7/2/4/7bar)
Surface finish:	10µin. Ra (25µin. Ra optional)
Materials	
Body:	see ordering info
Valve seat:	PCTFE (VespeI® optional)
Diaphragm:	Hastelloy® C276
Inlets and Outlets:	1/4" VFS fitting and tube weld
Temperature range:	-40°F to +160°F (-40°C to +71°C)
Leak rate: (to atmosphere)	1x10 ⁻⁹ mbar·l/s He
(via seat)	1x10 ⁻⁸ mbar·l/s He
Flow capacity:	Cv=0.06 (Cv=0.1 optional)
Supply pressure effect:	0.2 psig rise in delivery pressure per 20 psig source pressure drop @Cv=0.06 0.4 psig rise in delivery pressure per 20 psig source pressure drop @Cv=0.1
Weight:	approx. 0.5kg (depending on connections or options)

Single Stage Pressure Regulator VSR-50UB Series

Ordering Information

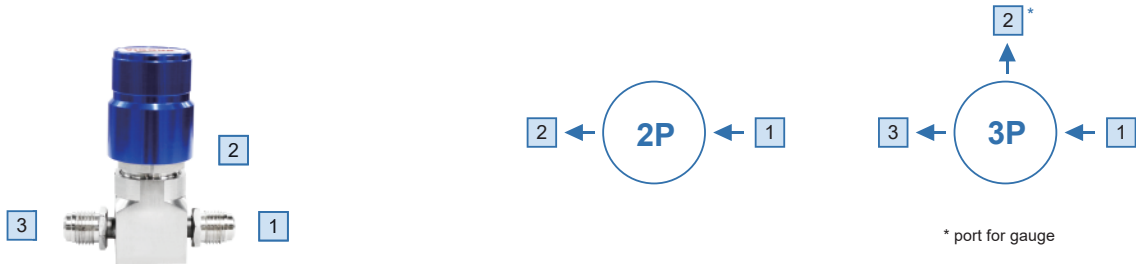

Inlet/outlet Connection

FV4: 1/4" VFS female | TW4: 1/4" tube weld
MV4: 1/4" VFS male | P: gauge (1/4" VFS fitting)

* Other connection standard, consult factory

Port Selection

VSR - 50UBS - 10 - 7 - 3P - 1 - 2 - 3 - R25 - HF - VS - P

Materials

S: 316L
SHP: 316L body and nozzle
Hastelloy® C22 poppet

* All options diaphragm material is Hastelloy® C276

Inlet Pressure

10: 150 psig

Port Config

2P: 2 ports
3P: 3 ports

Outlet Pressure

V0.7: Vac to 10 psig*
V2: Vac to 30 psig*
V4: Vac to 60 psig*
V7: Vac to 100 psig*
0.7: to 10 psig *
2: to 30 psig
4: to 60 psig
7: to 100 psig

* With the V option, the negative pressure can not be adjusted, only the pressure gauge shows the negative pressure.

Process Specification

None: VS001B
P: VS001A

* For details, please refer to the appendix.

Valve seat Option

None: PCTFE
VS: VespeI®

Cv Option

None: Cv=0.06
HF: Cv=0.1

Surface Finish

None: 10 µin. Ra
R25: 25 µin. Ra

Ordering Example

VSR - 50UBS - 10 - 7 - FV4 - P - FV4



Single Stage Pressure Regulator

VSR-50UC Series

Product Feature

- Single-stage pressure regulator
- 10µin Ra average surface finish (10µin. Ra max, 7µin. Ra max. 5µin. Ra max optional)
- Minimized internal volume for short purge times
- All materials used meet ASTM A479 / A484 / A276 standards
- Internal connectors for pressure gauges
- Flow capacity: to 15 slpm (standard), to 30 slpm (optional)
- 100% helium-leak-tested



Dimensions (mm)

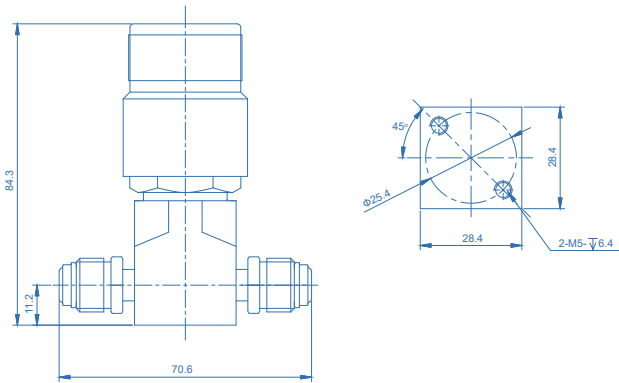

Flowchart

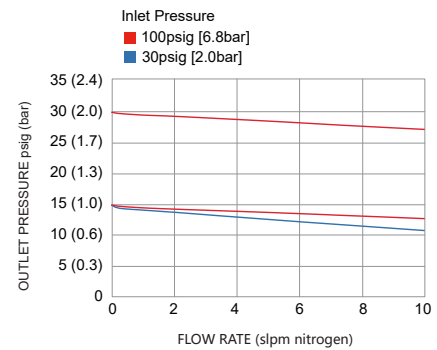

Technical Data

Type:	single-stage
Inlet pressure P ₁ :	150 psig (10bar)
Outlet pressure P ₂ :	Vac to 10/30/60/100 psig (0.7/2/4/7bar)
Surface finish:	10µin Ra average surface finish (10µin. Ra max, 7µin. Ra max. 5µin. Ra max optional)

Materials	
Body:	see ordering info
Valve seat:	PCTFE (Vespe ^l optional)
Diaphragm:	Hastelloy [®] C276
Inlets and Outlets:	1/4" VFS fitting and tube weld
Temperature range:	-40°F to +160°F (-40°C to +71°C)
Leak rate: (to atmosphere)	1x10 ⁻⁹ mbar·l/s He
(via seat)	1x10 ⁻⁸ mbar·l/s He
Flow capacity:	Cv=0.06 (Cv=0.1 optional)
Supply pressure effect:	0.2 psig rise in delivery pressure per 20 psig source pressure drop @Cv=0.06 0.4 psig rise in delivery pressure per 20 psig source pressure drop @Cv=0.1
Weight:	approx. 0.5kg (depending on connections or options)

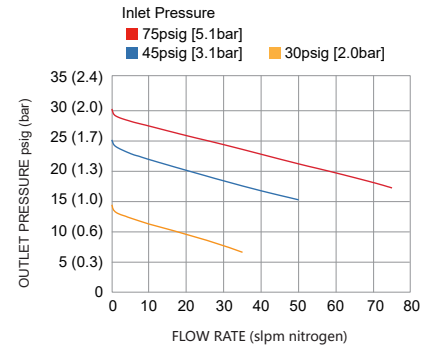

Single Stage Pressure Regulator VSR-50UC Series

Ordering Information

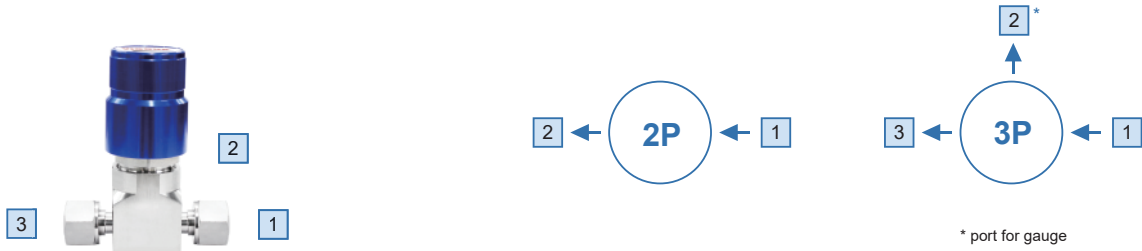

Inlet/outlet Connection

FV4: 1/4" VFS female | TW4: 1/4" tube weld
 MV4: 1/4" VFS male | P: gauge (1/4" VFS fitting)

* Other connection standard, consult factory

Port Selection

VSR - 50UCSLV - 10 - 7 - 3P - 1 - 2 - 3 - R5 - HF - VS - P

Materials

SLV: 316L secondary remelt
 SHP: 316L body and nozzle
 Hastelloy® C22 poppet

*All options diaphragm material is Hastelloy® C276

Inlet Pressure

10: 150 psig

Port Config

2P: 2 ports
 3P: 3 ports

Outlet Pressure

V0.7: Vac to 10 psig*
 V2: Vac to 30 psig*
 V4: Vac to 60 psig*
 V7: Vac to 100 psig*
 0.7: to 10 psig *
 2: to 30 psig
 4: to 60 psig
 7: to 100 psig

* With the V option, the negative pressure can not be adjusted, only the pressure gauge shows the negative pressure.

Process Specification

P: VS001A
 * For details, please refer to the appendix.

Valve seat Option

None: PCTFE
 VS: Vespel®

Cv Option

None: Cv=0.06
 HF: Cv=0.1

Surface Finish

None: 10 µin. Ra max
 R7: 7 µin. Ra max
 R5: 5 µin. Ra max

Ordering Example

VSR - 50UCSLV - 10 - 7 - FV4 - P - FV4



Single Stage Pressure Regulator

VSR-100UB Series

Product Feature

- Single-stage pressure regulator
- 10µin. Ra surface finish (25µin. Ra optional)
- Minimized internal volume for short purge times
- All materials used meet ASTM A479 / A484 / A276 standards
- Internal connectors for pressure gauges
- Flow capacity: to 30 slpm (standard), to 120 slpm (optional)
- High control accuracy
- Metal-to-metal seal to atmosphere
- Simple outlet pressure limitation by hand-wheel
- 100% helium-leak-tested



Dimensions (mm)

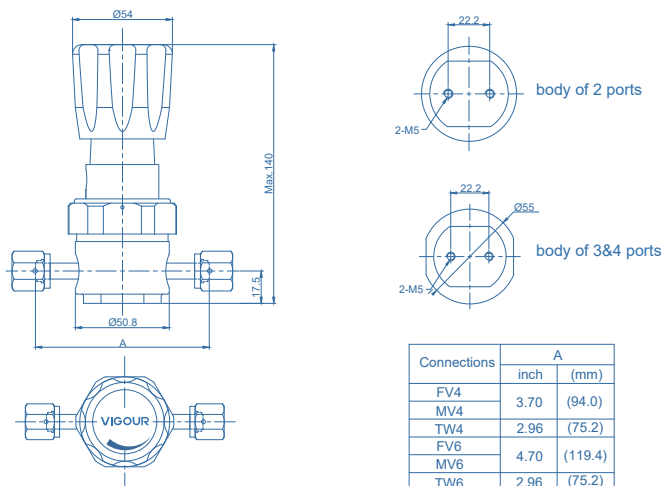

Technical Data

Type:	single-stage
Inlet pressure P ₁ :	Max. 3500 psig (250bar)
Outlet pressure P ₂ :	Vac to 10/30/60/100/150 psig (0.7/2/4/7/10bar)
Proof pressure:	5000 psig (340bar)
Burst pressure:	10000 psig (690bar)
Surface finish:	10µin. Ra (25µin. Ra optional)
Materials	
Body:	see ordering info
Valve seat:	PCTFE (VespeI® optional)
Diaphragm:	Hastelloy® C276
Inlets and Outlets:	1/4" / 3/8" VFS fitting and tube weld
Bonnet port:	1/8" NPT (on panel mount option, bonnet port is not threaded)
Temperature range:	-40°F to +160°F (-40°C to +71°C)
Leak rate: (to atmosphere)	1x10 ⁻⁹ mbar·l/s He
(via seat)	1x10 ⁻⁸ mbar·l/s He
Flow capacity:	Cv=0.09 (Cv=0.15 optional)
Supply pressure effect:	0.35 psig rise in delivery pressure per 100 psig source pressure drop @Cv=0.09 0.5psig rise in delivery pressure per 100 psig source pressure drop @Cv=0.15
Weight:	approx. 1.35kg (depending on connections or options)

Flowchart

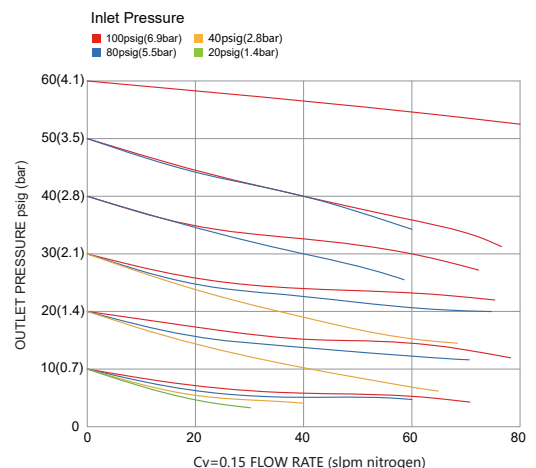
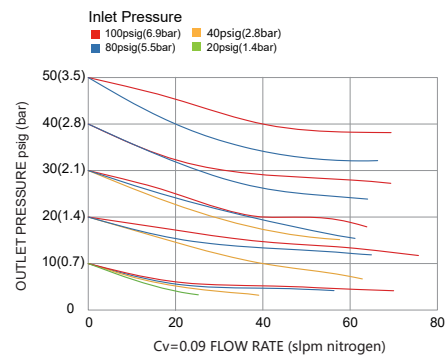
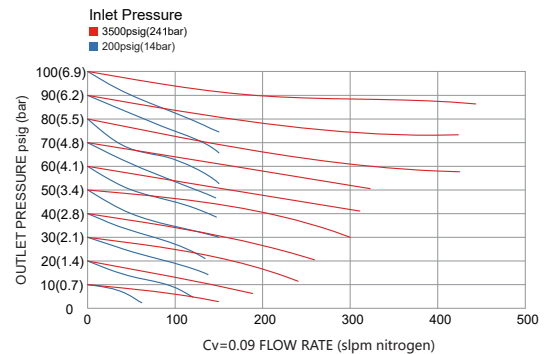

Single Stage Pressure Regulator VSR-100UB Series

Ordering Information

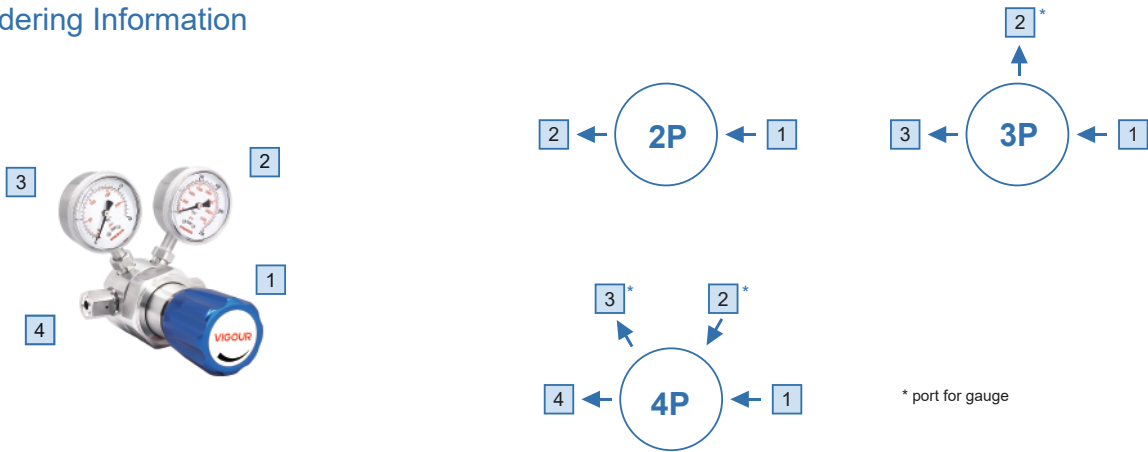

Inlet/outlet Connection

FV4: 1/4" VFS female
MV4: 1/4" VFS male
FV6: 3/8" VFS female
MV6: 3/8" VFS male

IFV4: 1/4" (gauge female threaded connection machined on the body)
TW4: 1/4" tube weld
TW6: 3/8" tube weld

P: gauge (1/4" VFS fitting)
IP: gauge (IFV4 fitting)

* Other connection standard, consult factory

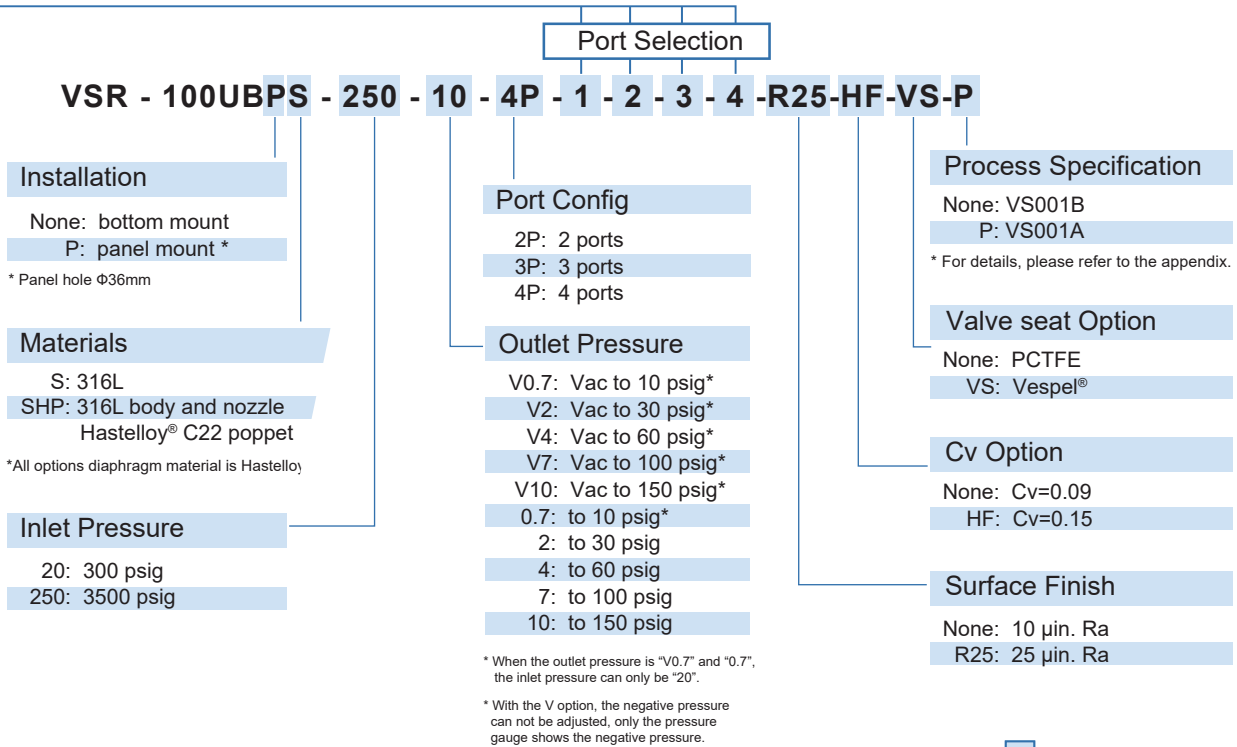

Ordering Example

VSR - 100UBS - 250 - 10 - FV4 - P - P - FV4

1 - 2 - 3 - 4



Single Stage Pressure Regulator

VSR-100UC Series

Product Feature

- Single-stage pressure regulator
- 10µin Ra average surface finish (10µin. Ra max, 7µin. Ra max, 5µin. Ra max optional)
- Minimized internal volume for short purge times
- All materials used meet ASTM A479 / A484 / A276 standards
- Internal connectors for pressure gauges
- Flow capacity: to 30 slpm (standard), to 120 slpm (optional)
- High control accuracy
- Metal-to-metal seal to atmosphere
- Simple outlet pressure limitation by hand-wheel
- 100% helium-leak-tested



Dimensions (mm)

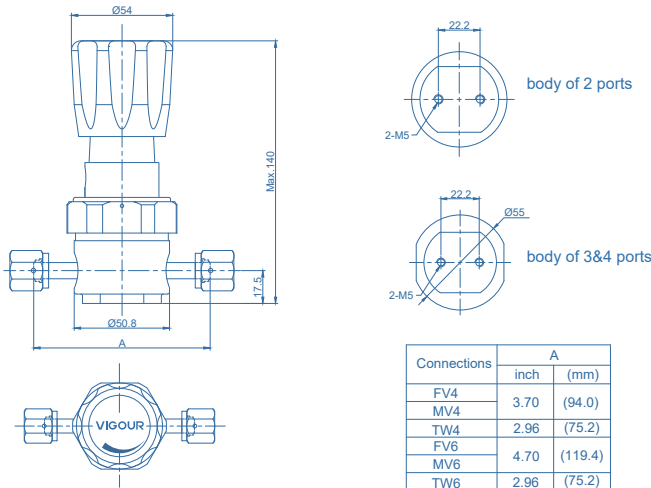

Technical Data

Type:	single-stage
Inlet pressure P1:	Max. 3500 psig (250bar)
Outlet pressure P2:	Vac to 10/30/60/100/150 psig (0.7/2/4/7/10bar)
Surface finish:	10µin Ra average surface finish (10µin. Ra max, 7µin. Ra max, 5µin. Ra max optional)
Materials	
Body:	see ordering info
Valve seat:	PCTFE (VespeI® optional)
Diaphragm:	Hastelloy® C276
Inlets and Outlets:	1/4" / 3/8" VFS fitting and tube weld
Bonnet port:	1/8" NPT (on panel mount option, bonnet port is not threaded)
Temperature range:	-40°F to +160°F (-40°C to +71°C)
Leak rate: (to atmosphere)	1x10 ⁻⁹ mbar·l/s He
(via seat)	1x10 ⁻⁸ mbar·l/s He
Flow capacity:	Cv=0.09 (Cv=0.15 optional)
Supply pressure effect:	0.35 psig rise in delivery pressure per 100 psig source pressure drop @Cv=0.09 0.5psig rise in delivery pressure per 100 psig source pressure drop @Cv=0.15
Weight:	approx. 1.35kg (depending on connections or options)

Flowchart

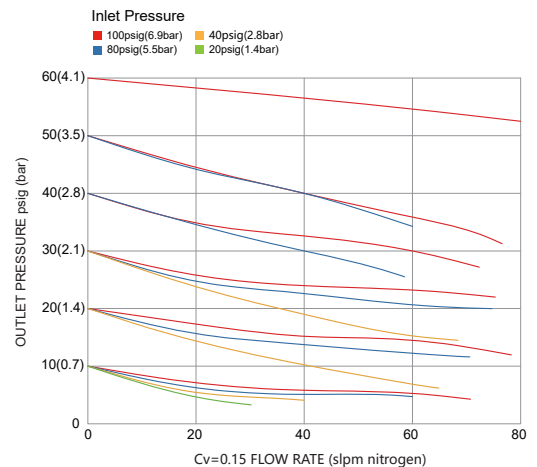
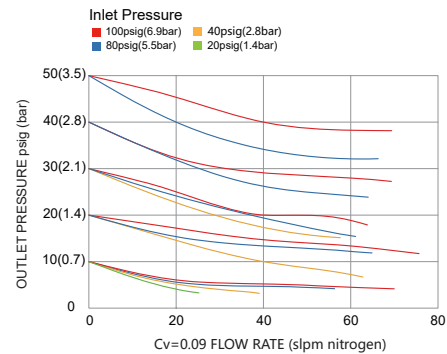
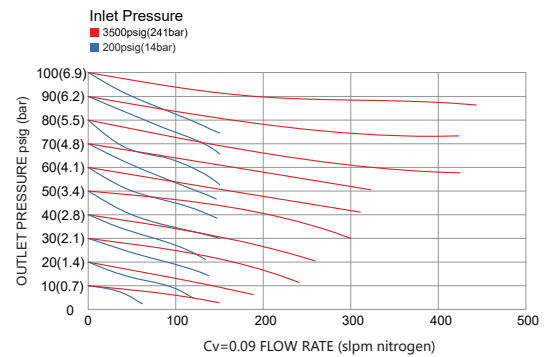

Single Stage Pressure Regulator VSR-100UC Series

Ordering Information

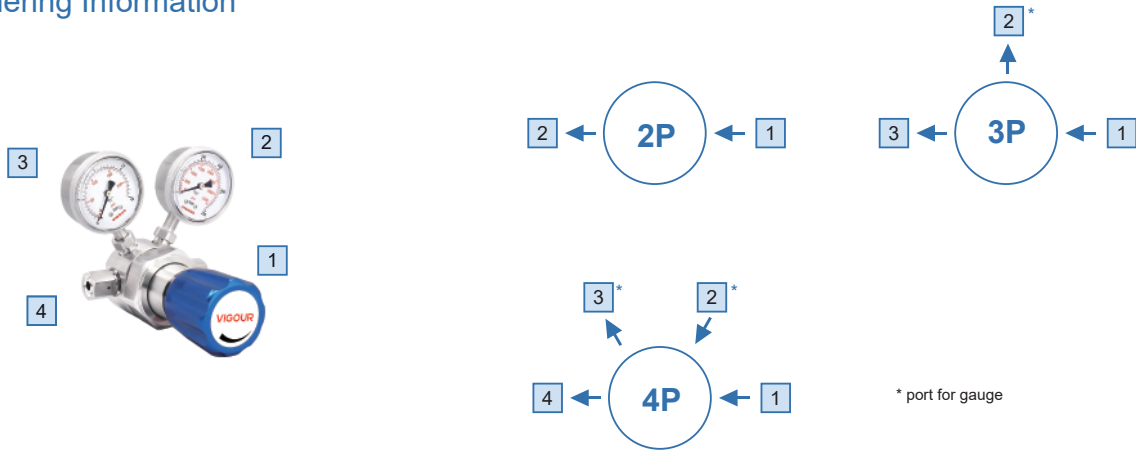

Inlet/outlet Connection

FV4: 1/4" VFS female
MV4: 1/4" VFS male
FV6: 3/8" VFS female
MV6: 3/8" VFS male

IFV4: 1/4" (gauge female threaded connection machined on the body)
TW4: 1/4" tube weld
TW6: 3/8" tube weld

P: gauge (1/4" VFS fitting)
IP: gauge (IFV4 fitting)

* Other connection standard, consult factory

Port Selection

VSR - 100UCPSLV - 250 - 10 - 4P - 1 - 2 - 3 - 4 - R5 - HF - VS - P

Installation

None: bottom mount
P: panel mount

* Panel hole $\Phi 36\text{mm}$

Materials

SLV: 316L secondary remelt body
316L poppet and nozzle
SH: 316L secondary remelt body
Hastelloy® C22 internals
SHP: 316L secondary remelt body
Hastelloy® C22 poppet
316L nozzle
H: Hastelloy® C22 body and internals

*All options diaphragm material is Hastelloy® C276

Inlet Pressure

20: 300 psig
250: 3500 psig

Port Config

2P: 2 ports
3P: 3 ports
4P: 4 ports

Outlet Pressure

V0.7: Vac to 10 psig*
V2: Vac to 30 psig*
V4: Vac to 60 psig*
V7: Vac to 100 psig*
V10: Vac to 150 psig*
0.7: to 10 psig*
2: to 30 psig
4: to 60 psig
7: to 100 psig
10: to 150 psig

* When the outlet pressure is "V0.7" and "0.7", the inlet pressure can only be "20".

* With the V option, the negative pressure can not be adjusted, only the pressure gauge shows the negative pressure.

Process Specification

P: VS001A

* For details, please refer to the appendix.

Valve seat Option

None: PCTFE
VS: Vespel®

Cv Option

None: Cv=0.09
HF: Cv=0.15

Surface Finish

None: 10 $\mu\text{in. Ra max}$
R7: 7 $\mu\text{in. Ra max}$
R5: 5 $\mu\text{in. Ra max}$

Ordering Example

VSR - 100UCSLV - 250 - 10 - 4P - FV4 - P - P - FV4

1 - 2 - 3 - 4



Single Stage Pressure Regulator

VSR-1000UB Series

Product Feature

- Single-stage pressure regulator
- 10µin. Ra surface finish (25µin. Ra optional)
- Minimized internal volume for short purge times
- All materials used meet ASTM A479 / A484 / A276 standards
- Internal connectors for pressure gauges
- Flow capacity: to 30 slpm (standard), to 120 slpm (optional)
- High control accuracy
- Metal-to-metal seal to atmosphere
- Simple outlet pressure limitation by hand-wheel
- 100% helium-leak-tested



Dimensions (mm)

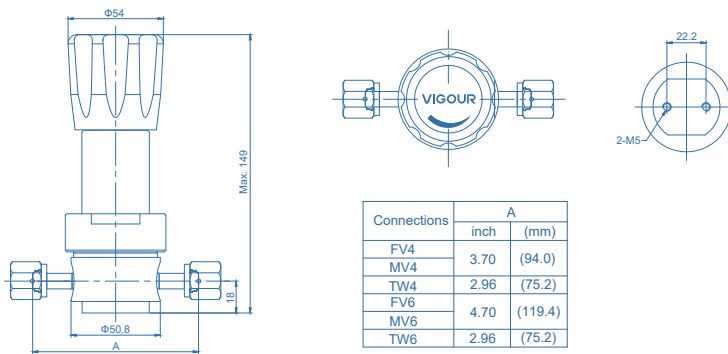

Technical Data

Type:	single-stage
Inlet pressure P ₁ :	Max. 3500 psig (250bar)
Outlet pressure P ₂ :	Vac to 10/30/60/100/150 psig (0.7/2/4/7/10bar)
Proof pressure:	5000 psig (340bar)
Burst pressure:	10000 psig (690bar)
Surface finish:	10µin. Ra (25µin. Ra optional)
Materials	
Body:	see ordering info
Valve seat:	PCTFE (VespeI® optional)
Diaphragm:	Hastelloy® C276
Inlets and Outlets:	1/4" / 3/8" VFS fitting and tube weld
Bonnet port:	1/8" NPT (on panel mount option, bonnet port is not threaded)
Temperature range:	-40°F to +160°F (-40°C to +71°C)
Leak rate: (to atmosphere)	1x10 ⁻⁹ mbar·l/s He
(via seat)	1x10 ⁻⁸ mbar·l/s He
Flow capacity:	Cv=0.09 (Cv=0.15 optional)
Supply pressure effect:	0.35 psig rise in delivery pressure per 100 psig source pressure drop @Cv=0.09 0.5psig rise in delivery pressure per 100 psig source pressure drop @Cv=0.15
Weight:	approx. 1.35kg (depending on connections or options)

Flowchart

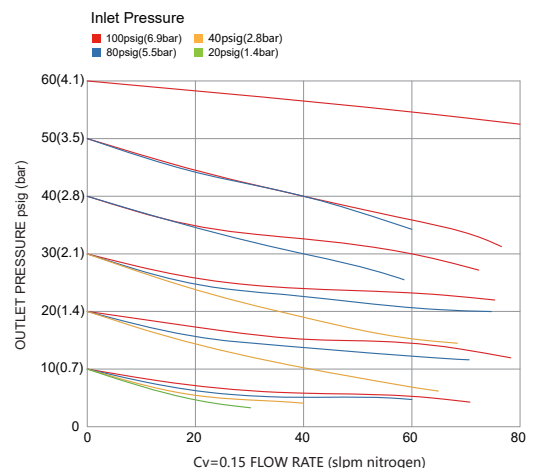
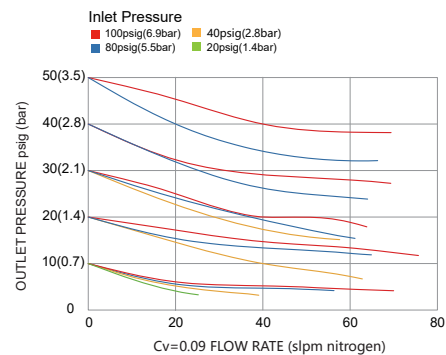
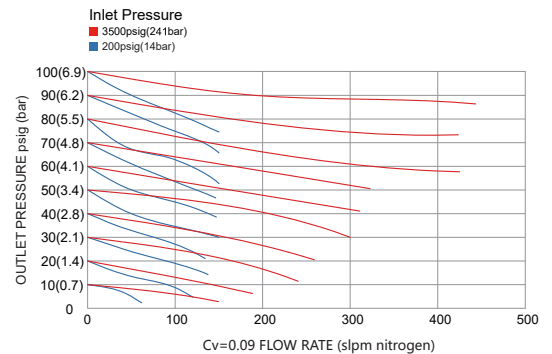

Single Stage Pressure Regulator VSR-1000UB Series

Ordering Information

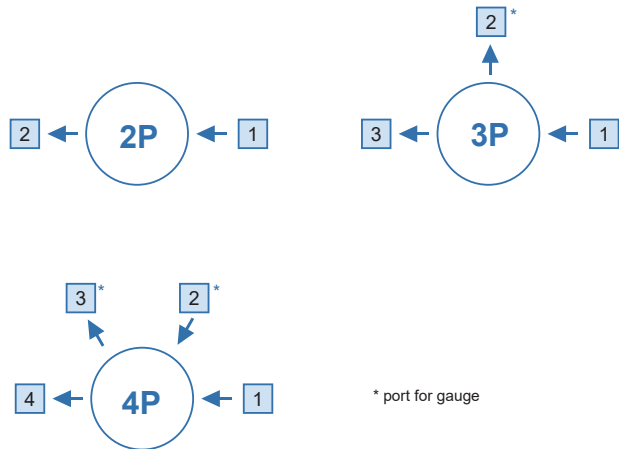

Inlet/outlet Connection

FV4: 1/4" VFS female
MV4: 1/4" VFS male
FV6: 3/8" VFS female
MV6: 3/8" VFS male

IFV4: 1/4" (gauge female threaded connection machined on the body)
TW4: 1/4" tube weld
TW6: 3/8" tube weld

P: gauge (1/4" VFS fitting)
IP: gauge (IFV4 fitting)

* Other connection standard, consult factory

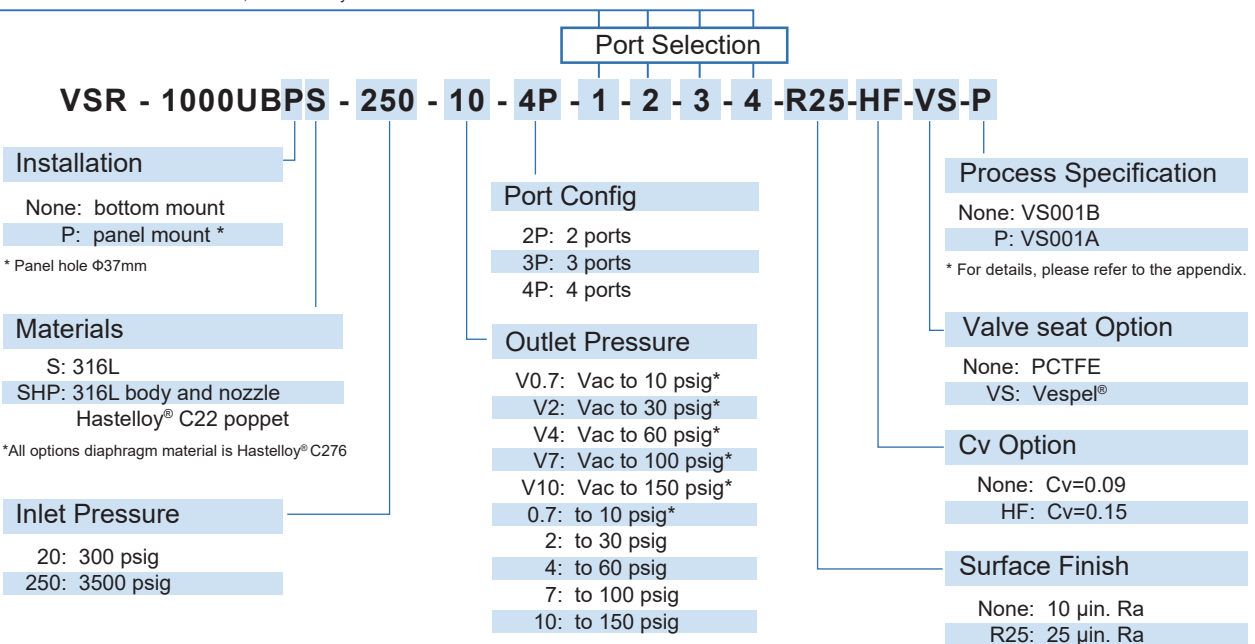

* When the outlet pressure is "V0.7" and "0.7", the inlet pressure can only be "20".

* With the V option, the negative pressure can not be adjusted, only the pressure gauge shows the negative pressure.

Ordering Example

VSR - 1000UBS - 250 - 10 - FV4 - P - P - FV4



Single Stage Pressure Regulator

VSR-1000UC Series

Product Feature

- Single-stage pressure regulator
- 10µin Ra average surface finish (10µin. Ra max, 7µin. Ra max. 5µin. Ra max optional)
- Minimized internal volume for short purge times
- All materials used meet ASTM A479 / A484 / A276 standards
- Internal connectors for pressure gauges
- Flow capacity: to 30 slpm (standard), to 120 slpm (optional)
- High control accuracy
- Metal-to-metal seal to atmosphere
- Simple outlet pressure limitation by hand-wheel
- 100% helium-leak-tested



Dimensions (mm)

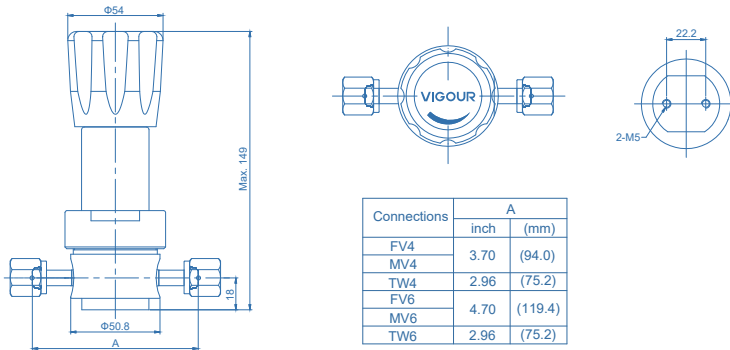

Technical Data

Type:	single-stage
Inlet pressure P1:	Max. 3500 psig (250bar)
Outlet pressure P2:	Vac to 10/30/60/100/150 psig (0.7/2/4/7/10bar)
Surface finish:	10µin Ra average surface finish (10µin. Ra max, 7µin. Ra max, 5µin. Ra max optional)
Materials	
Body:	see ordering info
Valve seat:	PCTFE (VespeI® optional)
Diaphragm:	Hastelloy® C276
Inlets and Outlets:	1/4" / 3/8" VFS fitting and tube weld
Bonnet port:	1/8" NPT (on panel mount option, bonnet port is not threaded)
Temperature range:	-40°F to +160°F (-40°C to +71°C)
Leak rate: (to atmosphere)	1x10 ⁻⁹ mbar·l/s He
(via seat)	1x10 ⁻⁸ mbar·l/s He
Flow capacity:	Cv=0.09 (Cv=0.15 optional)
Supply pressure effect:	0.35 psig rise in delivery pressure per 100 psig source pressure drop @Cv=0.09 0.5psig rise in delivery pressure per 100 psig source pressure drop @Cv=0.15
Weight:	approx. 1.35kg (depending on connections or options)

Flowchart

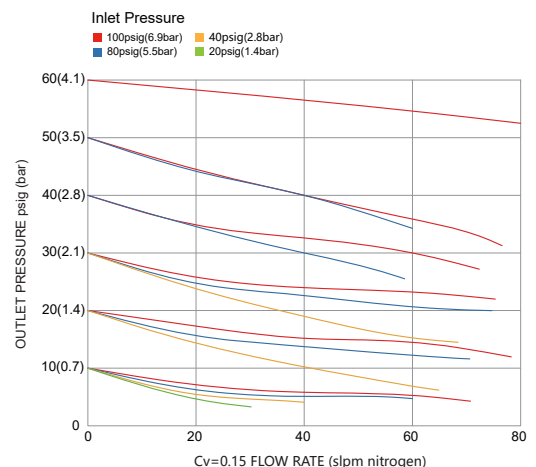
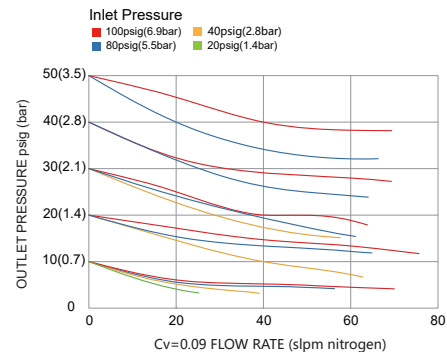
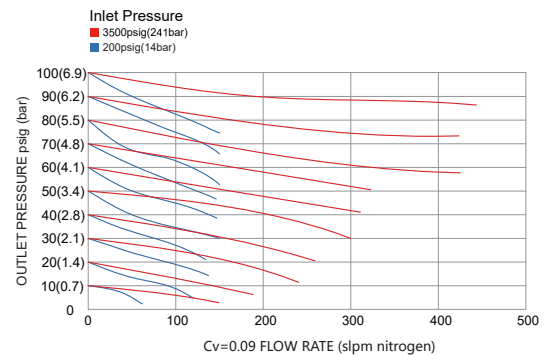

Single Stage Pressure Regulator VSR-1000UC Series

Ordering Information

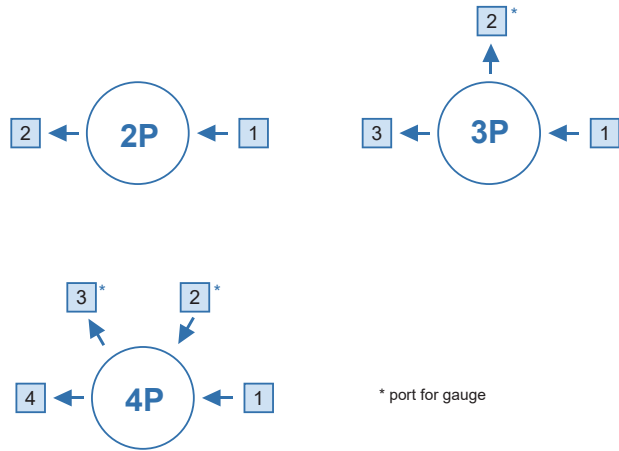

* port for gauge

Inlet/outlet Connection

FV4: 1/4" VFS female
MV4: 1/4" VFS male
FV6: 3/8" VFS female
MV6: 3/8" VFS male

IFV4: 1/4" (gauge female threaded connection machined on the body)
TW4: 1/4" tube weld
TW6: 3/8" tube weld

P: gauge (1/4" VFS fitting)
IP: gauge (IFV4 fitting)

* Other connection standard, consult factory

Port Selection

VSR - 1000UCPSLV - 250 - 10 - 4P - 1 - 2 - 3 - 4 - R5-HF-VS-P

Installation

None: bottom mount
P: panel mount

* Panel hole Φ 37mm

Materials

SLV: 316L secondary remelt body
316L poppet and nozzle
SH: 316L secondary remelt body
Hastelloy® C22 internals
SHP: 316L secondary remelt body
Hastelloy® C22 poppet
316L nozzle
H: Hastelloy® C22 body and internals

*All options diaphragm material is Hastelloy® C276

Inlet Pressure

20: 300 psig
250: 3500 psig

Port Config

2P: 2 ports
3P: 3 ports
4P: 4 ports

Outlet Pressure

V0.7: Vac to 10 psig*
V2: Vac to 30 psig*
V4: Vac to 60 psig*
V7: Vac to 100 psig*
V10: Vac to 150 psig*
0.7: to 10 psig*
2: to 30 psig
4: to 60 psig
7: to 100 psig
10: to 150 psig

* When the outlet pressure is "V0.7" and "0.7", the inlet pressure can only be "20".

* With the V option, the negative pressure can not be adjusted, only the pressure gauge shows the negative pressure.

Process Specification

P: VS001A

* For details, please refer to the appendix.

Valve seat Option

None: PCTFE
VS: Vespel®

Cv Option

None: Cv=0.09
HF: Cv=0.15

Surface Finish

None: 10 μ m. Ra max
R7: 7 μ m. Ra max
R5: 5 μ m. Ra max

Ordering Example

VSR - 1000UCSLV - 250 - 10 - 4P - FV4 - P - P - FV4
1 - 2 - 3 - 4



Single Stage Pressure Regulator

VSR-210UB Series

Product Feature

- Single-stage pressure regulator
- 10µin. Ra surface finish (25µin. Ra optional)
- Minimized internal volume for short purge times
- All materials used meet ASTM A479 / A484 / A276 standards
- Internal connectors for pressure gauges
- Force compensation has wider flow capacity
- High control accuracy
- Metal-to-metal seal to atmosphere
- Simple outlet pressure limitation by hand-wheel
- 100% helium-leak-tested
- Tied-diaphragm design



Dimensions (mm)

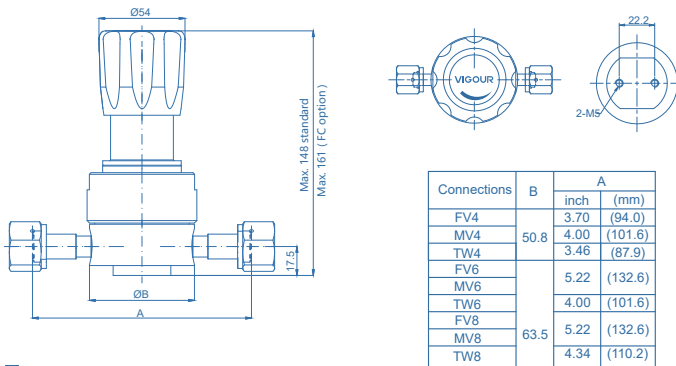

Technical Data

Type:	single-stage
Inlet pressure P ₁ :	Max. 3000 psig (200bar)
Outlet pressure P ₂ :	Vac to 30/60/100/150/250 psig (2/4/7/10/17bar)
Proof pressure:	2550 psig (175bar)
Burst pressure:	8000 psig (550bar)
Surface finish:	10µin. Ra (25µin. Ra optional)
Materials	
Body:	see ordering info
Valve seat:	PCTFE (Vespe [®] optional)
Diaphragm:	Hastelloy [®] C276
Inlets and Outlets:	1/4" / 3/8" or 1/2" VFS fitting or tube weld
Bonnet port:	1/8" NPT(F) (on panel mount option, bonnet port is not threaded)
Temperature range:	-40°F to +160°F (-40°C to +71°C)
Leak rate: (to atmosphere)	1x10 ⁻⁹ mbar·l/s He
(via seat)	1x10 ⁻⁸ mbar·l/s He
Flow capacity:	Cv=0.65, Cv=1.1 (HF option)
Supply pressure effect:	3.5 psig rise in delivery pressure per 100 psig source pressure drop
	4.2 psig rise in delivery pressure per 100 psig source pressure drop (FC option)
Weight:	approx. 2.0kg (depending on connections or options)

Flowchart

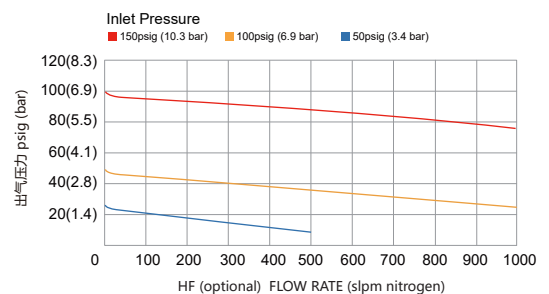
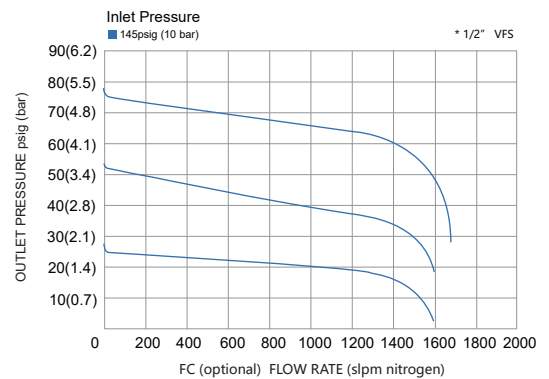
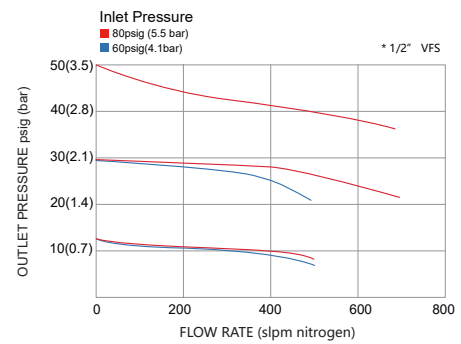

Single Stage Pressure Regulator VSR-210UB Series

Ordering Information

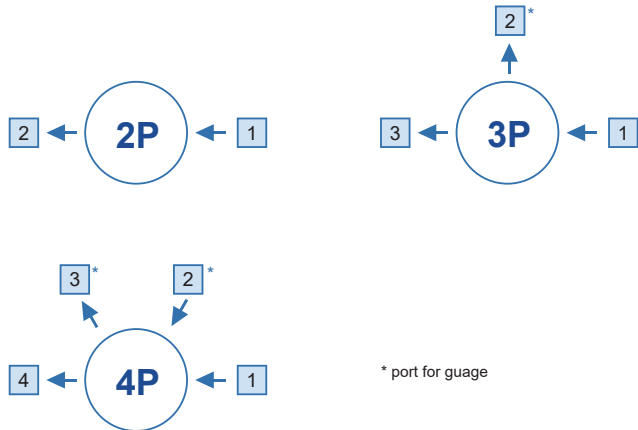

Inlet/Outlet Connection

FV4: 1/4" VFS female MV4: 1/4" VFS male FV6: 3/8" VFS female MV6: 3/8" VFS male	FV8: 1/2" VFS female MV8: 1/2" VFS male FV12: 3/4" VFS female MV12: 3/4" VFS male	IFV4: 1/4" (gauge female threaded connection machined on the body) TW4: 1/4" tube weld TW6: 3/8" tube weld	TW8: 1/2" tube weld TW12: 3/4" tube weld P: gauge (1/4" VFS fitting) IP: gauge (IFV4 fitting)
--	--	--	--

* Other connection standard, consult factory

Port Selection

VSR - 210UBPS - 117 - V4 - 4P - 1 - 2 - 3 - 4 - R25-HF-FC-VS-P

Installation

None: bottom mount
P: panel mount

* Panel hole Ø37mm

Materials

S: 316L
SHP: 316L body
Hastelloy® C22 poppet

*All options diaphragm material is Hastelloy® C276

Inlet Pressure

20: 300 psig
117: 1700 psig (standard)
200: 3000 psig*

* Not available with outlet pressure:
V2 / V4 / 2 / 4

Port Config

2P: 2 ports
3P: 3 ports
4P: 4 ports

Outlet Pressure

V2: Vac to 30 psig*
V4: Vac to 60 psig*
V7: Vac to 100 psig*
V10: Vac to 150 psig*
2: to 30 psig
4: to 60 psig
7: to 100 psig
10: to 150 psig
P17: Preset to 250 psig*

* 250 psig outlet pressure preset at
800 psig (55 bar) inlet pressure.

* With the V option, the negative pressure
can not be adjusted, only the pressure
gauge shows the negative pressure.

Process Specification

None: VS001B
P: VS001A

* For details, please refer to the appendix.

Valve seat Option

None: PCTFE
VS: VespeI®

Option

FC: Force compensation

* Force compensation feature inlet
pressure Max. 300 psig

* FC option is available with
connection size 1/2 or 3/4 inch

* Not available with outlet pressure:
V2 / V4 / 2 / 4

* connection size 3/4 inch
pressure Max. 2400 psig

Cv Option

None: Cv=0.65
HF: Cv=1.1

Surface Finish

None: 10 µin. Ra
R25: 25 µin. Ra

Ordering Example

VSR - 210UBS - 117 - V4 - 2P - MV4 - MV4
1 - 2



Single Stage Pressure Regulator

VSR-210UC Series

Product Feature

- Single-stage pressure regulator
- 10µin Ra average surface finish (10µin. Ra max, 7µin. Ra max. 5µin. Ra max optional)
- Minimized internal volume for short purge times
- All materials used meet ASTM A479 / A484 / A276 standards
- Internal connectors for pressure gauges
- Force compensation has wider flow capacity
- High control accuracy
- Metal-to-metal seal to atmosphere
- Simple outlet pressure limitation by hand-wheel
- 100% helium-leak-tested
- Tied-diaphragm design



Dimensions (mm)

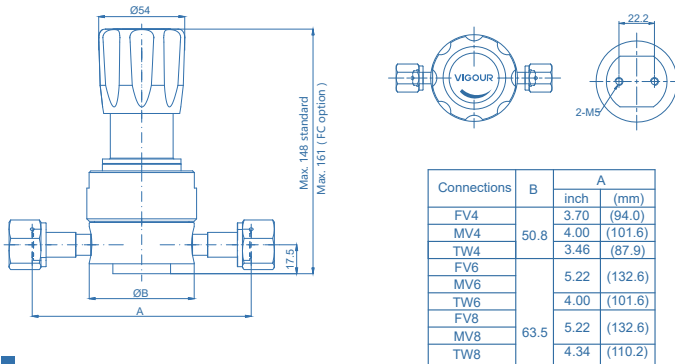

Technical Data

Type:	single-stage
Inlet pressure P1:	Max. 3000 psig (200bar)
Outlet pressure P2:	Vac to 30/60/100/150/250 psig (2/4/7/10/17bar)
Surface finish:	10µin Ra average surface finish (10µin. Ra max, 7µin. Ra max, 5µin. Ra max optional)
Materials	
Body:	see ordering info
Valve seat:	PCTFE (VespeI® optional)
Diaphragm:	Hastelloy® C276
Inlets and Outlets:	1/4" / 3/8" / 1/2" or 3/4" VFS fitting or tube weld
Bonnet port:	1/8" NPT(F) (on panel mount option, bonnet port is not threaded)
Temperature range:	-40°F to +160°F (-40°C to +71°C)
Leak rate: (to atmosphere)	1x10 ⁻⁹ mbar-l/s He
(via seat)	1x10 ⁻⁸ mbar-l/s He
Flow capacity:	Cv=0.65, Cv=1.1 (HF option)
Supply pressure effect:	3.5 psig rise in delivery pressure per 100 psig source pressure drop 4.2 psig rise in delivery pressure per 100 psig source pressure drop (FC option)
Weight:	approx. 2.0kg (depending on connections or options)

Flowchart

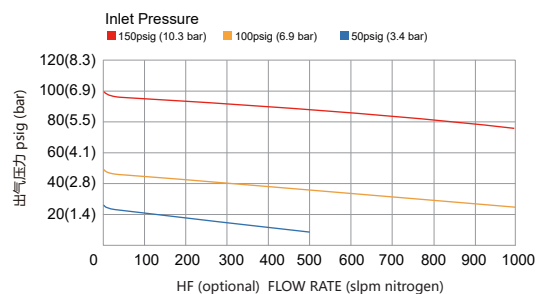
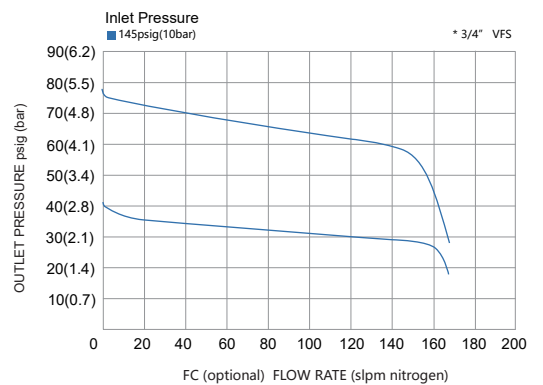
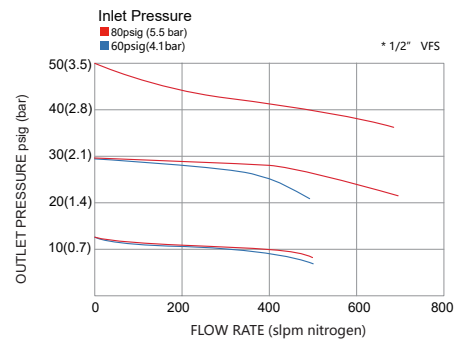

Single Stage Pressure Regulator VSR-210UC Series

Ordering Information

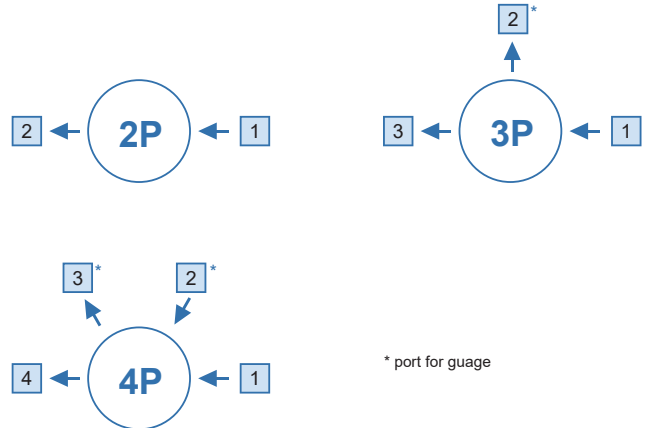

Inlet/outlet Connection

FV4: 1/4" VFS female	FV8: 1/2" VFS female	IFV4: 1/4" (gauge female threaded connection machined on the body)	TW8: 1/2" tube weld
MV4: 1/4" VFS male	MV8: 1/2" VFS male	TW4: 1/4" tube weld	TW12: 3/4" tube weld
FV6: 3/8" VFS female	FV12: 3/4" VFS female	TW6: 3/8" tube weld	P: gauge (1/4" VFS fitting)
MV6: 3/8" VFS male	MV12: 3/4" VFS male		IP: gauge (IFV4 fitting)

* Other connection standard, consult factory

Port Selection

VSR - 210UCPSLV-117-V4-4P- 1 - 2 - 3 - 4 - R5-HF-FC-VS-P

Installation

None: bottom mount
P: panel mount

* Panel hole Φ 37mm

Materials

SLV: 316L secondary remelt body
316L poppet and nozzle
SH: 316L secondary remelt body
Hastelloy® C22 internals
SHP: 316L secondary remelt body
Hastelloy® C22 poppet
316L nozzle

*All options diaphragm material is Hastelloy® C276

Inlet Pressure

20: 300 psig
117: 1700 psig (standard)
200: 3000 psig*

* Not available with outlet pressure:
V2 / V4 / 2 / 4

Port Config

2P: 2 ports
3P: 3 ports
4P: 4 ports

Outlet Pressure

V2: Vac to 30 psig*
V4: Vac to 60 psig*
V7: Vac to 100 psig*
V10: Vac to 150 psig*
2: to 30 psig
4: to 60 psig
7: to 100 psig
10: to 150 psig
P17: Preset to 250 psig*

* 250 psig outlet pressure preset at
800 psig (55 bar) inlet pressure.

* With the V option, the negative pressure
can not be adjusted, only the pressure
gauge shows the negative pressure.

Process Specification

P: VS001A

* For details, please refer to the appendix.

Valve seat Option

None: PCTFE
VS: Vespel®

Option

FC: Force compensation

* Force compensation feature inlet
pressure Max. 300 psig

* FC option is available with
connection size 1/2 or 3/4 inch

* Not available with outlet pressure:
V2 / V4 / 2 / 4

* connection size 3/4 inch
pressure Max. 2400 psig

Cv Option

None: Cv=0.65
HF: Cv=1.1

Surface Finish

None: 10 μ m. Ra max
R7: 7 μ m. Ra max
R5: 5 μ m. Ra max

Ordering Example

VSR - 210UCSLV - 117 - V4 - 2P - MV4 - FV4



Single Stage Pressure Regulator

VSR-410UB Series

Product Feature

- Single-stage pressure regulator
- 10µin. Ra surface finish (25µin. Ra optional)
- Minimized internal volume for short purge times
- All materials used meet ASTM A479 / A484 / A276 standards
- Internal connectors for pressure gauges
- High control accuracy
- Metal-to-metal seal to atmosphere
- Simple outlet pressure limitation by hand-wheel
- 100% helium-leak-tested
- Tied-diaphragm design
- Sub-atmospheric pressure delivery optional



Dimensions (mm)

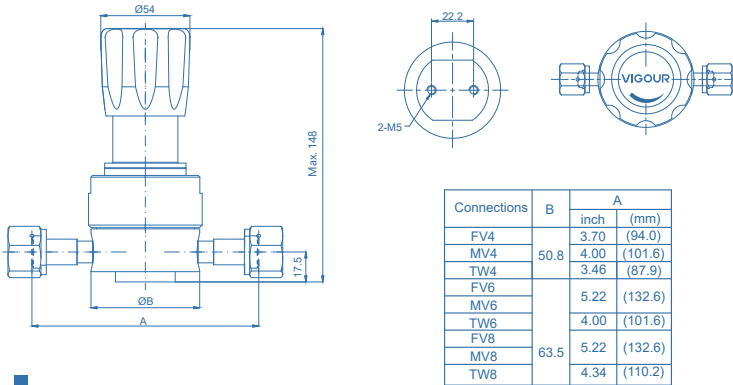

Technical Data

Type:	single-stage
Inlet pressure P1:	Max. 3000 psig (200bar)
Outlet pressure P2:	Vac to 30/60/100/150 psig (2/4/7/10bar)
Prosf pressure:	4000 psig (275bar)
Burst pressure:	8000 psig (550bar)
Surface finish:	10µin. Ra (25µin. Ra optional)
Materials	
Body:	see ordering info
Valve seat:	PCTFE (Vespel® optional)
Diaphragm:	Hastelloy® C276
Inlets and Outlets:	1/4" / 3/8" or 1/2" VFS fitting or tube weld
Bonnet port:	1/8" NPT(F) (on panel mount option, bonnet port is not threaded)
Temperature range:	-40°F to +160°F (-40°C to +71°C)
Leak rate: (to atmosphere)	1x10 ⁻⁹ mbar·l/s He
(via seat)	1x10 ⁻⁸ mbar·l/s He
Flow capacity:	Cv=0.45
Supply pressure effect:	1.6 psig rise in delivery pressure per 100 psig source pressure drop
Weight:	approx. 2.1kg (depending on connections or options)

Flowchart

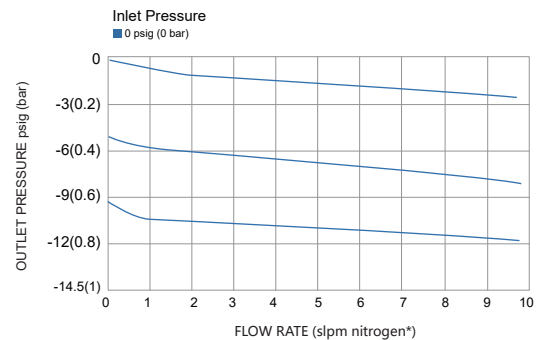
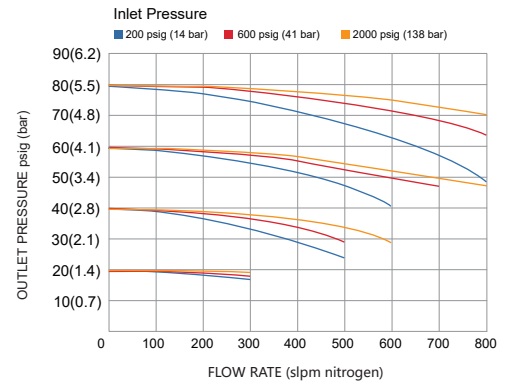
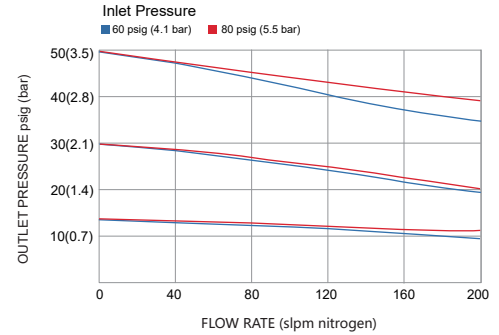

* The volumetric flow rate under normal conditions (0°C, 1 atm) when N₂ gas is flowing.

Single Stage Pressure Regulator VSR-410UB Series

Ordering Information

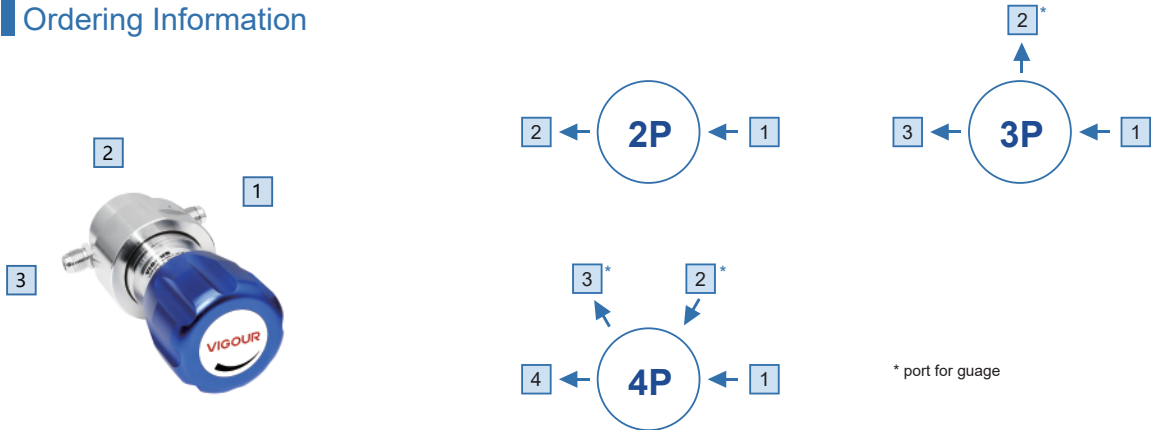

Inlet/Outlet Connection

FV4: 1/4" VFS female
MV4: 1/4" VFS male
FV6: 3/8" VFS female
MV6: 3/8" VFS male

FV8: 1/2" VFS female
MV8: 1/2" VFS male
IFV4: 1/4" (gauge female threaded connection machined on the body)

TW4: 1/4" tube weld
TW6: 3/8" tube weld
TW8: 1/2" tube weld

P: gauge (1/4" VFS fitting)
IP: gauge (IFV4 fitting)

* Other connection standard, consult factory

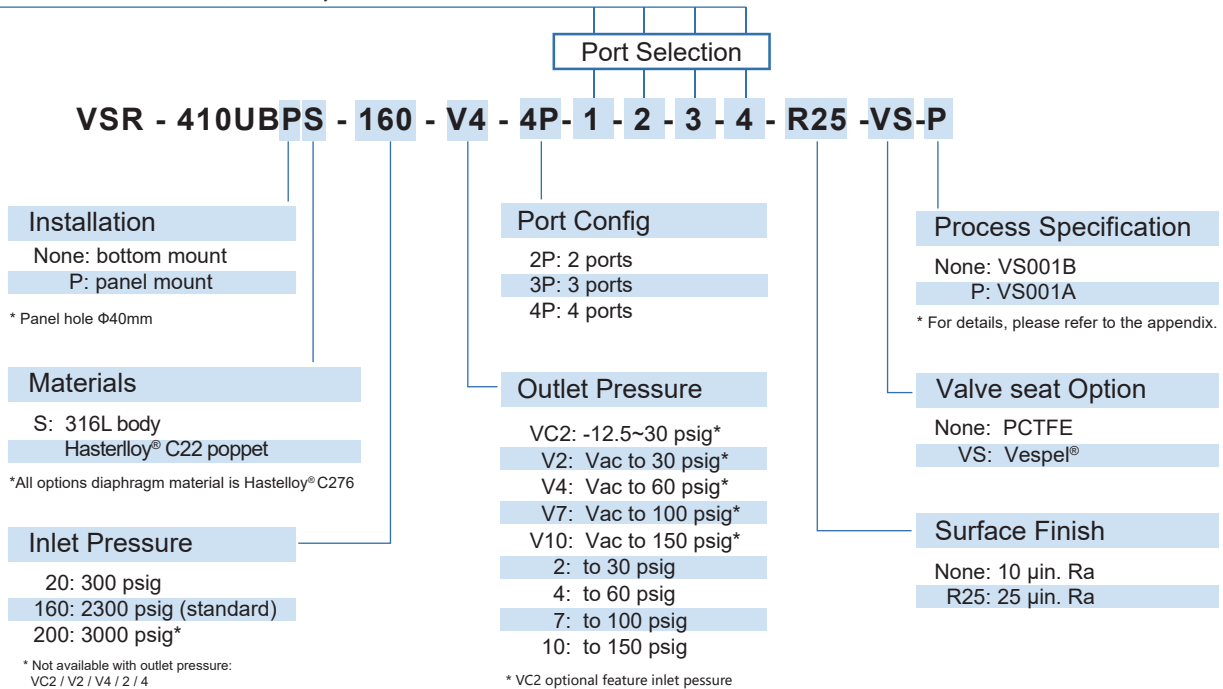

Ordering Example

VSR - 410UBS - 160 - V4 - 2P - MV4 - MV4

1 - 2



Single Stage Pressure Regulator

VSR-410UC Series

Product Feature

- Single-stage pressure regulator
- 10µin Ra average surface finish (10µin. Ra max, 7µin. Ra max. 5µin. Ra max optional)
- Minimized internal volume for short purge times
- All materials used meet ASTM A479 / A484 / A276 standards
- Internal connectors for pressure gauges
- High control accuracy
- Metal-to-metal seal to atmosphere
- Simple outlet pressure limitation by hand-wheel
- 100% helium-leak-tested
- Tied-diaphragm design
- Sub-atmospheric pressure delivery option



Dimensions (mm)

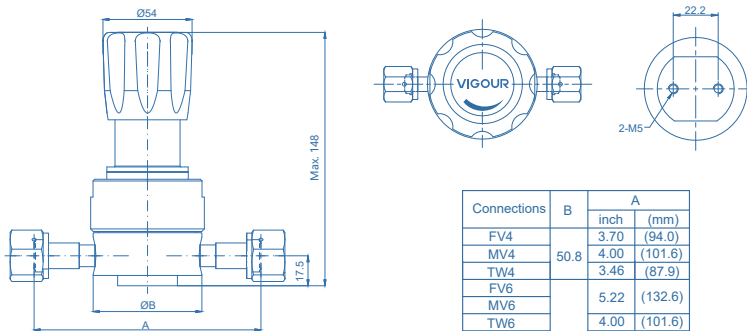

Technical Data

Type:	single-stage
Inlet pressure P ₁ :	Max. 3000 psig (200bar)
Outlet pressure P ₂ :	Vac to 30/30/60/100/150 psig (2/4/7/10bar)
Surface finish:	10µin Ra average surface finish (10µin. Ra max, 7µin. Ra max, 5µin. Ra max optional)
Materials	
Body:	see ordering info
Valve seat:	PCTFE (Vespel® optional)
Diaphragm:	Hastelloy® C276
Inlets and Outlets:	1/4" / 3/8" / 1/2" or 3/4" VFS fitting or tube weld
Bonnet port:	1/8" NPT(F) (on panel mount option, bonnet port is not threaded)
Temperature range:	-40°F to +160°F (-40°C to +71°C)
Leak rate: (to atmosphere)	1x10 ⁻⁹ mbar·l/s He
(via seat)	1x10 ⁻⁸ mbar·l/s He
Flow capacity:	Cv=0.45
Supply pressure effect:	1.6 psig rise in delivery pressure per 100 psig source pressure drop
Weight:	approx. 2.1kg (depending on connections or options)

Flowchart

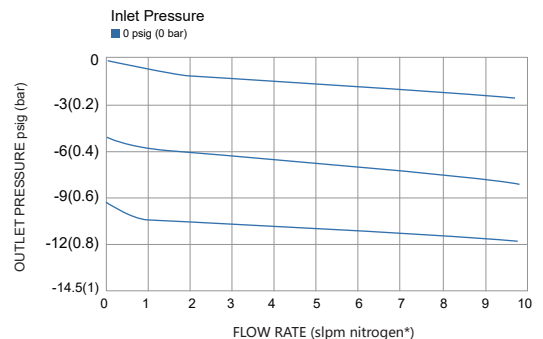
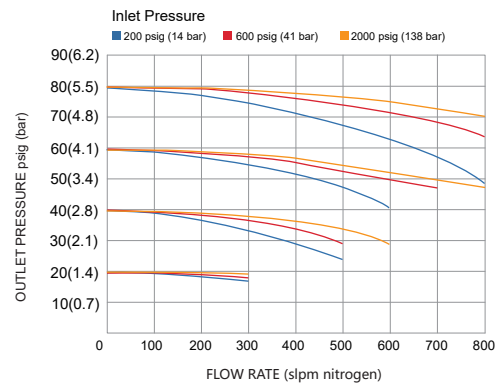
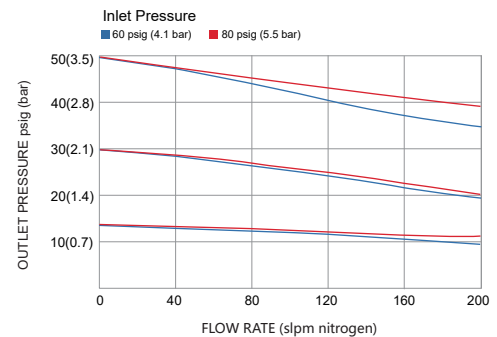

* The volumetric flow rate under normal conditions (0°C, 1 atm) when N₂ gas is flowing.

Single Stage Pressure Regulator VSR-410UC Series

Ordering Information

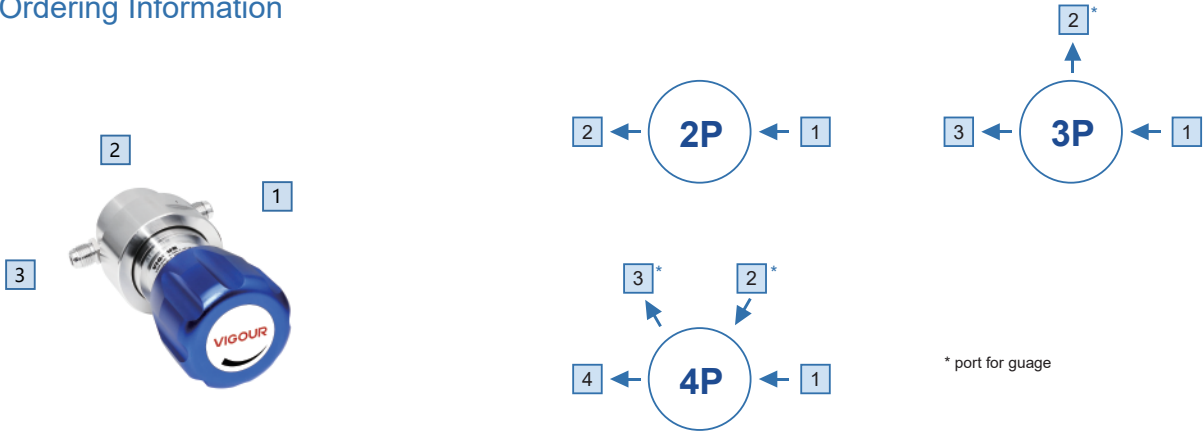

Inlet/outlet Connection

FV4: 1/4" VFS female
MV4: 1/4" VFS male
FV6: 3/8" VFS female
MV6: 3/8" VFS male

FV8: 1/2" VFS female
MV8: 1/2" VFS male
IFV4: 1/4" (gauge female threaded connection machined on the body)

TW4: 1/4" tube weld
TW6: 3/8" tube weld
TW8: 1/2" tube weld

P: gauge (1/4" VFS fitting)
IP: gauge (IFV4 fitting)

* Other connection standard, consult factory

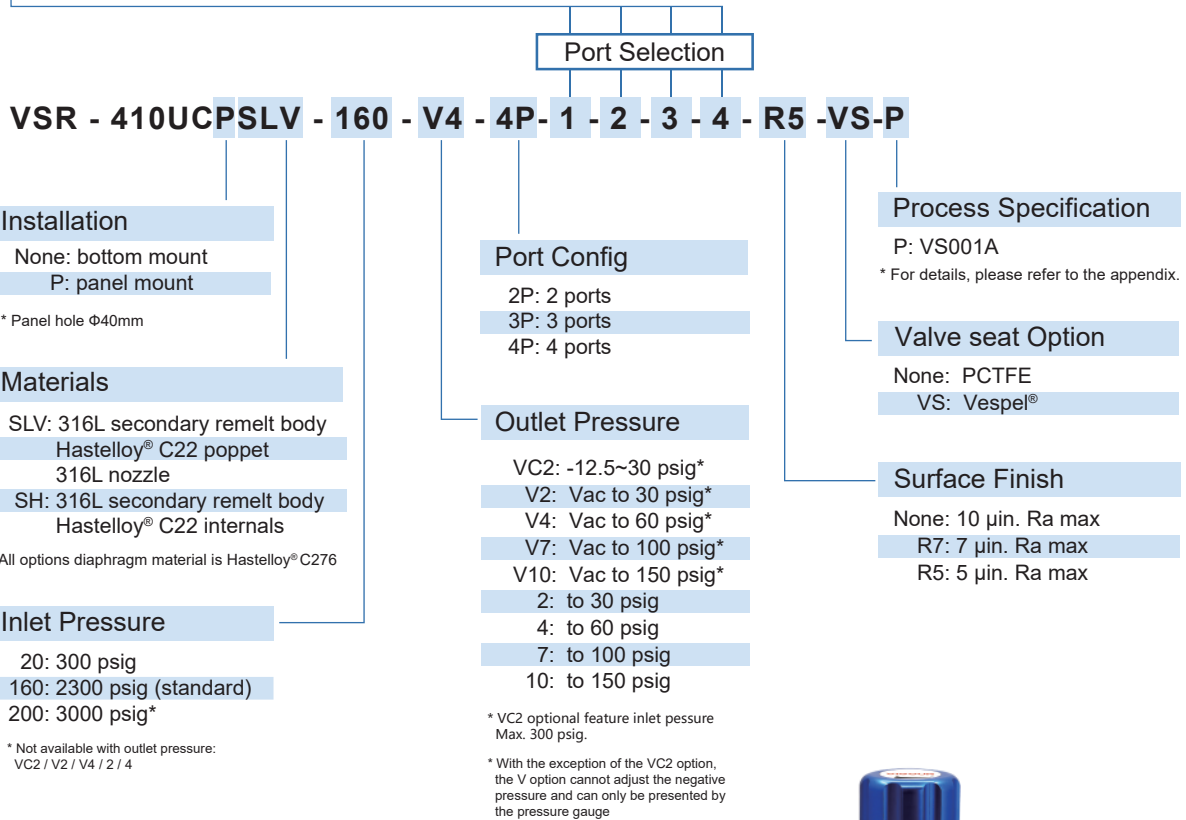

Ordering Example

VSR - 410UCSLV - 160 - V4 - 2P - MV4 - FV4

1 - 2



Single Stage Pressure Regulator

VSR-510UB Series

Product Feature

- Single-stage pressure regulator
- 10µin. Ra surface finish (25µin. Ra optional)
- Minimized internal volume for short purge times
- All materials used meet ASTM A479 / A484 / A276 standards
- Internal connectors for pressure gauges
- Flow capacity: to 30 slpm (standard), to 120 slpm (optional)
- High control accuracy
- Metal-to-metal seal to atmosphere
- Simple outlet pressure limitation by hand-wheel
- 100% helium-leak-tested
- Tied-diaphragm design



Dimensions (mm)

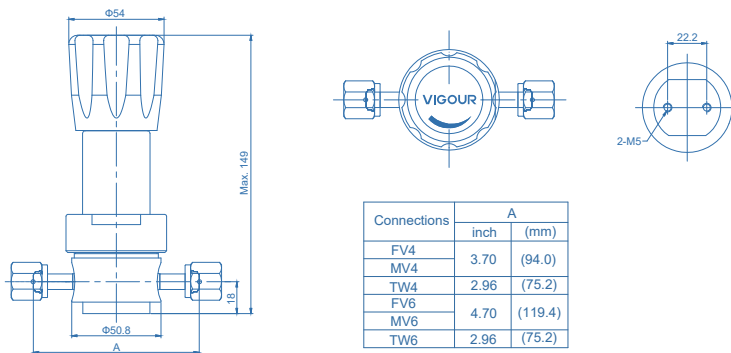

Technical Data

Type:	single-stage
Inlet pressure P1:	Max. 3500 psig (250bar)
Outlet pressure P2:	Vac to 30/60/100/150 psig (2/4/7/10bar)
Surface finish:	10µin. Ra (25µin. Ra optional)
Materials	
Body:	see ordering info
Valve seat:	PCTFE (VespeI® optional)
Diaphragm:	Hastelloy® C276
Inlets and Outlets:	1/4" / 3/8" VFS fitting and tube weld
Bonnet port:	1/8" NPT (on panel mount option, bonnet port is not threaded)
Temperature range:	-40°F to +160°F (-40°C to +71°C)
Leak rate: (to atmosphere)	1x10 ⁻⁹ mbar-l/s He
(via seat)	1x10 ⁻⁸ mbar-l/s He
Flow capacity:	Cv=0.09 (Cv=0.15 optional)
Supply pressure effect:	0.35 psig rise in delivery pressure per 100 psig source pressure drop @Cv=0.09 0.5psig rise in delivery pressure per 100 psig source pressure drop @Cv=0.15
Weight:	approx. 1.35kg (depending on connections or options)

Flowchart

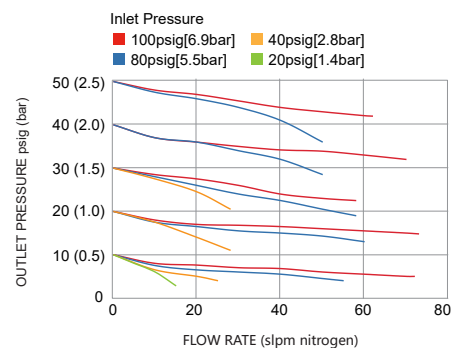
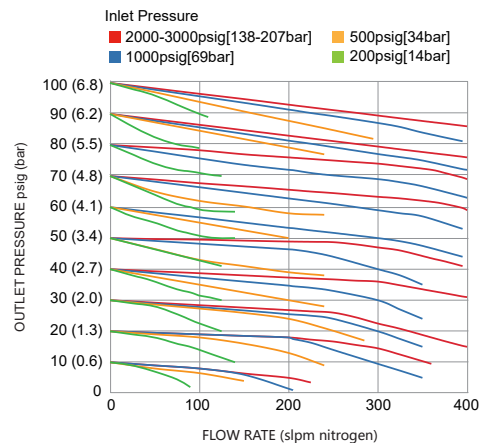

Single Stage Pressure Regulator VSR-510UB Series

Ordering Information

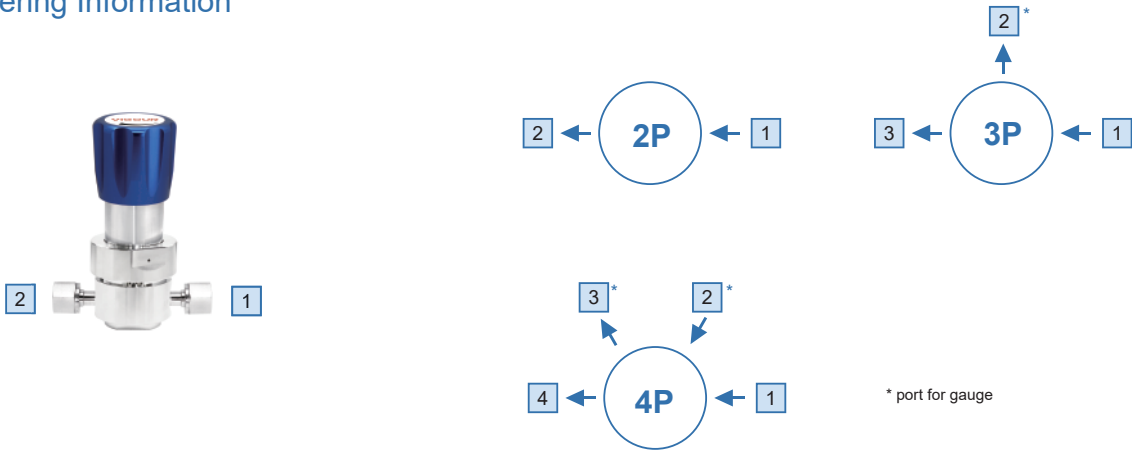

Inlet/outlet Connection

FV4: 1/4" VFS female
MV4: 1/4" VFS male
FV6: 3/8" VFS female
MV6: 3/8" VFS male

IFV4: 1/4" (gauge female threaded connection machined on the body)
TW4: 1/4" tube weld
TW6: 3/8" tube weld

P: gauge (1/4" VFS fitting)
IP: gauge (IFV4 fitting)

* Other connection standard, consult factory

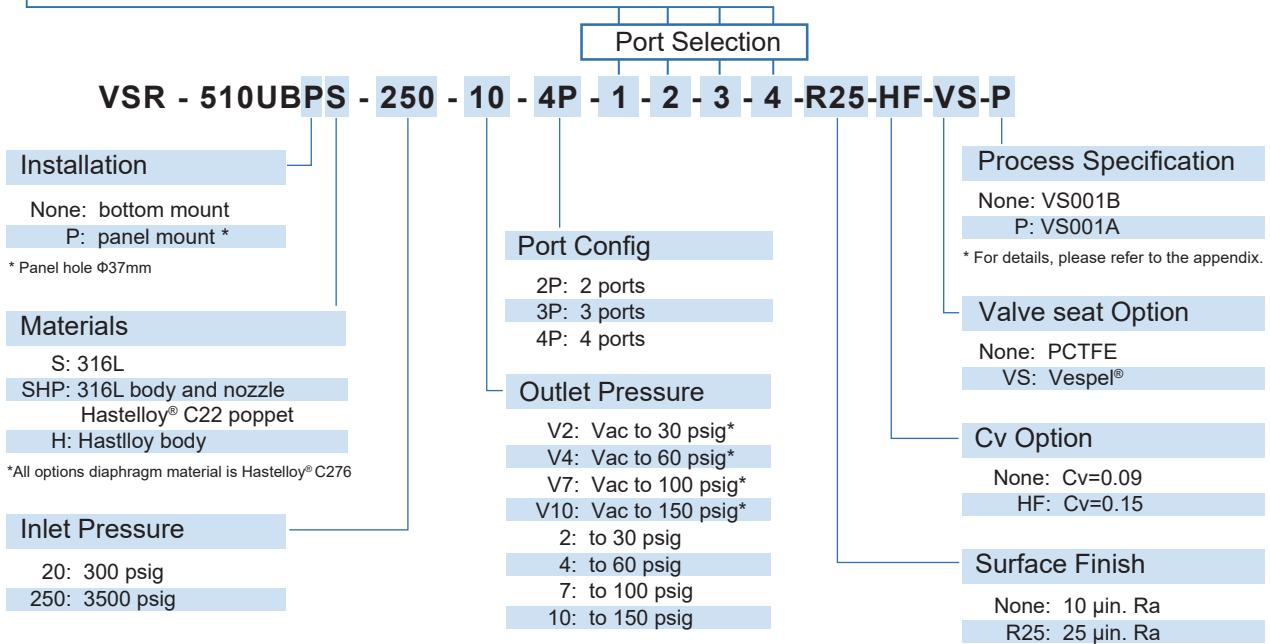

* With the V option, the negative pressure can not be adjusted, only the pressure gauge shows the negative pressure.

Ordering Example

VSR - 510UBS - 250 - 10 - FV4 - P - P - FV4

1 - 2 - 3 - 4



Single Stage Pressure Regulator

VSR-510UC Series

Product Feature

- Single-stage pressure regulator
- 10µin Ra average surface finish (10µin. Ra max, 7µin. Ra max. 5µin. Ra max optional)
- Minimized internal volume for short purge times
- All materials used meet ASTM A479 / A484 / A276 standards
- Internal connectors for pressure gauges
- Flow capacity: to 30 slpm (standard), to 120 slpm (optional)
- High control accuracy
- Metal-to-metal seal to atmosphere
- Simple outlet pressure limitation by hand-wheel
- 100% helium-leak-tested
- Tied-diaphragm design



Dimensions (mm)

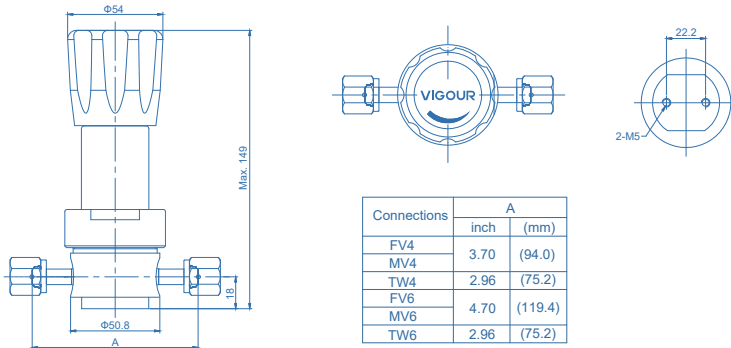

Technical Data

Type:	single-stage
Inlet pressure P1:	Max. 3500 psig (250bar)
Outlet pressure P2:	Vac to 30/60/100/150 psig (2/4/7/10bar)
Surface finish:	10µin Ra average surface finish (10µin. Ra max, 7µin. Ra max, 5µin. Ra max optional)
Materials	
Body:	see ordering info
Valve seat:	PCTFE (Vespel® optional)
Diaphragm:	Hastelloy® C276
Inlets and Outlets:	1/4" / 3/8" VFS fitting and tube weld
Bonnet port:	1/8" NPT (on panel mount option, bonnet port is not threaded)
Temperature range:	-40°F to +160°F (-40°C to +71°C)
Leak rate: (to atmosphere)	1x10 ⁻⁹ mbar·l/s He
(via seat)	1x10 ⁻⁸ mbar·l/s He
Flow capacity:	Cv=0.09 (Cv=0.15 optional)
Supply pressure effect:	0.35 psig rise in delivery pressure per 100 psig source pressure drop @Cv=0.09 0.5psig rise in delivery pressure per 100 psig source pressure drop @Cv=0.15
Weight:	approx. 1.35kg (depending on connections or options)

Flowchart

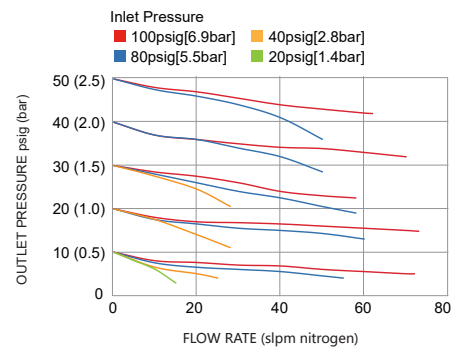
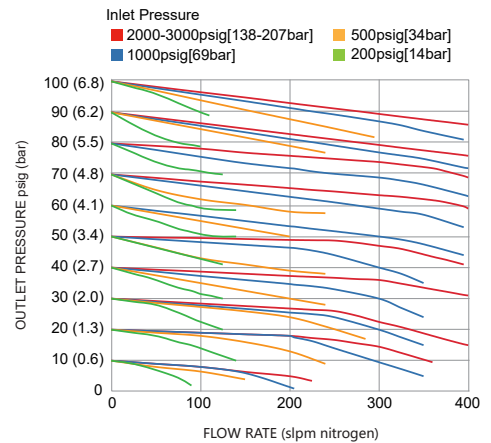

Single Stage Pressure Regulator VSR-510UC Series

Ordering Information

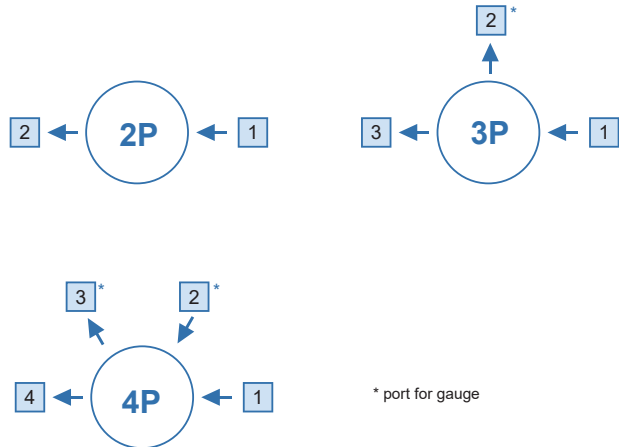

Inlet/outlet Connection

FV4: 1/4" VFS female
MV4: 1/4" VFS male
FV6: 3/8" VFS female
MV6: 3/8" VFS male

IFV4: 1/4" (gauge female threaded connection machined on the body)
TW4: 1/4" tube weld
TW6: 3/8" tube weld

P: gauge (1/4" VFS fitting)
IP: gauge (IFV4 fitting)

* Other connection standard, consult factory

Port Selection

VSR - 510UCPSLV - 250 - 10 - 4P - 1 - 2 - 3 - 4 - R5 - HF - VS - P

Installation

None: bottom mount
P: panel mount *

* Panel hole Φ 37mm

Materials

SLV: 316L secondary remelt body
SHP: 316L secondary remelt body
Hastelloy® C22 poppet
H: Hastloy body

*All options diaphragm material is Hastelloy® C276

Inlet Pressure

20: 300 psig
250: 3500 psig

Port Config

2P: 2 ports
3P: 3 ports
4P: 4 ports

Outlet Pressure

V2: Vac to 30 psig*
V4: Vac to 60 psig*
V7: Vac to 100 psig*
V10: Vac to 150 psig*
2: to 30 psig
4: to 60 psig
7: to 100 psig
10: to 150 psig

* With the V option, the negative pressure can not be adjusted, only the pressure gauge shows the negative pressure.

Process Specification

P: VS001A

* For details, please refer to the appendix.

Valve seat Option

None: PCTFE
VS: Vespel®

Cv Option

None: Cv=0.09
HF: Cv=0.15

Surface Finish

None: 10 μ m. Ra max
R7: 7 μ m. Ra max
R5: 5 μ m. Ra max

Ordering Example

VSR - 510UCSLV - 250 - 10 - FV4 - P - P - FV4

1 - 2 - 3 - 4



Single Stage Pressure Regulator

VSR-610UB Series

Product Feature

- Single-stage pressure regulator
- 10µin. Ra surface finish (25µin. Ra optional)
- Minimized internal volume for short purge times
- All materials used meet ASTM A479 / A484 / A276 standards
- Internal connectors for pressure gauges
- High control accuracy
- Metal-to-metal seal to atmosphere
- Simple outlet pressure limitation by hand-wheel
- 100% helium-leak-tested



Dimensions (mm)

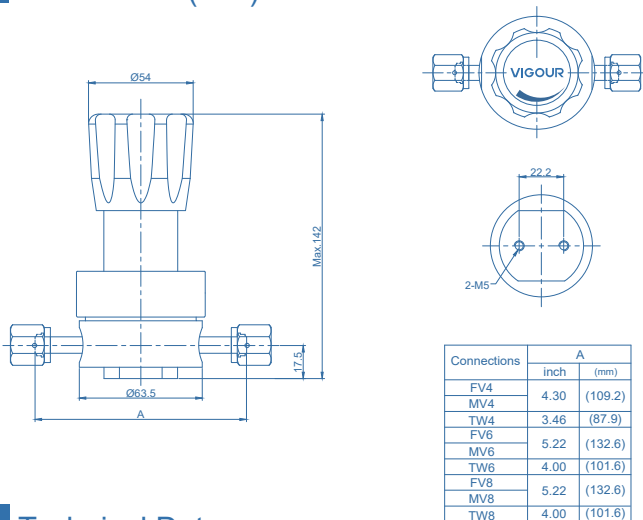

Technical Data

Type:	single-stage
Inlet pressure P1:	Max. 3500 psig (250bar)
Outlet pressure P2:	Vac to 10/30/60/100 psig (1/2/4/7bar)
Surface finish:	10µin. Ra (25µin. Ra optional)
Materials	
Body:	see ordering info
Valve seat:	PCTFE (VespeI® optional)
Diaphragm:	Hastelloy® C276
Inlets and Outlets:	1/4" / 3/8" or 1/2" VFS fitting or tube weld
Bonnet port:	1/8" NPT (on panel mount option, bonnet port is not threaded)
Temperature range:	-40°F to +160°F (-40°C to +71°C)
Leak rate: (to atmosphere)	1x10 ⁻⁹ mbar·l/s He
(via seat)	1x10 ⁻⁸ mbar·l/s He
Flow capacity:	Cv=0.13
Supply pressure effect:	0.25 psig rise in delivery pressure per 100 psig source pressure drop
Weight:	approx. 1.54kg (depending on connections or options)

Flowchart

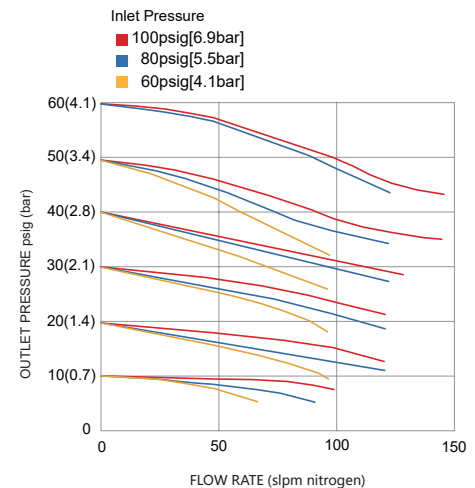
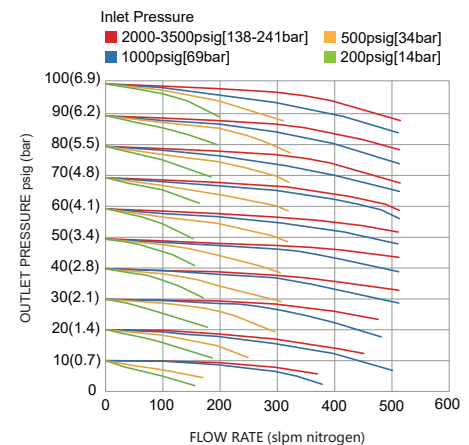

Single Stage Pressure Regulator VSR-610UB Series

Ordering Information

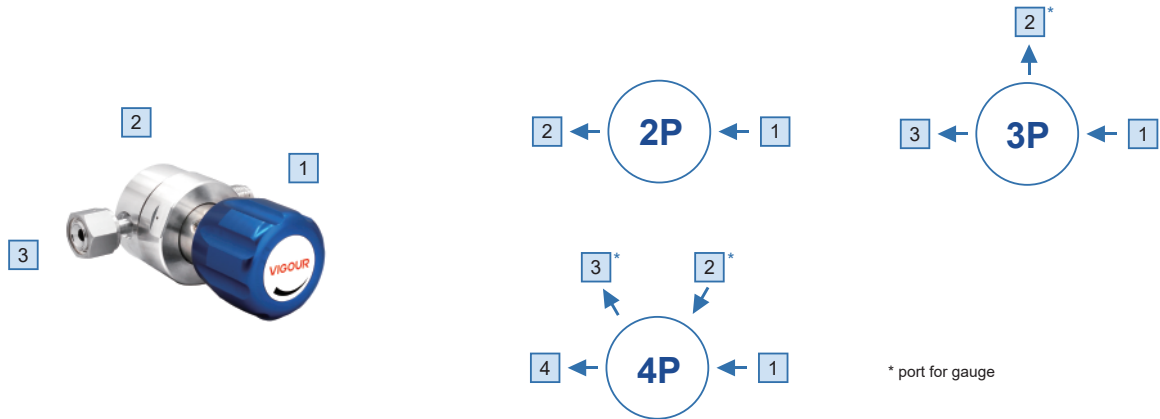

Inlet/outlet Connection

FV4: 1/4" VFS female	FV8: 1/2" VFS female	TW4: 1/4" tube weld	P: gauge (1/4" VFS fitting)
MV4: 1/4" VFS male	MV8: 1/2" VFS male	TW6: 3/8" tube weld	IP: gauge (IFV4 fitting)
FV6: 3/8" VFS female	IFV4: 1/4" (gauge female threaded connection machined on the body)	TW8: 1/2" tube weld	
MV6: 3/8" VFS male			

* Other connection standard, consult factory

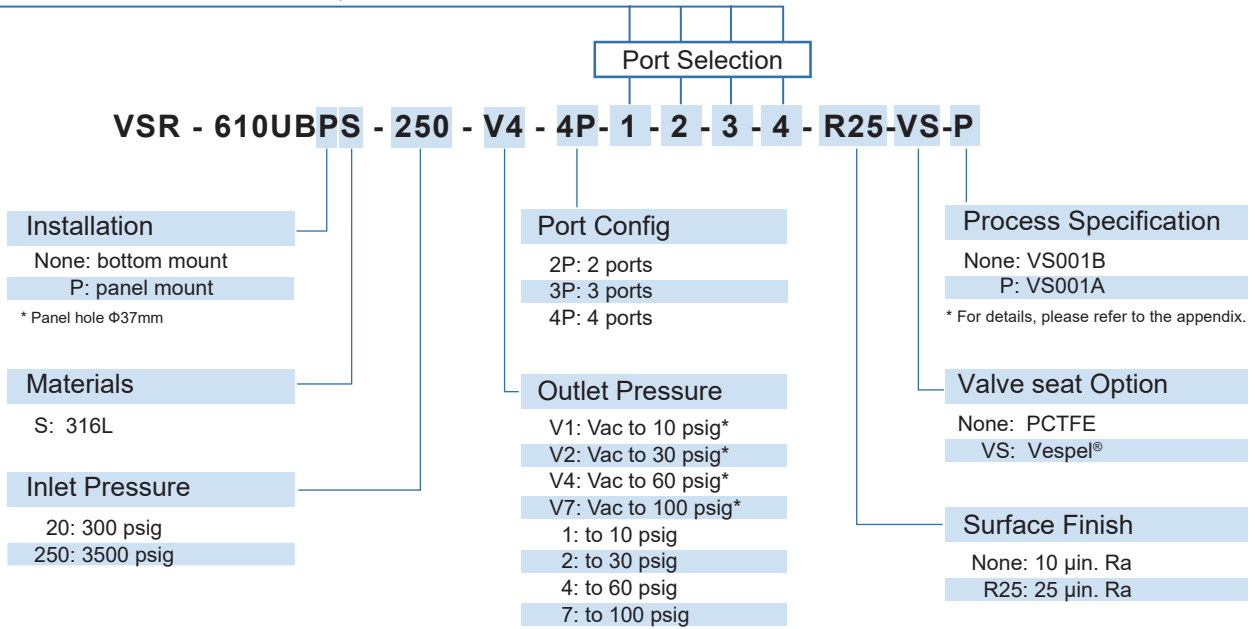

* With the V option, the negative pressure can not be adjusted, only the pressure gauge shows the negative pressure.

Ordering Example

VSR - 610UBS - 250 - V4 - 2P - MV4 - FV4

1 - 2



Single Stage Pressure Regulator

VSR-610UC Series

Product Feature

- Single-stage pressure regulator
- 10µin Ra average surface finish (10µin. Ra max, 7µin. Ra max, 5µin. Ra max optional)
- Minimized internal volume for short purge times
- All materials used meet ASTM A479 / A484 / A276 standards
- Internal connectors for pressure gauges
- High control accuracy
- Metal-to-metal seal to atmosphere
- Simple outlet pressure limitation by hand-wheel
- 100% helium-leak-tested



Dimensions (mm)

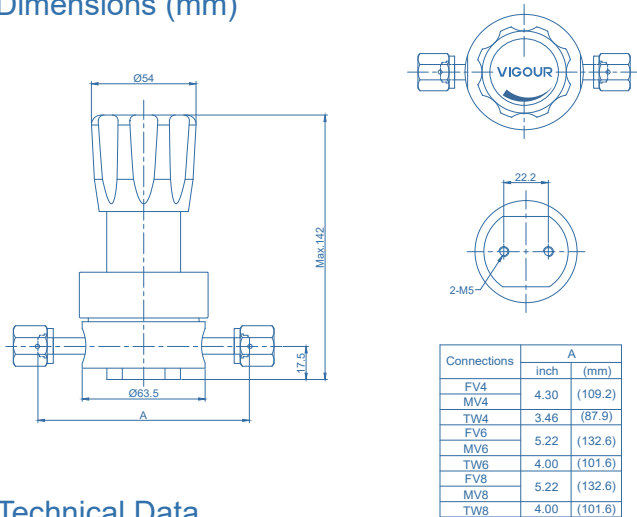

Technical Data

Type:	single-stage
Inlet pressure P1:	Max.. 3500 psig (250bar)
Outlet pressure P2:	Vac to 10/30/60/100 psig (1/2/4/7bar)
Surface finish:	10µin Ra average surface finish (10µin. Ra max, 7µin. Ra max, 5µin. Ra max optional)
Materials	
Body:	see ordering info
Valve seat:	PCTFE (Vespel® optional)
Diaphragm:	Hastelloy® C276
Inlets and Outlets:	1/4" / 3/8" or 1/2" VFS fitting or tube weld
Bonnet port:	1/8" NPT (on panel mount option, bonnet port is not threaded)
Temperature range:	-40°F to +160°F (-40°C to +71°C)
Leak rate: (to atmosphere)	1x10 ⁻⁹ mbar·l/s He
(via seat)	1x10 ⁻⁸ mbar·l/s He
Flow capacity:	Cv=0.13
Supply pressure effect:	0.25 psig rise in delivery pressure per 100 psig source pressure drop
Weight:	approx. 1.54kg (depending on connections or options)

Flowchart

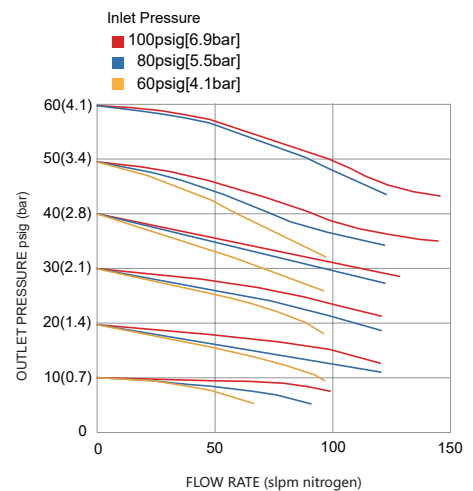
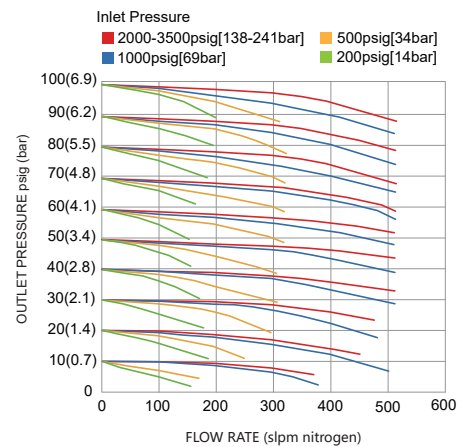

Single Stage Pressure Regulator VSR-610UC Series

Ordering Information

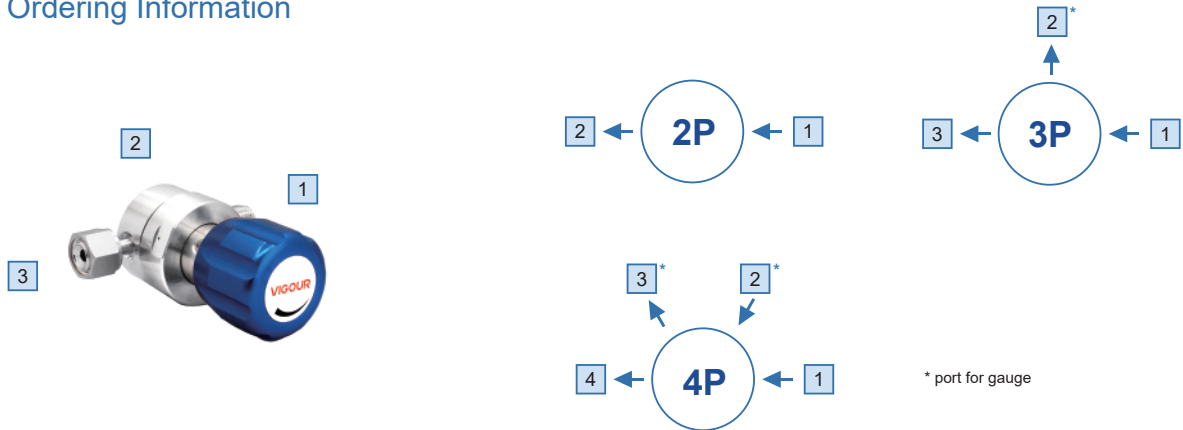

Inlet/outlet Connection

FV4: 1/4" VFS female
MV4: 1/4" VFS male
FV6: 3/8" VFS female
MV6: 3/8" VFS male

FV8: 1/2" VFS female
MV8: 1/2" VFS male
IFV4: 1/4" (gauge female threaded connection machined on the body)

TW4: 1/4" tube weld
TW6: 3/8" tube weld
TW8: 1/2" tube weld

P: gauge (1/4" VFS fitting)
IP: gauge (IFV4 fitting)

* Other connection standard, consult factory

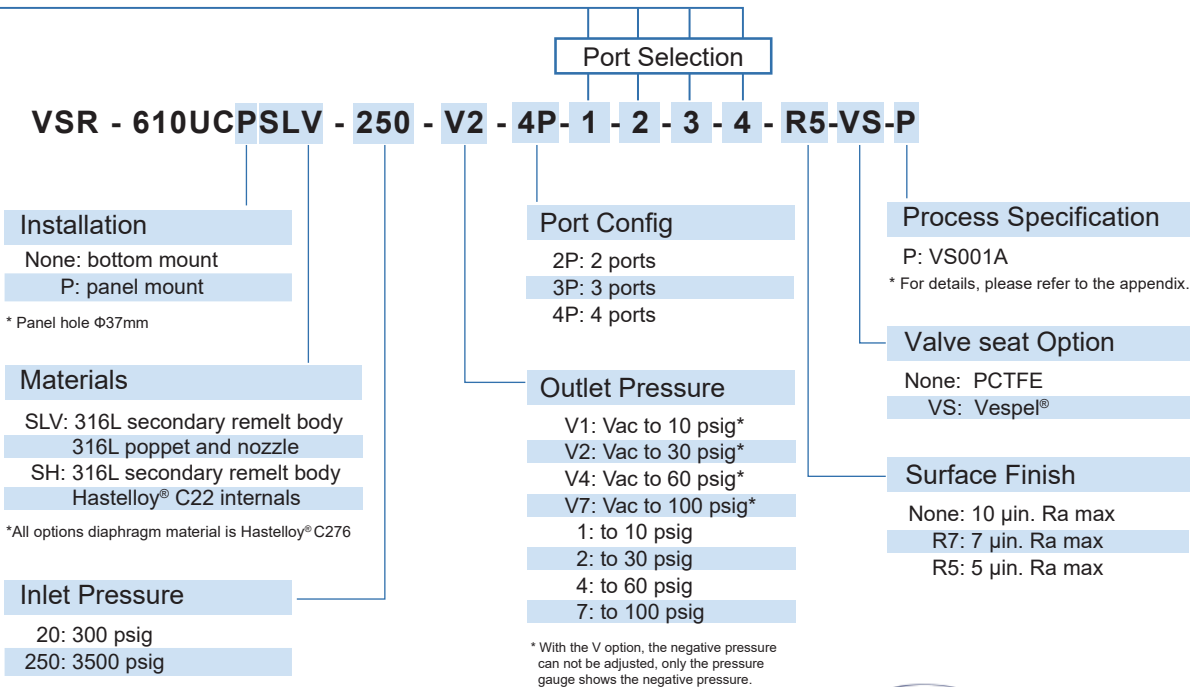

Ordering Example

VSR - 610UCSLV - 250 - V4 - 2P - MV4 - FV4

1 - 2



Dual Stage Pressure Regulator

VSR-710UB Series

Product Feature

- Dual-stage pressure regulator
- 10µin. Ra surface finish (25µin. Ra optional)
- Minimized internal volume for short purge times
- All materials used meet ASTM A479 / A484 / A276 standards
- Internal connectors for pressure gauges
- Flow capacity: to 30 slpm (standard), to 120 slpm (optional)
- High control accuracy
- Metal-to-metal seal to atmosphere
- Simple outlet pressure limitation by hand-wheel
- 100% helium-leak-tested
- Tied-diaphragm design



Dimensions (mm)

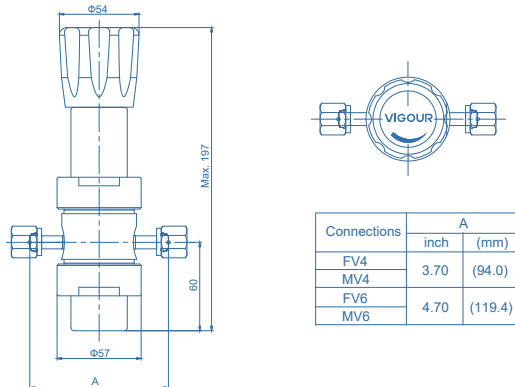

Technical Data

Type:	Dual-stage
Inlet pressure P1:	3500 psig (250bar)
Outlet pressure P2:	Vac to 30/60/100 psig (2/4/7bar)
Surface finish:	10µin. Ra (25µin. Ra optional)
Materials	
Body:	see ordering info
Valve seat:	PCTFE (VespeI® optional)
Diaphragm:	Hastelloy® C276
Inlets and Outlets:	1/4" / 3/8" VFS fitting and tube weld
Bonnet port:	1/8" NPT (on panel mount option, bonnet port is not threaded)
Temperature range:	-40°F to +160°F (-40°C to +71°C)
Leak rate: (to atmosphere)	1x10 ⁻⁹ mbar·l/s He
(via seat)	1x10 ⁻⁸ mbar·l/s He
Flow capacity:	Cv=0.05
Supply pressure effect:	0.05 psig rise in delivery pressure per 100 psig source pressure drop
Weight:	approx. 2.5kg (depending on connections or options)

Flowchart

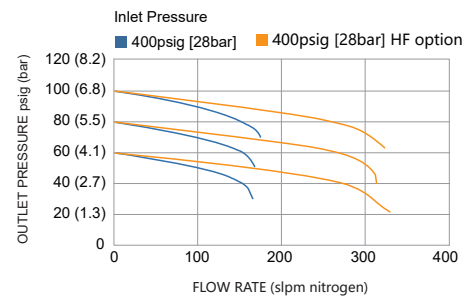
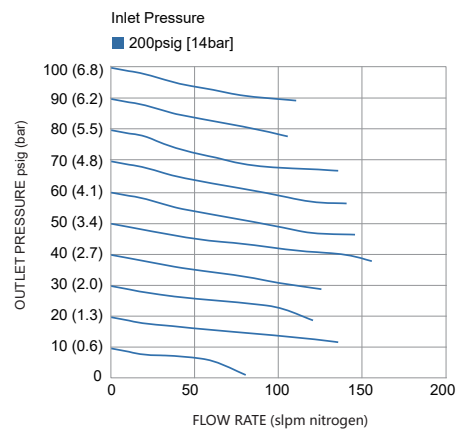

Dual Stage Pressure Regulator VSR-710UB Series

Ordering Information

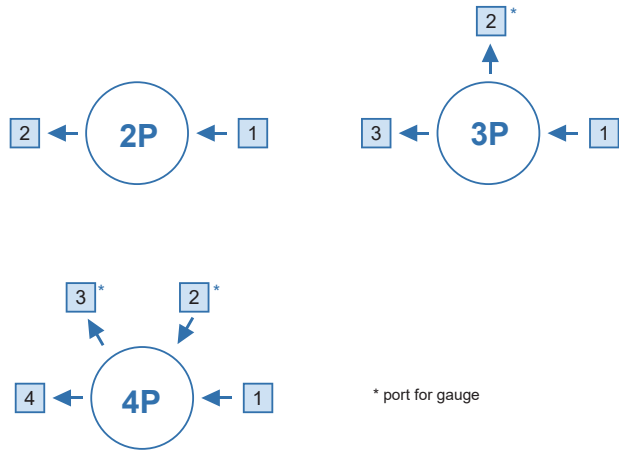

* port for gauge

Inlet/outlet Connection

FV4: 1/4" VFS female
MV4: 1/4" VFS male
FV6: 3/8" VFS female
MV6: 3/8" VFS male

IFV4: 1/4" (gauge female threaded connection machined on the body)
TW4: 1/4" tube weld
TW6: 3/8" tube weld

P: gauge (1/4" VFS fitting)
IP: gauge (IFV4 fitting)

* Other connection standard, consult factory

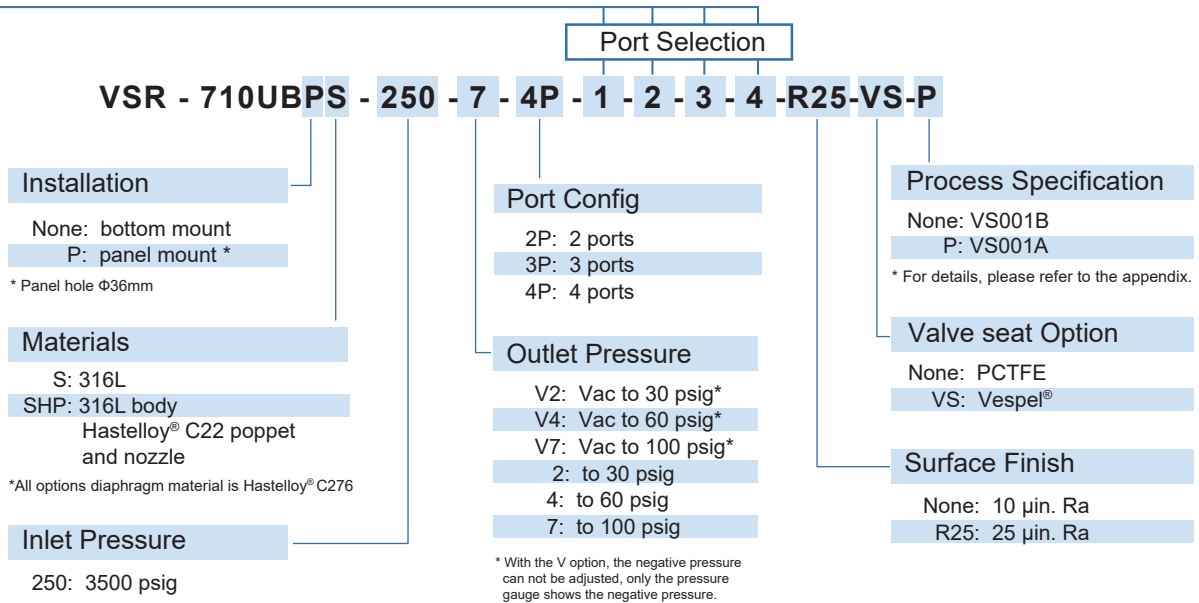

Ordering Example

VSR - 710UBS - 250 - 7 - FV4 - P - P - FV4

1 - 2 - 3 - 4



Dual Stage Pressure Regulator

VSR-710UC Series

Product Feature

- Dual-stage pressure regulator
- 10µin Ra average surface finish
(10µin. Ra max, 7µin. Ra max. 5µin. Ra max optional)
- Minimized internal volume for short purge times
- All materials used meet ASTM A479 / A484 / A276 standards
- Internal connectors for pressure gauges
- Flow capacity: to 30 slpm (standard), to 120 slpm (optional)
- High control accuracy
- Metal-to-metal seal to atmosphere
- Simple outlet pressure limitation by hand-wheel
- 100% helium-leak-tested
- Tied-diaphragm design



Dimensions (mm)

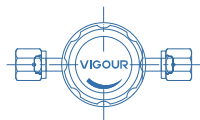
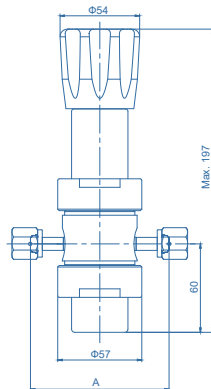

Connections	A	
	inch	(mm)
FV4	3.70	(94.0)
MV4	4.70	(119.4)

Technical Data

Type:	Dual-stage
Inlet pressure P1:	3500 psig (250bar)
Outlet pressure P2:	Vac to 30/60/100 psig (2/4/7bar)
Surface finish:	10µin Ra average surface finish (10µin. Ra max, 7µin. Ra max, 5µin. Ra max optional)
Materials	
Body:	see ordering info
Valve seat:	PCTFE (Vespe ^l ® optional)
Diaphragm:	Hastelloy [®] C276
Inlets and Outlets:	1/4" / 3/8" VFS fitting and tube weld
Bonnet port:	1/8" NPT (on panel mount option, bonnet port is not threaded)
Temperature range:	-40°F to +160°F (-40°C to +71°C)
Leak rate: (to atmosphere)	1x10 ⁻⁹ mbar·l/s He
(via seat)	1x10 ⁻⁸ mbar·l/s He
Flow capacity:	Cv=0.05
Supply pressure effect:	0.05 psig rise in delivery pressure per 100 psig source pressure drop
Weight:	approx. 2.5kg (depending on connections or options)

Flowchart

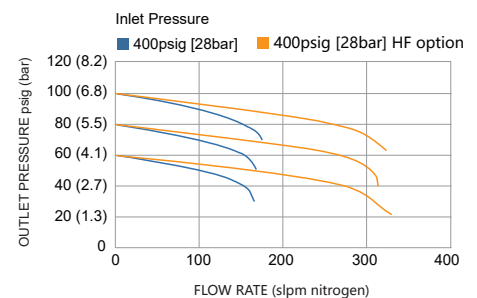
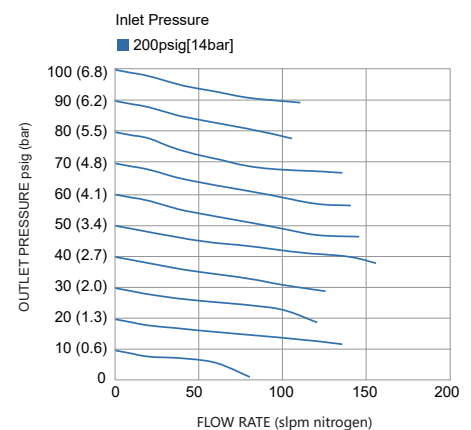

Dual Stage Pressure Regulator VSR-710UC Series

Ordering Information

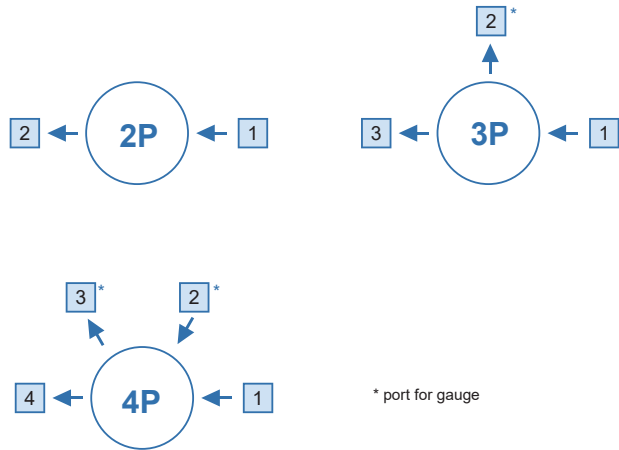

* port for gauge

Inlet/outlet Connection

FV4: 1/4" VFS female
MV4: 1/4" VFS male
FV6: 3/8" VFS female
MV6: 3/8" VFS male

IFV4: 1/4" (gauge female threaded connection machined on the body)
TW4: 1/4" tube weld
TW6: 3/8" tube weld

P: gauge (1/4" VFS fitting)
IP: gauge (IFV4 fitting)

* Other connection standard, consult factory

Port Selection

VSR - 710UCPSLV - 250 - 7 - 4P - 1 - 2 - 3 - 4 - R5-VS-P

Installation

None: bottom mount
P: panel mount *

* Panel hole Φ 36mm

Materials

SLV: 316L secondary remelt body
SHP: 316L body
Hastelloy® C22 poppet
and nozzle

*All options diaphragm material is Hastelloy® C276

Inlet Pressure

250: 3500 psig

Port Config

2P: 2 ports
3P: 3 ports
4P: 4 ports

Outlet Pressure

V2: Vac to 30 psig*
V4: Vac to 60 psig*
V7: Vac to 100 psig*
2: to 30 psig
4: to 60 psig
7: to 100 psig

* With the V option, the negative pressure can not be adjusted, only the pressure gauge shows the negative pressure.

Process Specification

P: VS001A

* For details, please refer to the appendix.

Valve seat Option

None: PCTFE
VS: Vespel®

Surface Finish

None: 10 μ m. Ra max
R7: 7 μ m. Ra max
R5: 5 μ m. Ra max

Ordering Example

VSR - 710UCSLV - 250 - 7 - FV4 - P - P - FV4

1 - 2 - 3 - 4



Single Stage Pressure Regulator

VSR-910UB Series

Product Feature

- Single-stage pressure regulator
- All materials used meet ASTM A479 / A484 / A276 standards
- 15µin. Ra max. 10µin Ra max optional
- design for bulk special gas supply system
- Tied-diaphragm design with bellows sensing element
- Metal-to-metal seal to atmosphere
- 100% helium-leak-tested

Dimensions (mm)

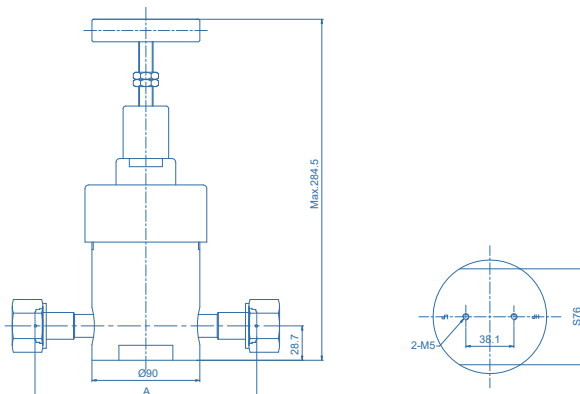

Connections	A	
	inch	(mm)
FV8	6.22	(158.0)
MV8	6.22	(158.0)
TW8	9.50	(241.4)
FV12	7.28	(185.0)
MV12	7.28	(185.0)
TW12	9.50	(241.4)
FV16	7.84	(199.2)
MV16	7.84	(199.2)
TW16	9.50	(241.4)

Technical Data

Type:	single-stage
Inlet pressure P1:	Max. 3000 psig (200bar)
Outlet pressure P2:	Vac to 30/60/100/150 psig (2/4/7/10bar)
Surface finish:	15µin. Ra max 10µin. Ra max (optional)
Materials	
Body:	SS 316L
Valve seat:	PCTFE (Vespel® optional)
Diaphragm:	Hastelloy® C22
Inlets and Outlets:	1/2" / 3/4" or 1" VFS fitting or tube weld
Bonnet port:	1/8" FNPT(optional)
Temperature range:	-40°F to +160°F (-40°C to +71°C)
Leak rate: (to atmosphere)	1x10 ⁻⁹ mbar·l/s He
(via seat)	1x10 ⁻⁸ mbar·l/s He
Flow capacity:	Cv=3.0 / Cv=4.0
Weight:	approx. 6.7kg (depending on connections or options)

Flowchart

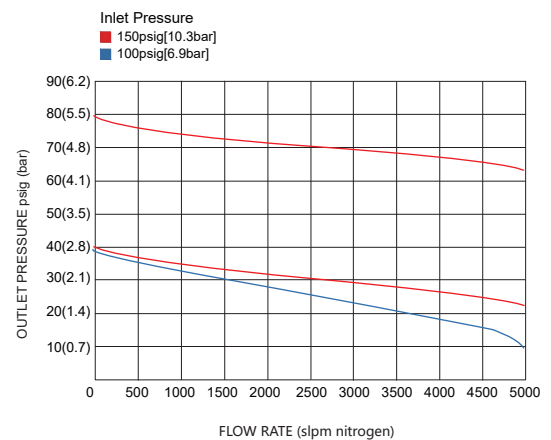

Single Stage Pressure Regulator VSR-910UB Series

Ordering Information

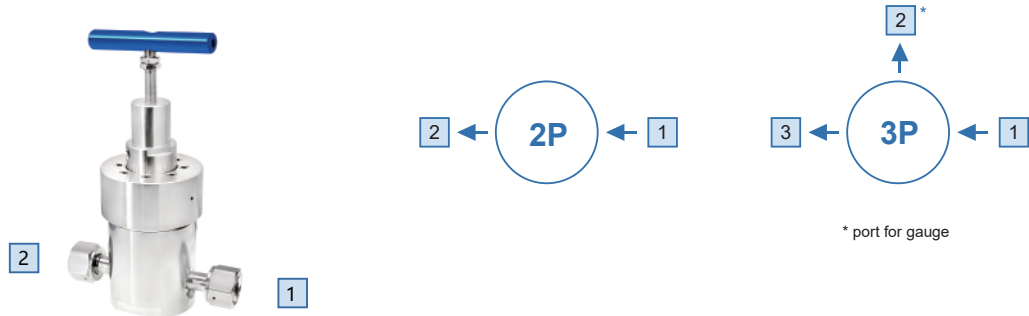

Inlet/Outlet Connection

FV8: 1/2" VFS female
MV8: 1/2" VFS male
FV12: 3/4" VFS female
MV12: 3/4" VFS male

FV16: 1" VFS female
MV16: 1" VFS male
MV4: 1/4" VFS male
IFV4: 1/4" (gauge female threaded connection machined on the body)

TW8: 1/2" tube weld
TW12: 3/4" tube weld
TW16: 1" tube weld

P: gauge (1/4" VFS fitting)
IP: gauge (IFV4 fitting)

* Other connection standard, consult factory

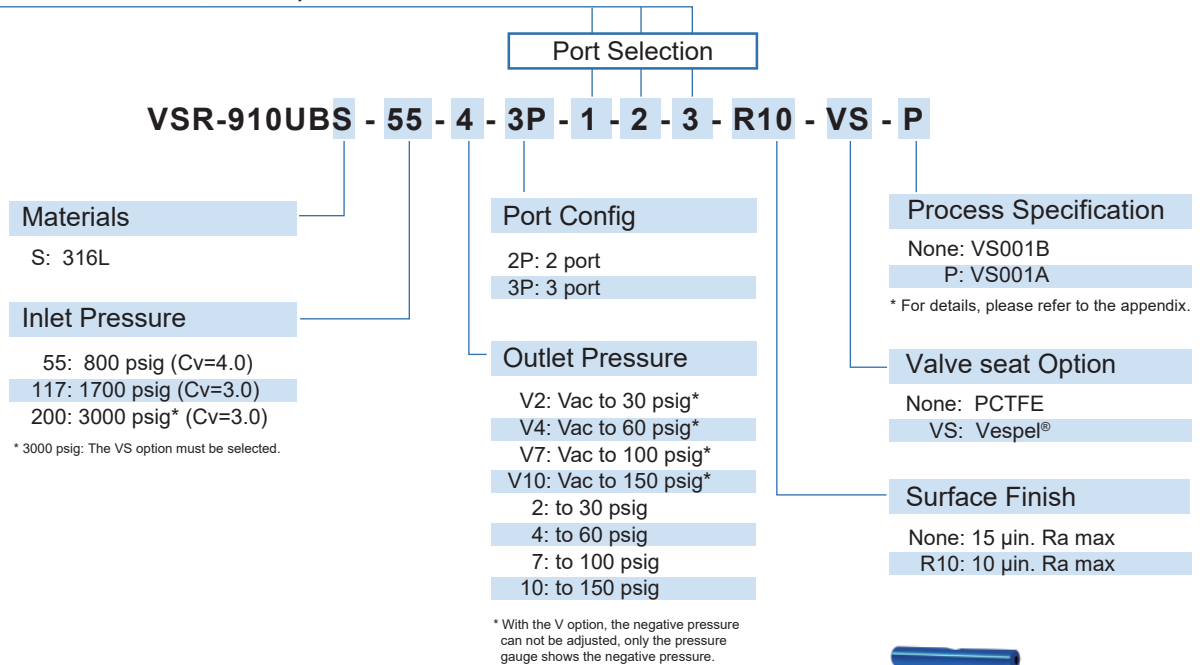

Ordering Example

VSR - 910UBS - 55 - 10 - 2P - MV12 - FV12

1 - 2



Single Stage Pressure Regulator

VSR-911UB Series

Product Feature

- Single-stage pressure regulator
- All materials used meet ASTM A479 / A484 / A276 standards
- 15µin. Ra max. 10µin Ra max optional
- design for bulk special gas supply system
- Tied-diaphragm design with bellows sensing element
- Metal-to-metal seal to atmosphere
- 100% helium-leak-tested

Dimensions (mm)

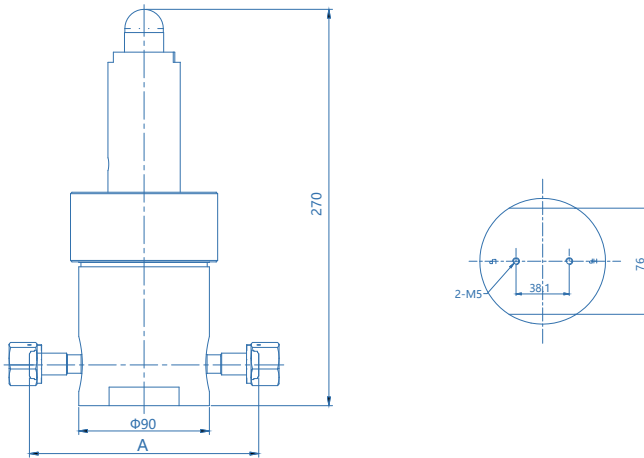

Connections	A	
	inch	(mm)
FV8	6.22	(158.0)
MV8	6.22	(158.0)
TW8	9.50	(241.4)
FV12	7.28	(185.0)
MV12	7.28	(185.0)
TW12	9.50	(241.4)
FV16	7.84	(199.2)
MV16	7.84	(199.2)
TW16	9.50	(241.4)

Technical Data

Type:	single-stage
Inlet pressure P1:	Max. 3000 psig (200bar)
Outlet pressure P2:	300 psig (21bar)
Surface finish:	15µin. Ra max 10µin. Ra max (optional)
Materials	
Body:	SS 316L
Valve seat:	PCTFE (Vespel® optional)
Diaphragm:	Hastelloy® C22
Inlets and Outlets:	1/2" / 3/4" or 1" face seal or tube weld
Bonnet port:	1/8" FNPT(option)
Temperature range:	-40°F to +160°F (-40°C to +71°C)
Leak rate: (to atmosphere)	1x10 ⁻⁹ mbar·l/s He
(via seat)	1x10 ⁻⁹ mbar·l/s He
Flow capacity:	Cv=3.0 / Cv=4.0
Weight:	approx. 6.0kg (depending on connections or options)

Flowchart

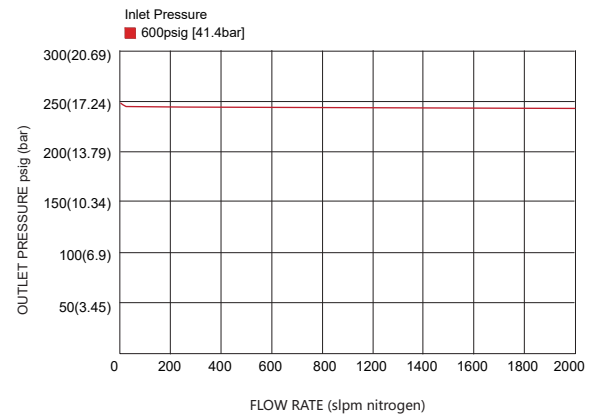

Single Stage Pressure Regulator VSR-911UB Series

Ordering Information

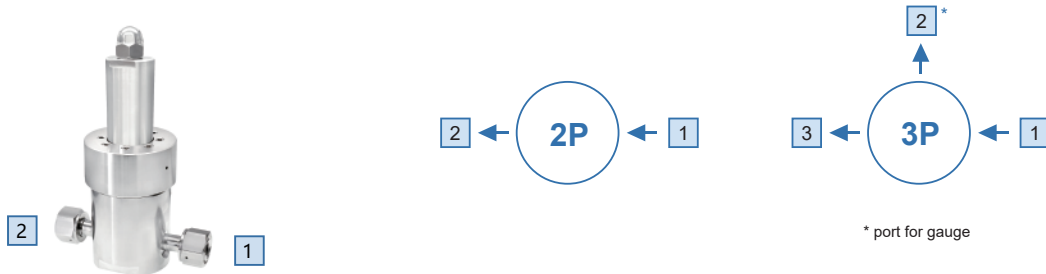

Inlet/Outlet Connection

FV8: 1/2" VFS female
MV8: 1/2" VFS male
FV12: 3/4" VFS female
MV12: 3/4" VFS male

FV16: 1" VFS female
MV16: 1" VFS male
MV4: 1/4" VFS male
IFV4: 1/4" (gauge female threaded connection machined on the body)

TW8: 1/2" tube weld
TW12: 3/4" tube weld
TW16: 1" tube weld

P: gauge (1/4" VFS fitting)
IP: gauge (IFV4 fitting)

* Other connection standard, consult factory

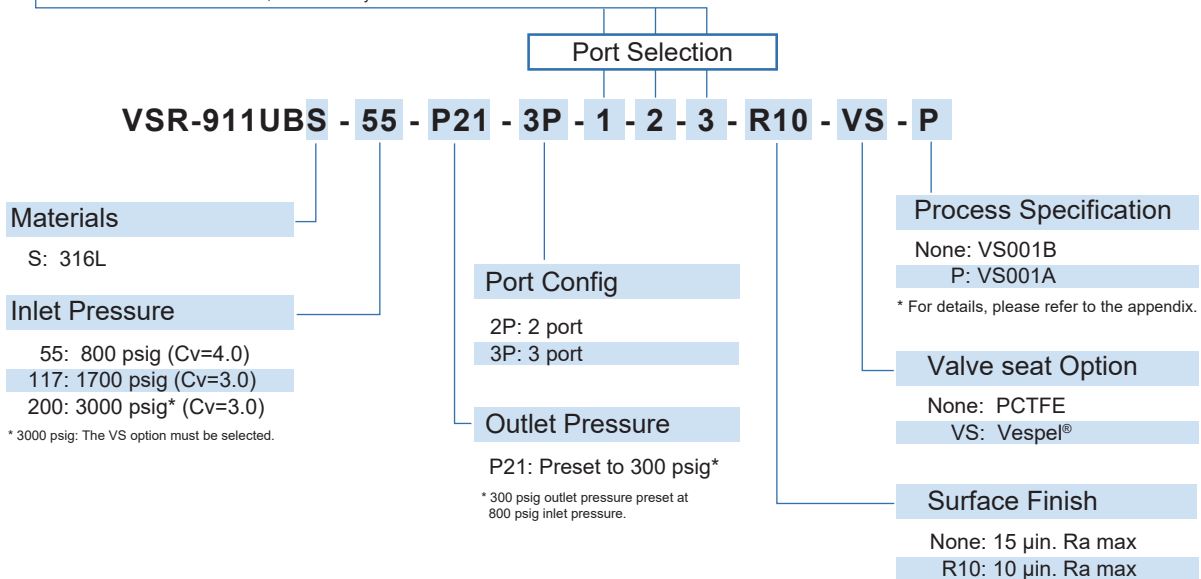

Ordering Example

VSR - 911UBS - 55 - P21 - 2P - MV12 - FV12

1 - 2



Single Stage Pressure Regulator

VSR-920UB Series

Product Feature

- Single-stage pressure regulator
- 10µin. Ra surface finish
- Minimized internal volume for short purge times
- All materials used meet ASTM A479 / A484 / A276 standards
- Internal connectors for pressure gauges
- Flow capacity: to 2000 slpm
- High control accuracy
- Metal-to-metal seal to atmosphere
- Simple outlet pressure limitation by hand-wheel
- 100% helium-leak-tested
- Tied-diaphragm design



Dimensions (mm)

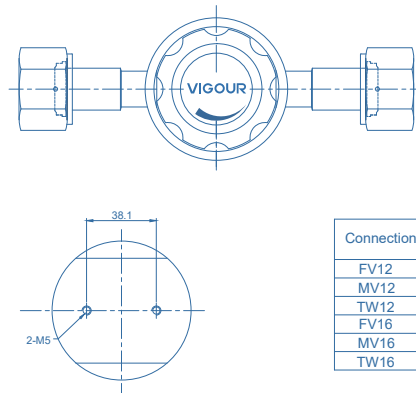
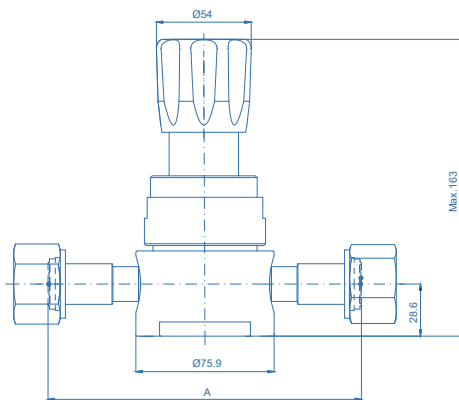

Connections	A	
	inch	(mm)
FV12	6.78	(172.2)
MV12	6.00	(152.4)
TW12	6.00	(152.4)
FV16	7.34	(186.4)
MV16	6.00	(152.4)
TW16	6.00	(152.4)

Technical Data

Type:	single-stage
Inlet pressure P1:	300 psig (20bar)
Outlet pressure P2:	Vac to 30/60/100/150 psig (2/4/7/10bar)
Surface finish:	10µin. Ra
Materials	
Body:	see ordering info
Valve seat:	PFA (VespeI® optional)
Diaphragm:	Hastelloy® C276
Inlets and Outlets:	3/4" / 1" VFS fitting or tube weld
Bonnet port:	1/8" FNPT(option)
Temperature range:	-40°F to +160°F (-40°C to +71°C)
Leak rate: (to atmosphere)	1x10 ⁻⁹ mbar-l/s He
(via seat)	1x10 ⁻⁸ mbar-l/s He
Flow capacity:	Cv=1.6
Weight:	approx. 2.7kg (depending on connections or options)
Supply pressure effect:	7 psig rise in delivery pressure per 100 psig source pressure drop

Flowchart

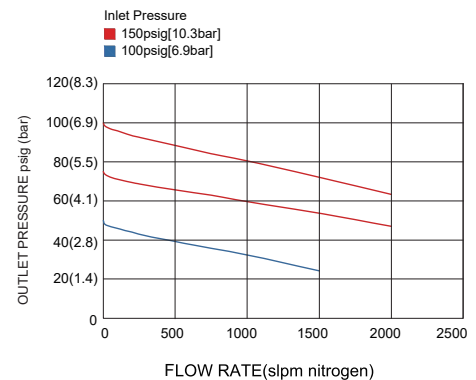

Single Stage Pressure Regulator VSR-920UB Series

Ordering Information

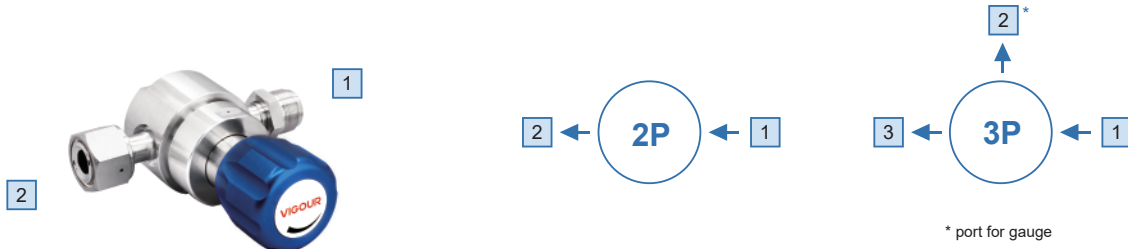

Inlet/Outlet Connection

FV12: 3/4" VFS female
MV12: 3/4" VFS male
FV16: 1" VFS female
MV16: 1" VFS male

FV4: 1/4" VFS female
MV4: 1/4" VFS male
IFV4: 1/4" (gauge female threaded connection machined on the body)

TW12: 3/4" tube weld
TW16: 1" tube weld
P: gauge (1/4" VFS fitting)
IP: gauge (IFV4 fitting)

* Other connection standard, consult factory

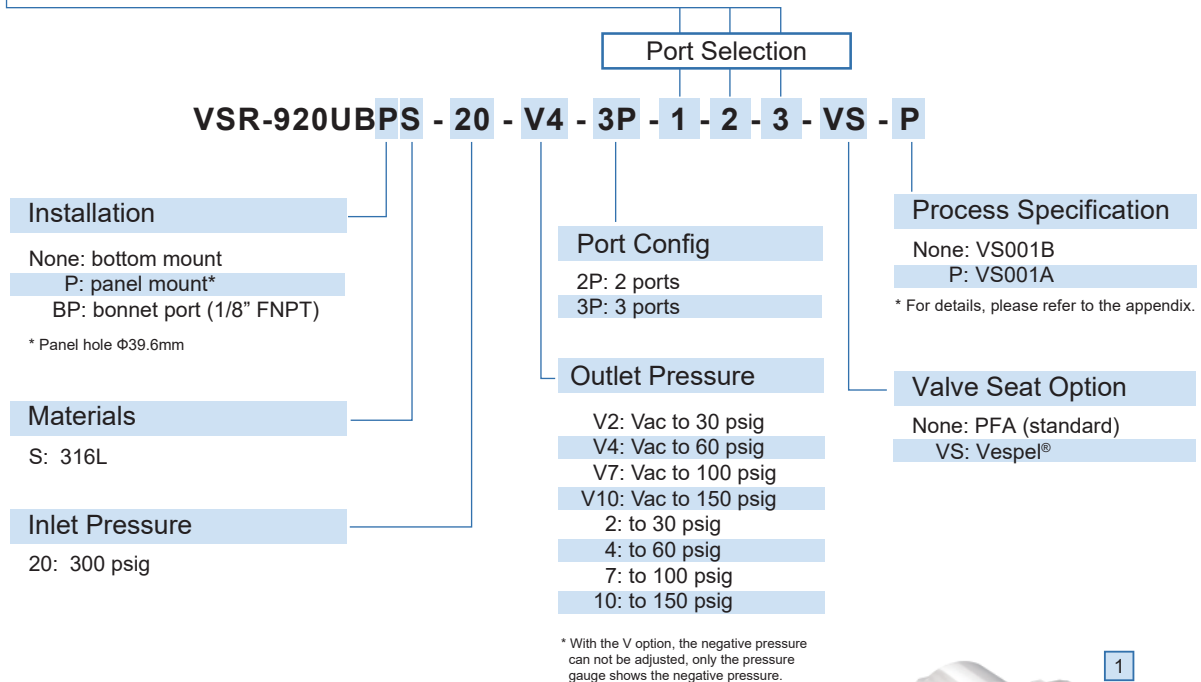

Ordering Example

VSR - 920UBS - 20 - 10 - 2P - MV12 - FV12

1 - 2



Single Stage Pressure Regulator

VSR-920UC Series

Product Feature

- Single-stage pressure regulator
- 10µin Ra average surface finish
(10µin. Ra max, 7µin. Ra max, 5µin. Ra max optional)
- Minimized internal volume for short purge times
- All materials used meet ASTM A479 / A484 / A276 standards
- Internal connectors for pressure gauges
- Flow capacity: to 2000 slpm
- High control accuracy
- Metal-to-metal seal to atmosphere
- Simple outlet pressure limitation by hand-wheel
- 100% helium-leak-tested
- Tied-diaphragm design



Dimensions (mm)

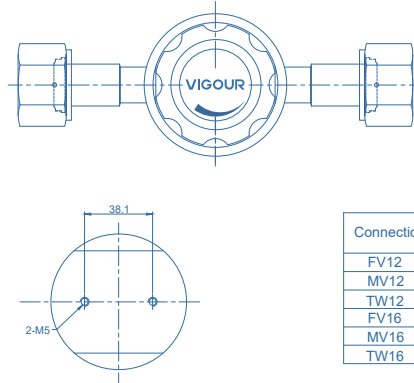
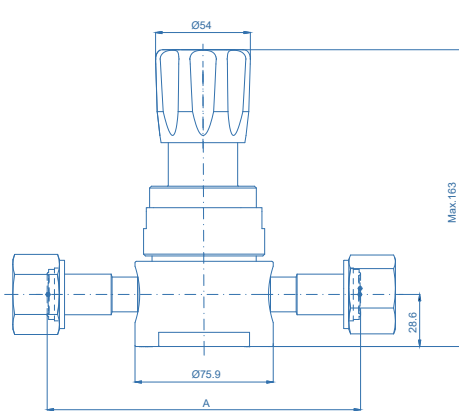

Connections	A	
	inch	(mm)
FV12	6.78	(172.2)
MV12	6.00	(152.4)
TW12	6.00	(152.4)
FV16	7.34	(186.4)
MV16	6.00	(152.4)
TW16	6.00	(152.4)

Technical Data

Type:	single-stage
Inlet pressure P1:	300 psig (20bar)
Outlet pressure P2:	Vac to 30/60/100/150 psig (2/4/7/10bar)
Surface finish:	10µin Ra average surface finish
Materials	(10µin. Ra max, 7µin. Ra max, 5µin. Ra max optional)
Body:	
Valve seat:	see ordering info
Diaphragm:	PFA (Vespel® optional)
Inlets and Outlets:	Hastelloy® C276
Bonnet port:	3/4" / 1" VFS fitting or tube weld
Temperature range:	1/8" FNPT(option)
Leak rate: (to atmosphere)	-40°F to +160°F (-40°C to +71°C)
(via seat)	1x10 ⁻⁹ mbar-l/s He
Flow capacity:	1x10 ⁻⁸ mbar-l/s He
Weight:	Cv=1.6
Supply pressure effect:	approx. 2.7kg (depending on connections or options)
	7 psig rise in delivery pressure per
	100 psig source pressure drop

Flowchart

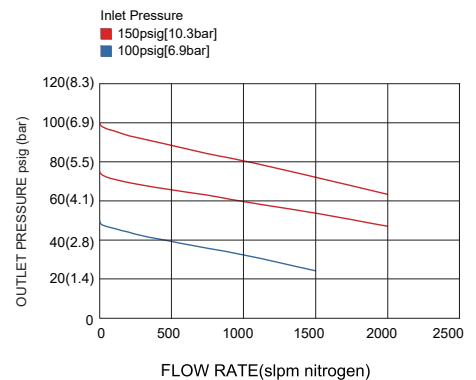

Single Stage Pressure Regulator VSR-920UC Series

Ordering Information

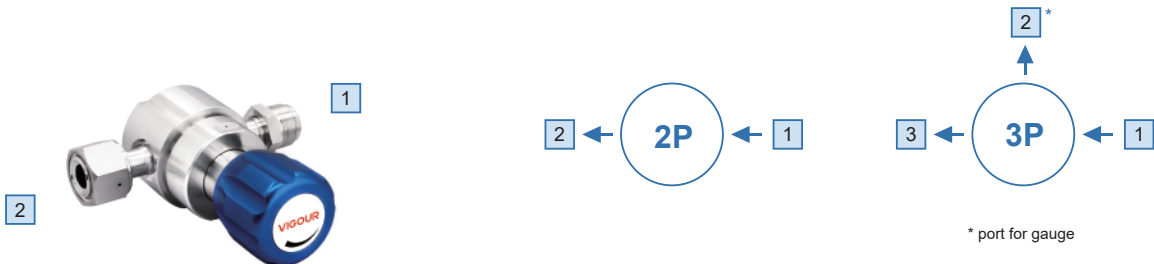

Inlet/Outlet Connection

FV12: 3/4" VFS female
MV12: 3/4" VFS male
FV16: 1" VFS female
MV16: 1" VFS male

FV4: 1/4" VFS female
MV4: 1/4" VFS male
IFV4: 1/4" (gauge female threaded connection machined on the body)

TW12: 3/4" tube weld
TW16: 1" tube weld
P: gauge (1/4" VFS fitting)
IP: gauge (IFV4 fitting)

* Other connection standard, consult factory

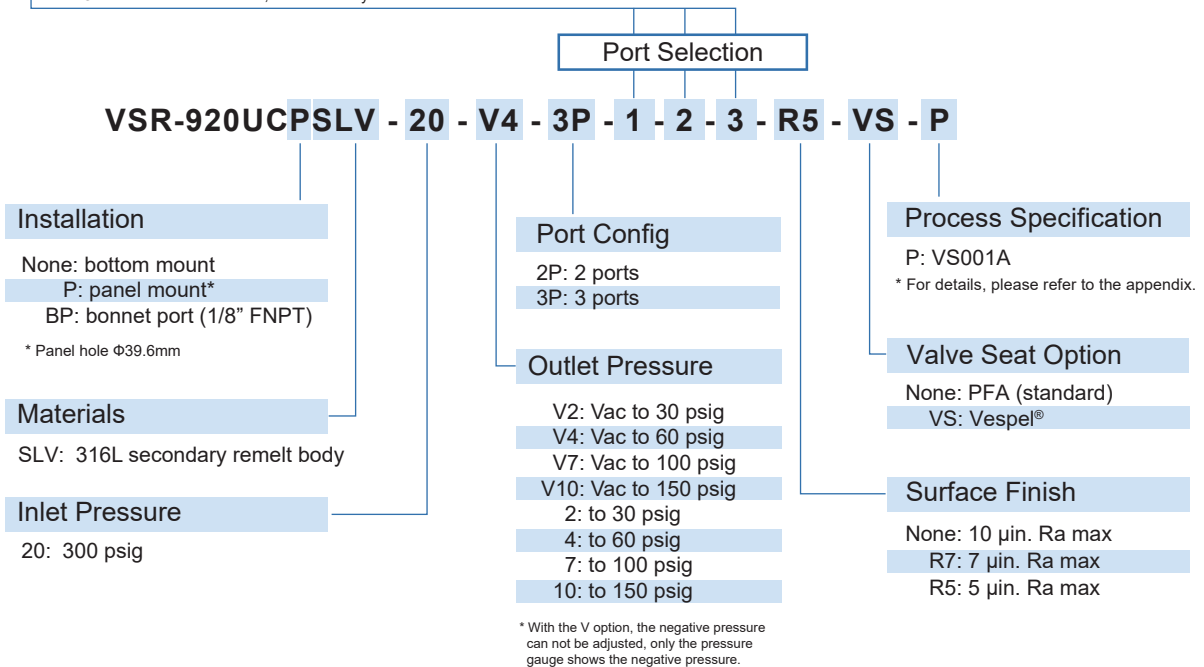

Ordering Example

VSR - 920UCSLV - 20 - 10 - 2P - MV12 - FV12

1 - 2



High Pressure Regulator

VSR-930UB Series

Product Feature

- Single-stage pressure regulator
- 10µin. Ra surface finish
- Minimized internal volume for short purge times
- Piston sensing element
- All materials used meet ASTM A479 / A484 / A276 standards
- Internal connectors for pressure gauges
- Flow capacity: to 30 slpm (standard), to 120 slpm (optional)
- High control accuracy
- Metal-to-metal seal to atmosphere
- Simple outlet pressure limitation by hand-wheel
- Applies only to inert gases

Dimensions (mm)

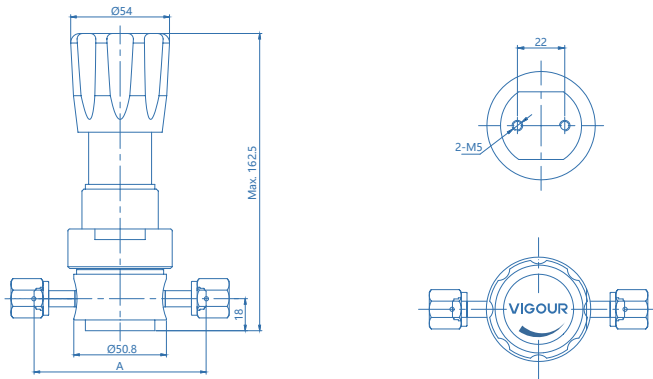

Connections	A	
	inch	mm
FV4	3.70	94
MV4		

Technical Data

Type:	single-stage
Inlet pressure P1:	5800 psig (400bar)
Outlet pressure P2:	500/2500 psig (35/170bar)
Surface finish:	10µin. Ra
Materials	
Body:	see ordering info
Valve seat:	PCTFE (VespeI® optional)
Diaphragm:	Hastelloy® C276
Inlets and Outlets:	1/4" VFS fitting and tube weld
Bonnet port:	1/8" NPT (on panel mount option, bonnet port is not threaded)
Temperature range:	0°F to +140°F (-18°C to +60°C)
Leak rate:	Bubble tight
Flow capacity:	Cv=0.09 (Cv=0.15 optional)
Weight:	approx. 2.0kg (depending on connections or options)

Flowchart

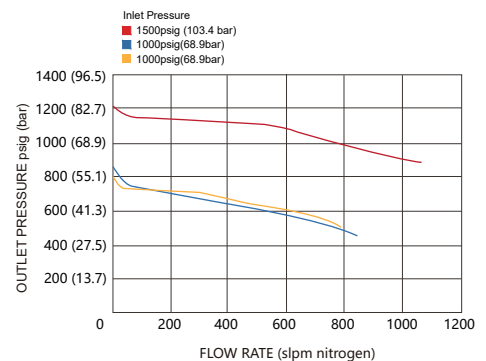

High Pressure Regulator VSR-930UB Series

Ordering Information

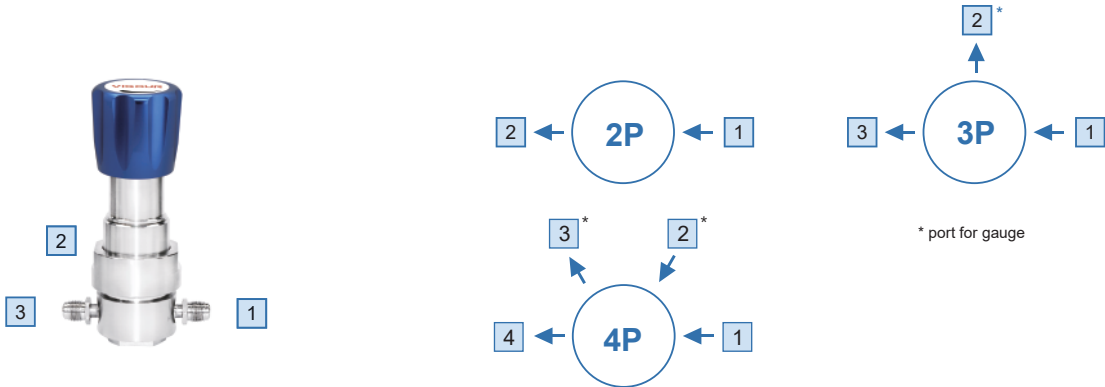

Inlet/outlet Connection

FV4: 1/4" VFS female
 MV4: 1/4" VFS male
 IFV4: 1/4" (gauge female threaded connection machined on the body)

TW4: 1/4" tube weld
 P: gauge (1/4" VFS fitting)
 IP: gauge (IFV4 fitting)

* Other connection standard, consult factory

Port Selection

VSR-930UBPS - 400 - 170 - 4P - 1 - 2 - 3 - 4 - HF - VS - X - P

Installation

None: bottom mount
 P: panel mount *

* Panel hole $\Phi 36\text{mm}$

Materials

S: 316L

Inlet Pressure

400: 5800 psig

Port Config

2P: 2 ports
 3P: 3 ports
 4P: 4 ports

Outlet Pressure

35: 25~500 psig
 170: 100 ~ 2500 psig

Process Specification

None: VS001B
 P: VS001A

* For details, please refer to the appendix.

Option

None: Self-relief
 X: Non-relief

Valve seat Option

None: PCTFE
 VS: Vespel®

Cv Option

None: Cv=0.09
 HF: Cv=0.15*

* The HF option uses only Vespel® valve seats.

Ordering Example

VSR - 930UBS - 400 - 170 - 3P - FV4 - P - FV4

1 - 2 - 3



Diaphragm Valve VDV32UB Series

Product Feature

- Suitable for ultra-pure, flammable or toxic fluid lines in semiconductor manufacturing equipment and facilities
- Direct diaphragm construction with superior sealing performance, remarkable durability, compactness and particle and dead-space-free performance
- Valve open and closed position is easily visible at a glance
- Excellent gas displacement characteristics
- EP treatment is standard for all wetted surfaces
- Standard seat material is PCTFE, Polyimide / PFA is option

Temperature / Pressure Rating

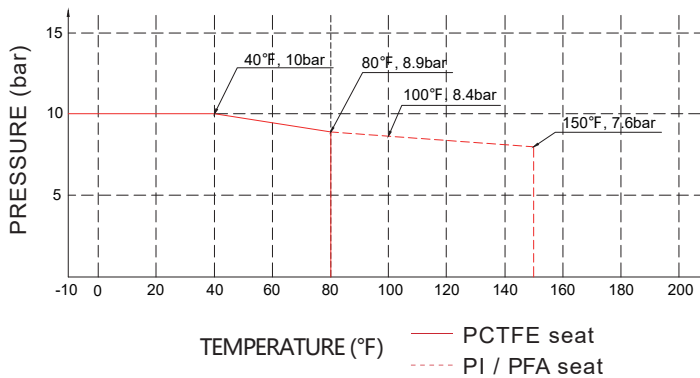

1/4 Type



1/4 Type (IS option)



1/2 Type



1/2 Type

Technical Data

Max. Working Pressure:	150 psig (10bar)
Actuation Pressure:	58~87psig (4~6bar)
Max. Working Temp.:	14°F ~ 176°F (-10°C ~ 80°C)
Surface finish:	10µin. Ra
Materials	
Body:	see ordering info
Diaphragm:	Elgiloy®
Seat packing:	PCTFE
Handle:	AL
Internal Leakage Allowance:	1x10 ⁻⁹ mbar·l/s He
External Leakage Allowance:	1x10 ⁻⁹ mbar·l/s He
Flow capacity:	1/4" Cv=0.3 3/8" 1/2" 3/4" Cv=0.65
Weight:	approx. 0.27kg (depending on connections or options)

Diaphragm Valve VDV32UB Series

Dimensions (mm)

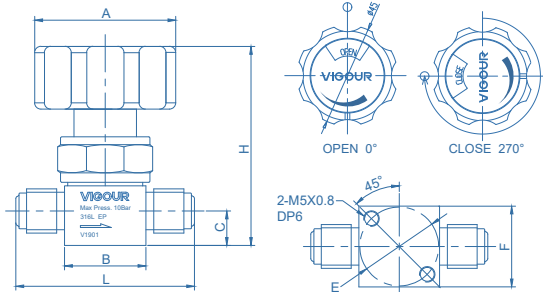

1/4, 3/8, 1/2 manual actuator (VFS male)

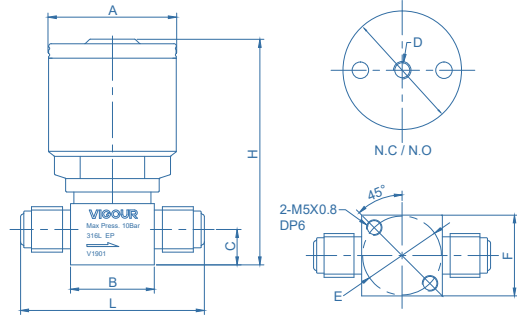

1/4 pneumatic actuator (VFS male)

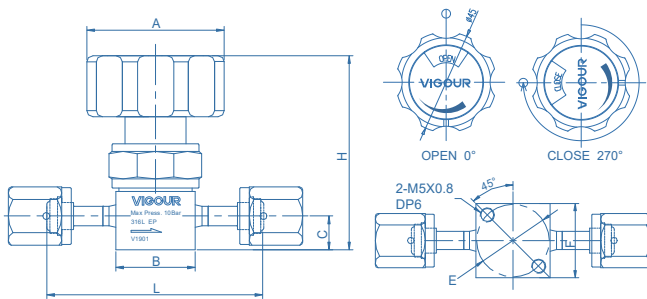

1/4, 1/2, 3/4 manual actuator (VFS female)

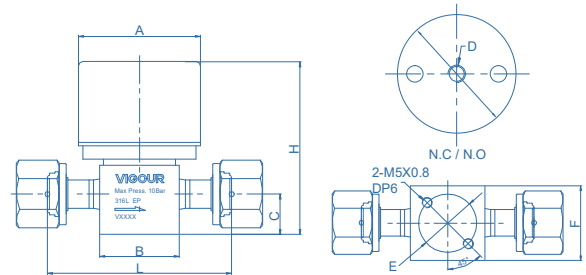

1/2 pneumatic actuator (VFS female)

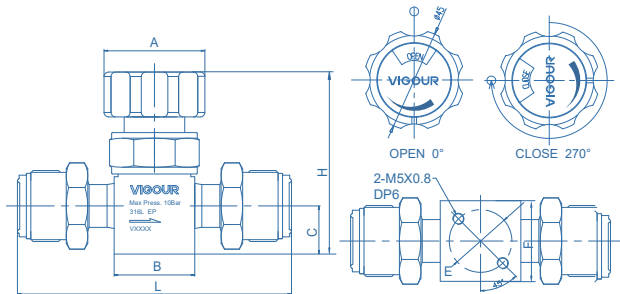

3/4 manual actuator (VFS male)

manual actuator

End Connections	Orifice (mm)	Dimensions (mm)						
		A	B	C	E	F	L	H
1/4" VFS male	4.4	Φ45	26	11	Φ25.4	26	57	64
1/4" VFS female	4.4	Φ45	26	11	Φ25.4	26	71	64
3/8" VFS male	7	Φ45	36	18.2	Φ28	36	77	78
1/2" VFS male	7	Φ45	36	18.2	Φ28	36	77	78
1/2" VFS female	7	Φ45	36	18.2	Φ28	36	83	78
3/4" VFS male	7	Φ45	36	21.5	Φ28	36	122.3	82
3/4" VFS female	7	Φ45	36	21.5	Φ28	36	106.3	82

pneumatic actuator, normally opened / normally closed

End Connections	Actuator	Orifice (mm)	Dimensions (mm)							
			A	B	C	D	E	F	L	H
1/4" VFS male	N.C / N.O	4.4	Φ39.6	26	11	M5x0.8	Φ25.4	26	57	70
1/4" VFS female	N.C / N.O	4.4	Φ39.6	26	11	M5x0.8	Φ25.4	26	71	70
3/8" VFS male	N.C / N.O	7	Φ55	36	18.2	RC 1/8	Φ28	36	77	78
1/2" VFS male	N.C / N.O	7	Φ55	36	18.2	RC 1/8	Φ28	36	77	78
1/2" VFS female	N.C / N.O	7	Φ55	36	18.2	RC 1/8	Φ28	36	83	78

Ordering information

VDV32UBS - M - A - MV4 - MV4 - PA - LOTOC - IS - P

Materials

S: 316L

Actuator

M: manual actuator
PO: pneumatic actuator, normally opened
PC: pneumatic actuator, normally closed

Flow Circuit Diagram

For details, refer to the flow circuit diagram on page 67.

End Connection

MV4: 1/4" VFS male	TW6: 3/8" tube weld
FV4: 1/4" VFS female	MV8: 1/2" VFS male
TW4: 1/4" tube weld	FV8: 1/2" VFS female
MV6: 1/2" VFS male 3/8" O.D.	TW8: 1/2" tube weld
FV6: 1/2" VFS female 3/8" O.D.	MV12: 3/4" VFS male
	FV12: 3/4" VFS female

* Other connection standard, consult factory

Valve Seat Option

None: PCTFE (standard)
VS: Vespel®
PA: PFA

Process Specification

none: VS001B
P: VS001A

* For details, please refer to the appendix.

Option

None: Standard
IS: Switch Position Indicator

Option

None: standard
LOTO: Closed Position Lock*
LOTOT: Open Position Lock*
LOTOTOC: Open / Closed Position Lock*

* Manual only

Diaphragm Valve VDV32UC Series

Product Feature

- Suitable for ultra-pure, flammable or toxic fluid lines in semiconductor manufacturing equipment and facilities
- Direct diaphragm construction with superior sealing performance, remarkable durability, compactness and particle and dead-space-free performance
- Valve open and closed position is easily visible at a glance
- Excellent gas displacement characteristics
- EP treatment is standard for all wetted surfaces
- Standard seat material is PCTFE, Polyimide / PFA is option

Temperature / Pressure Rating

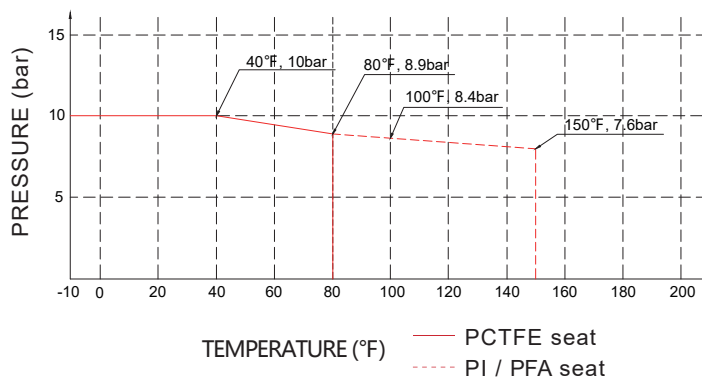

1/4 Type



1/4 Type (IS option)



1/2 Type



1/2 Type

Technical Data

Max. Working Pressure:	150 psig (10bar)
Actuation Pressure:	58~87psig (4~6bar)
Max. Working Temp.:	14°F ~ 176°F (-10°C ~ 80°C)
Surface finish:	7μin. Ra
Materials	
Body:	see ordering info
Diaphragm:	Elgiloy®
Seat packing:	PCTFE
Handle:	AL
Internal Leakage Allowance:	1x10 ⁻⁹ mbar·l/s He
External Leakage Allowance:	1x10 ⁻⁹ mbar·l/s He
Flow capacity:	1/4" Cv=0.3 3/8" 1/2" 3/4" Cv=0.65
Weight:	approx. 0.27kg (depending on connections or options)

Diaphragm Valve VDV32UC Series

Dimensions (mm)

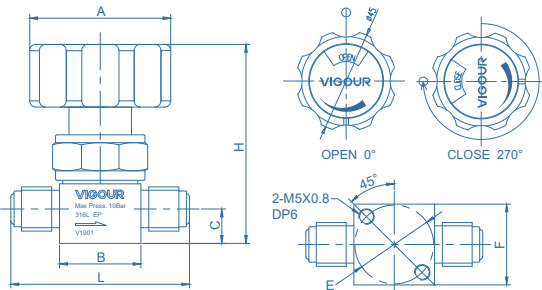

1/4, 3/8, 1/2 manual actuator (VFS male)

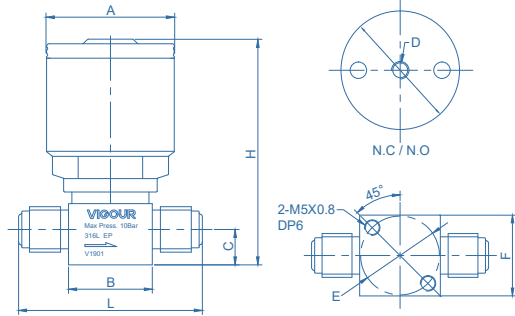

1/4 pneumatic actuator (VFS male)

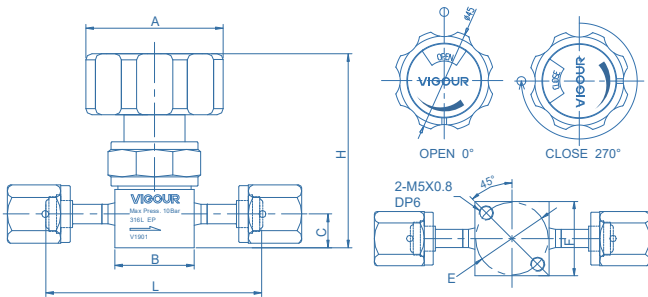

1/4, 1/2, 3/4 manual actuator (VFS female)

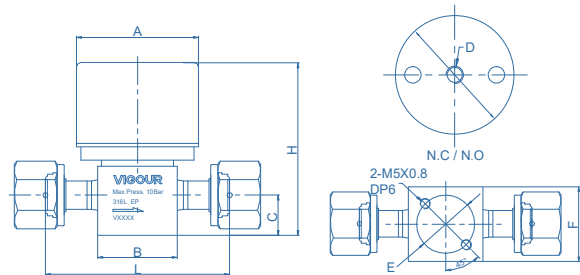

1/2 pneumatic actuator (VFS female)

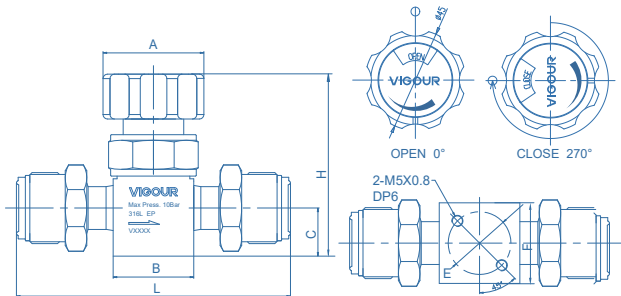

3/4 manual actuator (VFS male)

manual actuator

End Connections	Orifice (mm)	Dimensions (mm)							
		A	B	C	E	F	L	H	
1/4" VFS male	4.4	Φ45	26	11	Φ25.4	26	57	64	
1/4" VFS female	4.4	Φ45	26	11	Φ25.4	26	71	64	
3/8" VFS male	7	Φ45	36	18.2	Φ28	36	77	78	
1/2" VFS male	7	Φ45	36	18.2	Φ28	36	77	78	
1/2" VFS female	7	Φ45	36	18.2	Φ28	36	83	78	
3/4" VFS male	7	Φ45	36	21.5	Φ28	36	122.3	82	
3/4" VFS female	7	Φ45	36	21.5	Φ28	36	106.3	82	

pneumatic actuator, normally opened / normally closed

End Connections	Actuator	Orifice (mm)	Dimensions (mm)							
			A	B	C	D	E	F	L	H
1/4" VFS male	N.C / N.O	4.4	Φ39.6	26	11	M5x0.8	Φ25.4	26	57	70
1/4" VFS female	N.C / N.O	4.4	Φ39.6	26	11	M5x0.8	Φ25.4	26	71	70
3/8" VFS male	N.C / N.O	7	Φ55	36	18.2	RC 1/8	Φ28	36	77	78
1/2" VFS male	N.C / N.O	7	Φ55	36	18.2	RC 1/8	Φ28	36	77	78
1/2" VFS female	N.C / N.O	7	Φ55	36	18.2	RC 1/8	Φ28	36	83	78

Ordering information

VDV32UCSLV - M - A - MV4 - MV4 - PA - LOTOC - IS - P

Materials

SLV: 316L secondary remelt

Actuator

M: manual actuator
 PO: pneumatic actuator, normally opened
 PC: pneumatic actuator, normally closed

Flow Circuit Diagram

For details, refer to the flow circuit diagram on page 67.

End Connection

MV4: 1/4" VFS male
 FV4: 1/4" VFS female
 TW4: 1/4" tube weld
 MV6: 1/2" VFS male 3/8" O.D.
 FV6: 1/2" VFS female 3/8" O.D.
 TW6: 3/8" tube weld
 MV8: 1/2" VFS male
 FV8: 1/2" VFS female
 TW8: 1/2" tube weld
 MV12: 3/4" VFS male
 FV12: 3/4" VFS female

* Other connection standard, consult factory

Valve Seat Option

None: PCTFE (standard)
 VS: Vespel®
 PA: PFA

Process Specification

P: VS001A
 * For details, please refer to the appendix.

Option

None: Standard
 IS: Switch Position Indicator

Option

None: standard
 LOTO: Closed Position Lock*
 LOTC: Open Position Lock*
 LOTOC: Open / Closed Position Lock*

* Manual only

Diaphragm Valve VDV33UB Series

Product Feature

- Suitable for ultra-pure, flammable or toxic fluid lines in semiconductor manufacturing equipment and facilities
- Direct diaphragm construction with superior sealing performance, remarkable durability, compactness and particle and dead-space-free performance
- Valve open and closed position is easily visible at a glance
- Excellent gas displacement characteristics
- EP treatment is standard for all wetted surfaces
- Standard seat material is PCTFE, Polyimide / PFA is option



1/4 Type



1/4 Type



1/2 Type



1/2 Type

Temperature / Pressure Rating

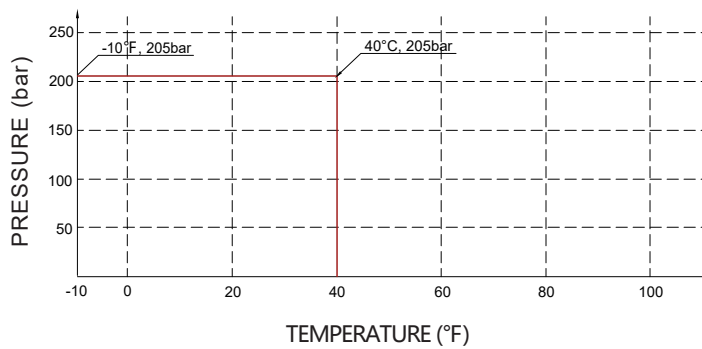

Technical Data

Max. Working Pressure:	3000 psig (200bar)
Actuation Pressure:	58~87psig (4~6bar)
Max. Working Temp.:	14°F ~ 104°F (-10°C ~ 40°C)
Surface finish:	10µin. Ra
Materials	
Body:	see ordering info
Diaphragm:	Elgiloy®
Seat packing:	PCTFE
Handle:	AL
Internal Leakage Allowance:	1x10 ⁻⁹ mbar·l/s He
External Leakage Allowance:	1x10 ⁻⁹ mbar·l/s He
Flow capacity:	1/4" Cv=0.27 3/8" 1/2" Cv=0.5
Weight:	approx. 0.27kg (depending on connections or options)

Diaphragm Valve VDV33UB Series

Dimensions (mm)

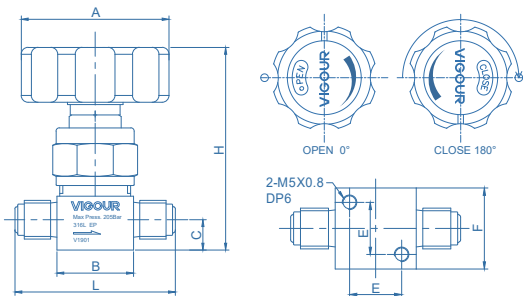

1/4 manual actuator (VFS male)

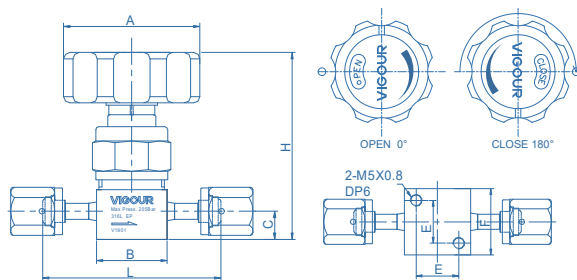

1/4 manual actuator (VFS female)

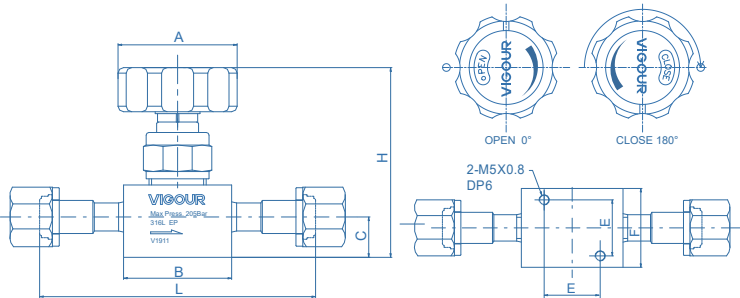

1/2 manual actuator (VFS female)

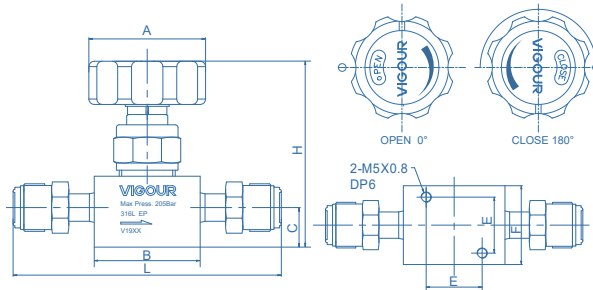

3/8, 1/2 manual actuator (VFS male)

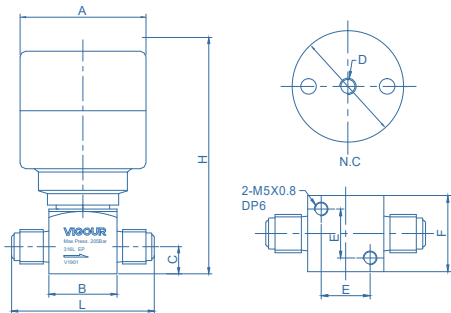

1/4 pneumatic actuator N.C. (VFS male)

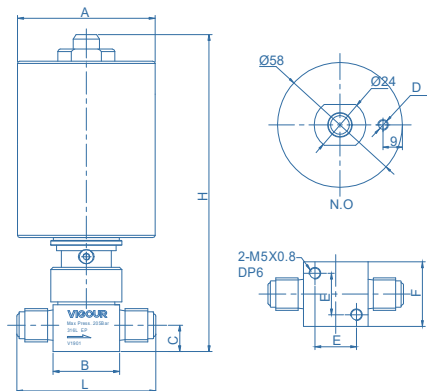

1/4 pneumatic actuator N.O. (VFS male)

Diaphragm Valve VDV33UB Series

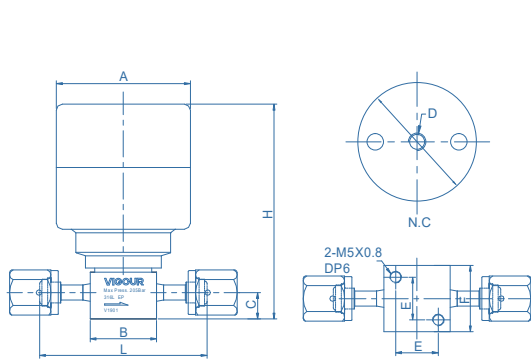

1/4 pneumatic actuator N.C. (VFS female)

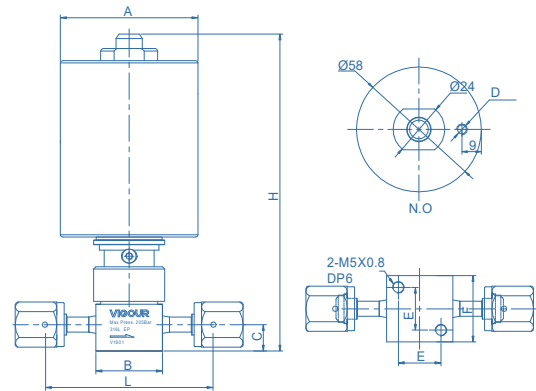

1/4 pneumatic actuator N.O. (VFS female)

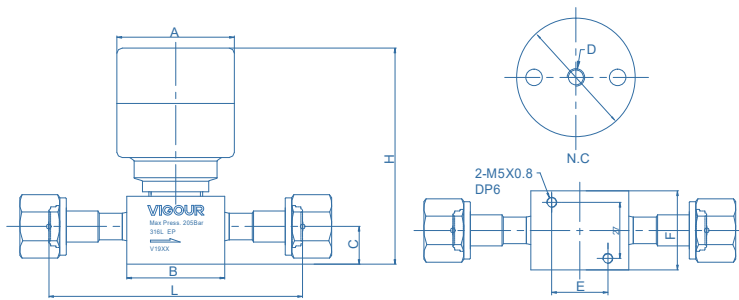

1/2 pneumatic actuator N.C. (VFS female)

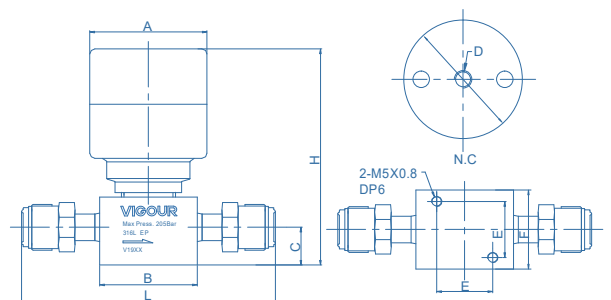

3/8, 1/2 pneumatic actuator N.C. (VFS male)

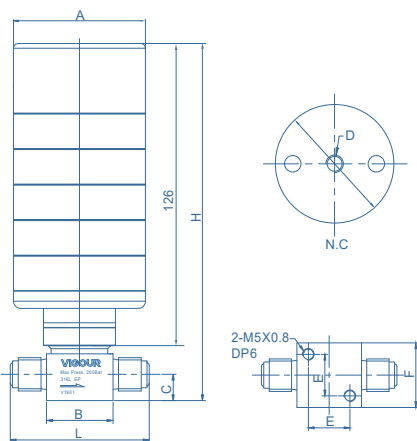

1/4 pneumatic actuator N.C. (VFS male) HPC

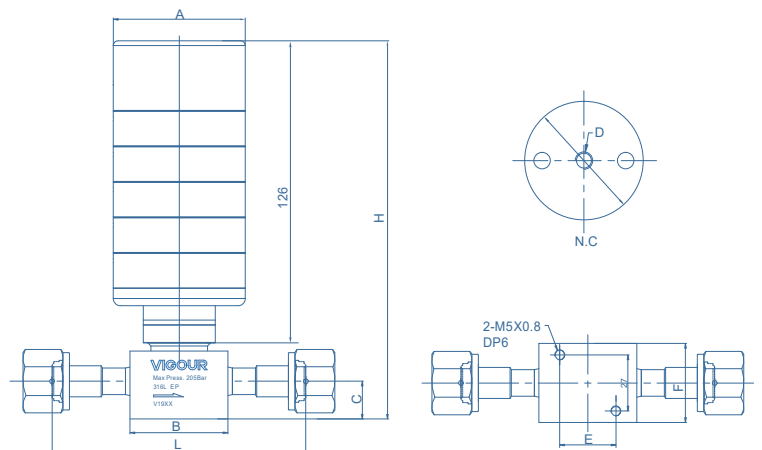

3/8, 1/2 pneumatic actuator N.C. (VFS female) HPC

Dimensions (mm)

manual actuator

End Connections	Orifice (mm)	Dimensions (mm)						
		A	B	C	E	F	L	H
1/4" VFS male	4.4	Φ54	28	11.1	18	28	58.7	74
1/4" VFS female	4.4	Φ54	28	11.1	18	28	71.6	74
3/8" VFS male	7	Φ54	47.1	18.2	27	38	123.2	86
1/2" VFS male	7	Φ54	47.1	18.2	27	38	123.2	86
1/2" VFS female	7	Φ54	47.1	18.2	27	38	123.2	86

1/4", 3/8", 1/2" VFS fitting dimensions for reference, other connections please contact factory.

pneumatic actuator, normally opened / normally closed

End Connections	Actuator	Orifice (mm)	Dimensions (mm)							
			A	B	C	D	E	F	L	H
1/4" VFS male	N.C	4.4	Φ56.5	28	11.1	M5x0.8	18	28	58.7	90.5
1/4" VFS male	N.O	4.4	Φ58	28	11.1	M5x0.8	18	28	58.7	134
1/4" VFS female	N.C	4.4	Φ56.5	28	11.1	M5x0.8	18	28	71.6	90.5
1/4" VFS female	N.O	4.4	Φ58	28	11.1	M5x0.8	18	28	71.6	134
3/8" VFS male	N.C	7	Φ56.5	47.1	18.2	M5x0.8	27	38	123.2	105
1/2" VFS male	N.C	7	Φ56.5	47.1	18.2	M5x0.8	27	38	123.2	105
1/2" VFS female	N.C	7	Φ56.5	47.1	18.2	M5x0.8	27	38	123.2	105



pneumatic actuator, normally closed (HPC)

End Connections	Actuator	Orifice (mm)	Dimensions (mm)							
			A	B	C	D	E	F	L	H
1/4" VFS male	N.C	4.4	Φ55	28	11.1	M5x0.8	18	28	58.7	148.6
1/4" VFS female	N.C	4.4	Φ55	28	11.1	M5x0.8	18	28	71.6	148.6
3/8" VFS male	N.C	7	Φ55	47.1	18.2	M5x0.8	27	38	123.2	162
1/2" VFS male	N.C	7	Φ55	47.1	18.2	M5x0.8	27	38	123.2	162
1/2" VFS female	N.C	7	Φ55	47.1	18.2	M5x0.8	27	38	123.2	162

Ordering Information

VDV33UBS - M - A - MV4 - MV4 - PA - P

Materials

S: 316L

Actuator

M: manual actuator

PO: pneumatic actuator, normally opened *

PC: pneumatic actuator, normally closed

HPC: The multi-stage cylinder design ensures a more linear sealing process.

* Normally opened available with connection size 1/4"

Flow Circuit Diagram

For details, refer to the flow circuit diagram on page 67.

Process Specification

none: VS001B

P: VS001A

* For details, please refer to the appendix.

Valve Seat Option

None: PCTFE (standard)

VS: Vespel®

PA: PFA

End Connection

MV4: 1/4" VFS male

FV4: 1/4" VFS female

TW4: 1/4" tube weld

TW6: 3/8" tube weld

RMV8: 1/2" VFS Rotatable male

FV8: 1/2" VFS female

TW8: 1/2" tube weld

* Other connection standard, consult factory

Diaphragm Valve VDV33UC Series

Product Feature

- Suitable for ultra-pure, flammable or toxic fluid lines in semiconductor manufacturing equipment and facilities
- Direct diaphragm construction with superior sealing performance, remarkable durability, compactness and particle and dead-space-free performance
- Valve open and closed position is easily visible at a glance
- Excellent gas displacement characteristics
- EP treatment is standard for all wetted surfaces
- Standard seat material is PCTFE, Polyimide / PFA is option

Temperature / Pressure Rating

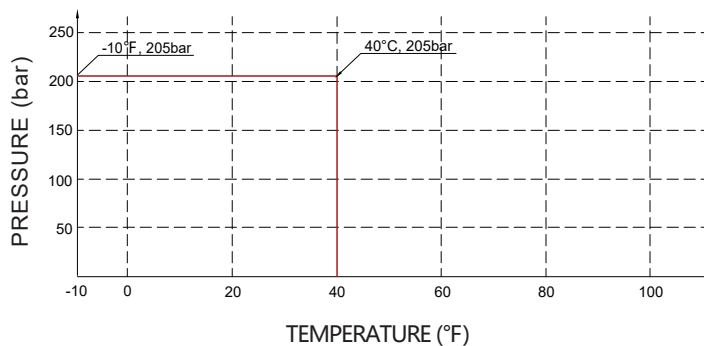

1/4 Type



1/4 Type



1/2 Type



1/2 Type

Technical Data

Max. Working Pressure:	3000 psig (200bar)
Actuation Pressure:	58~87psig (4~6bar)
Max. Working Temp.:	14°F ~ 104°F (-10°C ~ 40°C)
Surface finish:	7µin. Ra
Materials	
Body:	see ordering info
Diaphragm:	Elgiloy®
Seat packing:	PCTFE
Handle:	AL
Internal Leakage Allowance:	1x10 ⁻⁹ mbar·l/s He
External Leakage Allowance:	1x10 ⁻⁹ mbar·l/s He
Flow capacity:	1/4" Cv=0.27 3/8" 1/2" Cv=0.5
Weight:	approx. 0.27kg (depending on connections or options)

Diaphragm Valve VDV33UC Series

Dimensions (mm)

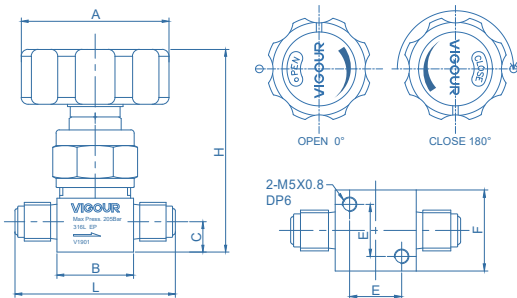

1/4 manual actuator (VFS male)

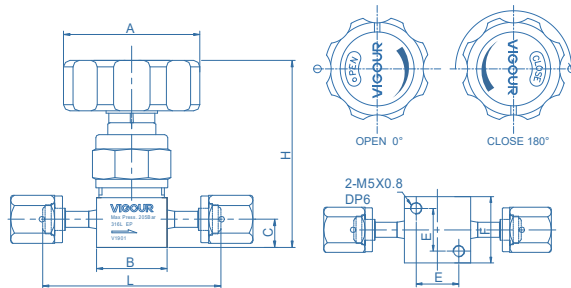

1/4 manual actuator (VFS female)

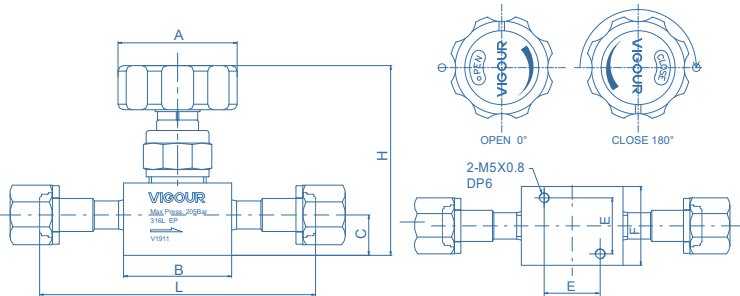

1/2 manual actuator (VFS female)

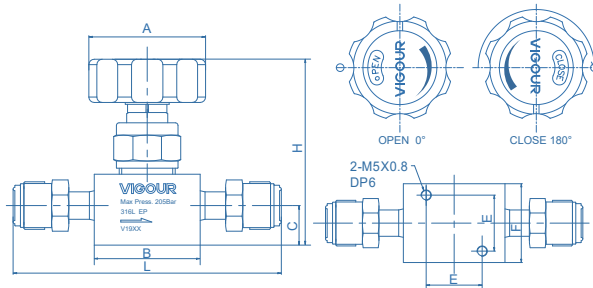

3/8, 1/2 manual actuator (VFS male)

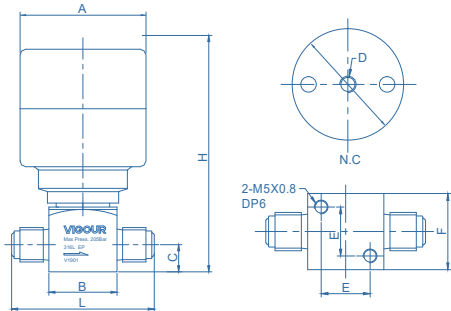

1/4 pneumatic actuator N.C. (VFS male)

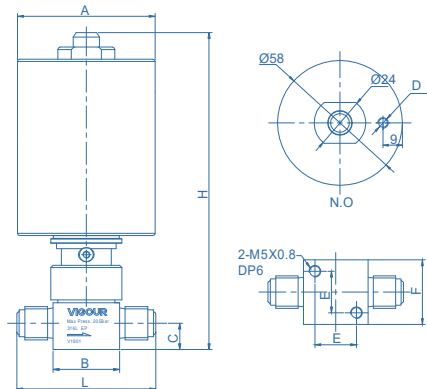

1/4 pneumatic actuator N.O. (VFS male)

Diaphragm Valve VDV33UC Series

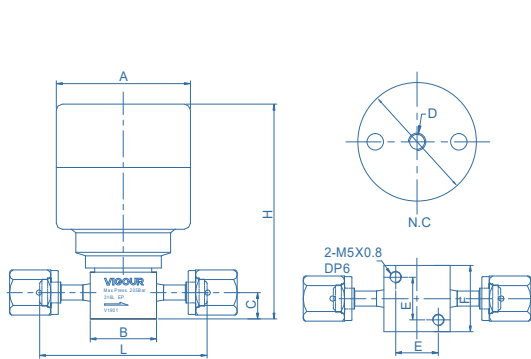

1/4 pneumatic actuator N.C. (VFS female)

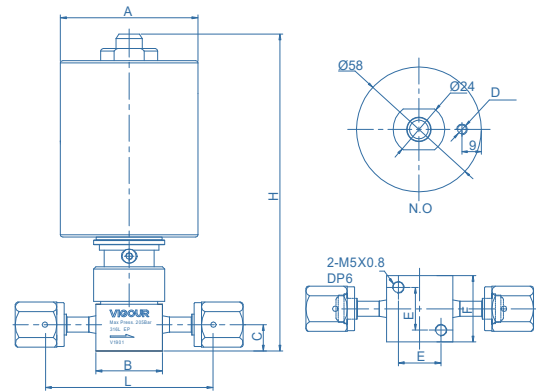

1/4 pneumatic actuator N.O. (VFS female)

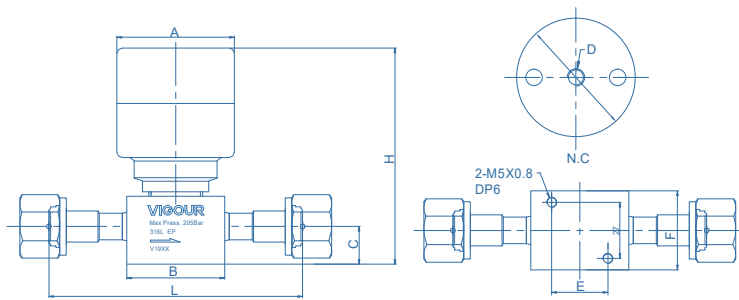

1/2 pneumatic actuator N.C. (VFS female)

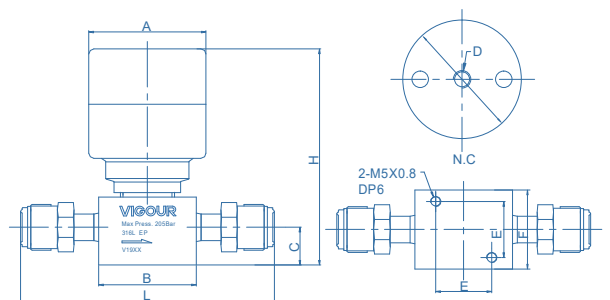

3/8, 1/2 pneumatic actuator N.C. (VFS male)

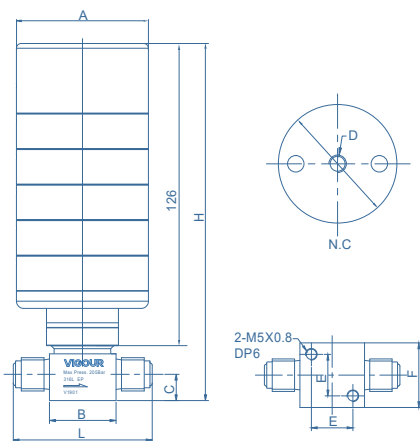

1/4 pneumatic actuator N.C. (VFS female) HPC

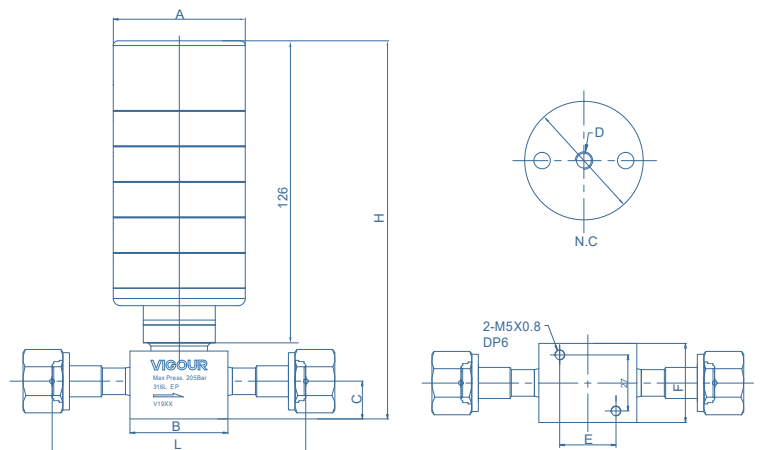

3/8, 1/2 pneumatic actuator N.C. (VFS male) HPC

Dimensions (mm)

manual actuator

End Connections	Orifice (mm)	Dimensions (mm)						
		A	B	C	E	F	L	H
1/4" VFS male	4.4	Φ54	28	11.1	18	28	58.7	74
1/4" VFS female	4.4	Φ54	28	11.1	18	28	71.6	74
3/8" VFS male	7	Φ54	47.1	18.2	27	38	123.2	86
1/2" VFS male	7	Φ54	47.1	18.2	27	38	123.2	86
1/2" VFS female	7	Φ54	47.1	18.2	27	38	123.2	86

1/4", 3/8", 1/2" VFS fitting dimensions for reference, other connections please contact factory.

pneumatic actuator, normally opened / normally closed

End Connections	Actuator	Orifice (mm)	Dimensions (mm)							
			A	B	C	D	E	F	L	H
1/4" VFS male	N.C	4.4	Φ56.5	28	11.1	M5x0.8	18	28	58.7	90.5
1/4" VFS male	N.O	4.4	Φ58	28	11.1	M5x0.8	18	28	58.7	134
1/4" VFS female	N.C	4.4	Φ56.5	28	11.1	M5x0.8	18	28	71.6	90.5
1/4" VFS female	N.O	4.4	Φ58	28	11.1	M5x0.8	18	28	71.6	134
3/8" VFS male	N.C	7	Φ56.5	47.1	18.2	M5x0.8	27	38	123.2	105
1/2" VFS male	N.C	7	Φ56.5	47.1	18.2	M5x0.8	27	38	123.2	105
1/2" VFS female	N.C	7	Φ56.5	47.1	18.2	M5x0.8	27	38	123.2	105

pneumatic actuator, normally closed (HPC)



End Connections	Actuator	Orifice (mm)	Dimensions (mm)							
			A	B	C	D	E	F	L	H
1/4" VFS male	N.C	4.4	Φ55	28	11.1	M5x0.8	18	28	58.7	148.6
1/4" VFS female	N.C	4.4	Φ55	28	11.1	M5x0.8	18	28	71.6	148.6
3/8" VFS male	N.C	7	Φ55	47.1	18.2	M5x0.8	27	38	123.2	162
1/2" VFS male	N.C	7	Φ55	47.1	18.2	M5x0.8	27	38	123.2	162
1/2" VFS female	N.C	7	Φ55	47.1	18.2	M5x0.8	27	38	123.2	162

Ordering Information

VDV33UCSLV - M - A - MV4 - MV4 - PA - P

Materials

SLV: 316L secondary remelt

Actuator

M: manual actuator

PO: pneumatic actuator, normally opened *

PC: pneumatic actuator, normally closed

HPC: The multi-stage cylinder design ensures a more linear sealing process.

* Normally opened available with connection size 1/4"

Flow Circuit Diagram

For details, refer to the flow circuit diagram on page 67.

Process Specification

P: VS001A

* For details, please refer to the appendix.

Valve Seat Option

None: PCTFE(standard)

VS: Vespel®

PA: PFA

End Connection

MV4: 1/4" VFS male

FV4: 1/4" VFS female

TW4: 1/4" tube weld

TW6: 3/8" tube weld

RMV8: 1/2" VFS Rotatable male

FV8: 1/2" VFS female

TW8: 1/2" tube weld

* Other connection standard, consult factory

Diaphragm Valve VDV40UB Series

Product Feature

- Suitable for ultra-pure, flammable or toxic fluid lines in semiconductor manufacturing equipment and facilities
- Direct diaphragm construction with superior sealing performance, remarkable durability, compactness and particle free performance
- The product is fabricated in compliance with the VS001A process specification
- Valve open and closed position is easily visible at a glance
- Excellent gas displacement characteristics
- EP treatment is standard for all wetted surfaces
- Standard seat material is PCTFE, Polyimide is option



1/4" pneumatic actuator



1/4" manual actuator



1/4" Right-angle handle



1/4" manual actuator (Lockable)

Temperature / Pressure Rating

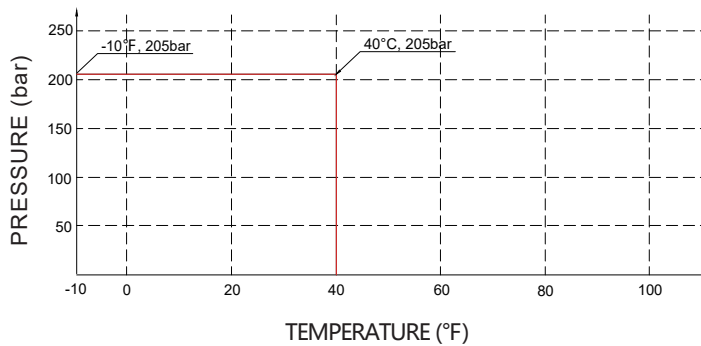

Technical Data

Max. Working Pressure:	3000 psig (200bar)
Actuation Pressure:	70~110 psig (5~8bar)
Max. Working Temp.:	-40°F ~ 160°F (-40°C ~ 71°C)
Surface finish:	10µin. Ra
Materials	
Body:	see ordering info
Diaphragm:	Elgiloy®
Seat packing:	PCTFE
Handle:	AL
Internal Leakage Allowance:	1x10 ⁻⁹ mbar·l/s He
External Leakage Allowance:	1x10 ⁻⁹ mbar·l/s He
Flow capacity:	pneumatic actuator Cv=0.23 manual actuator Cv=0.29
Weight:	approx 1.27kg (depending on connections or options)

Dimensions (mm)

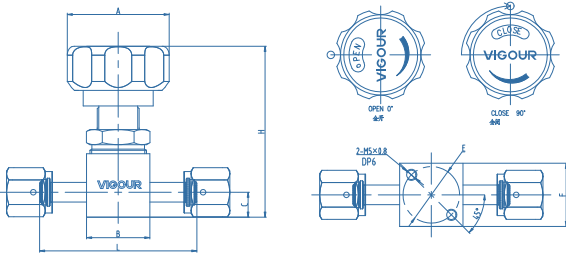

manual actuator

End Connections	Orifice (mm)	Dimensions (mm)						
		A	B	C	E	F	L	H
1/4" VFS male	4.4	Φ47.5	28.4	11.2	Φ25.4	28.4	70.6	77
1/4" VFS female	4.4	Φ47.5	28.4	11.2	Φ25.4	28.4	70.6	77
3/8" VFS male	4.4	Φ47.5	28.4	11.2	Φ25.4	28.4	98	77
3/8" VFS female	4.4	Φ47.5	28.4	11.2	Φ25.4	28.4	98	77
1/4" Tube weld	4.4	Φ47.5	28.4	11.2	Φ25.4	28.4	53.8	77
3/8" Tube weld	4.4	Φ47.5	28.4	11.2	Φ25.4	28.4	67.4	77

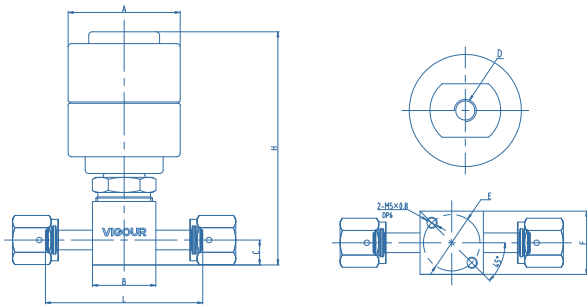

pneumatic actuator (normally closed)

End Connections	Orifice (mm)	Dimensions (mm)							
		A	B	C	D	E	F	L	H
1/4" VFS male	4.4	Φ50.3	28.4	11.2	M5x0.8	Φ25.4	28.4	70.6	105
1/4" VFS female	4.4	Φ50.3	28.4	11.2	M5x0.8	Φ25.4	28.4	70.6	105
3/8" VFS male	4.4	Φ50.3	28.4	11.2	M5x0.8	Φ25.4	28.4	98	105
3/8" VFS female	4.4	Φ50.3	28.4	11.2	M5x0.8	Φ25.4	28.4	98	105
1/4" Tube weld	4.4	Φ50.3	28.4	11.2	M5x0.8	Φ25.4	28.4	53.8	105
3/8" Tube weld	4.4	Φ50.3	28.4	11.2	M5x0.8	Φ25.4	28.4	67.4	105

Ordering Information

VDV40UBS - M - A - MV4 - MV4 - VS - LO - P

Materials

S: 316L

Actuator

M: manual actuator

PC: pneumatic actuator (normally closed)

Flow Circuit Diagram

For details, refer to the flow circuit diagram on page 67.

End Connection

MV4: 1/4" VFS male

FV4: 1/4" VFS female

TW4: 1/4" tube weld

MV6: 1/2" VFS male 3/8" O.D.

FV6: 1/2" VFS female 3/8" O.D.

TW6: 3/8" tube weld

* Other connection standard, consult factory

Process Specification

None: VS001B

P: VS001A

* For details, please refer to the appendix..

Optional

None: Round Knob

LO: Round Knob

Pull, then turn to open
lock out / tag out

L: Right-angle handle

Valve Seat Option

None: PCTFE (standard)

VS: Vespel®

Diaphragm Valve VDV40UC Series

Product Feature

- Suitable for ultra-pure, flammable or toxic fluid lines in semiconductor manufacturing equipment and facilities
- Direct diaphragm construction with superior sealing performance, remarkable durability, compactness and particle free performance
- Valve open and closed position is easily visible at a glance
- Excellent gas displacement characteristics
- EP treatment is standard for all wetted surfaces
- Standard seat material is PCTFE, Polyimide is option



1/4" pneumatic actuator



1/4" manual actuator



1/4" Right-angle handle



1/4" manual actuator (Lockable)

Temperature / Pressure Rating

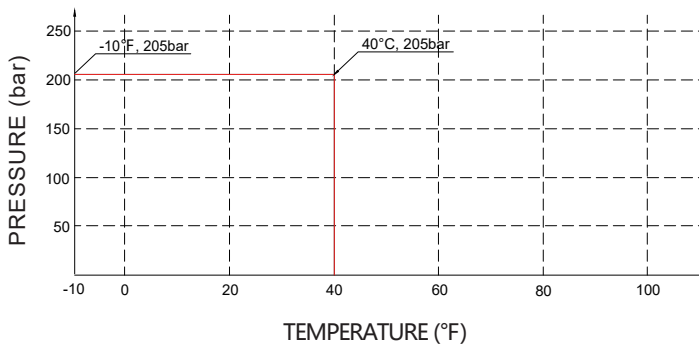

Technical Data

Max. Working Pressure:	3000 psig (200bar)
Actuation Pressure:	70~110 psig (5~8bar)
Max. Working Temp.:	-40°F ~ 160°F (-40°C ~ 71°C)
Surface finish:	7µin. Ra
Materials	
Body:	see ordering info
Diaphragm:	Elgiloy®
Seat packing:	PCTFE
Handle:	AL
Internal Leakage Allowance:	1x10 ⁻⁹ mbar·l/s He
External Leakage Allowance:	1x10 ⁻⁹ mbar·l/s He
Flow capacity:	pneumatic actuator Cv=0.23 manual actuator Cv=0.29
Weight:	approx 1.27kg (depending on connections or options)

Diaphragm Valve VDV40UC Series

Dimensions (mm)

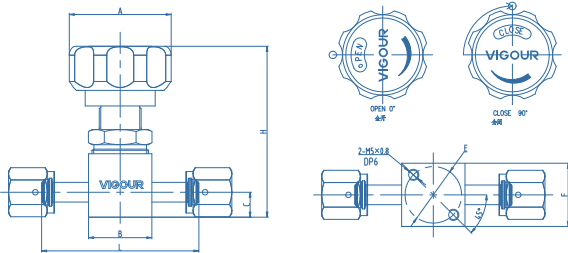

manual actuator

End Connections	Orifice (mm)	Dimensions (mm)						
		A	B	C	E	F	L	H
1/4" VFS male	4.4	Φ47.5	28.4	11.2	Φ25.4	28.4	70.6	77
1/4" VFS female	4.4	Φ47.5	28.4	11.2	Φ25.4	28.4	70.6	77
3/8" VFS male	4.4	Φ47.5	28.4	11.2	Φ25.4	28.4	98	77
3/8" VFS female	4.4	Φ47.5	28.4	11.2	Φ25.4	28.4	98	77
1/4" Tube weld	4.4	Φ47.5	28.4	11.2	Φ25.4	28.4	53.8	77
3/8" Tube weld	4.4	Φ47.5	28.4	11.2	Φ25.4	28.4	67.4	77

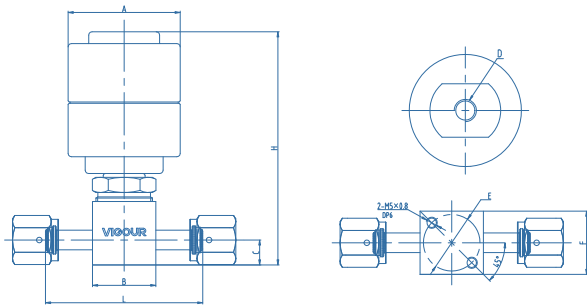

pneumatic actuator (normally closed)

End Connections	Orifice (mm)	Dimensions (mm)							
		A	B	C	D	E	F	L	H
1/4" VFS male	4.4	Φ50.3	28.4	11.2	M5x0.8	Φ25.4	28.4	70.6	105
1/4" VFS female	4.4	Φ50.3	28.4	11.2	M5x0.8	Φ25.4	28.4	70.6	105
3/8" VFS male	4.4	Φ50.3	28.4	11.2	M5x0.8	Φ25.4	28.4	98	105
3/8" VFS female	4.4	Φ50.3	28.4	11.2	M5x0.8	Φ25.4	28.4	98	105
1/4" Tube weld	4.4	Φ50.3	28.4	11.2	M5x0.8	Φ25.4	28.4	53.8	105
3/8" Tube weld	4.4	Φ50.3	28.4	11.2	M5x0.8	Φ25.4	28.4	67.4	105

Ordering Information

VDV40UCSLV - M - A - MV4 - MV4 - VS - LO - P

Materials

SLV: 316L secondary remelt

Actuator

M: manual actuator

PC: pneumatic actuator (normally closed)

Flow Circuit Diagram

For details, refer to the flow circuit diagram on page 67.

End Connection

MV4: 1/4" VFS male

FV4: 1/4" VFS female

TW4: 1/4" tube weld

MV6: 1/2" VFS male 3/8" O.D.

FV6: 1/2" VFS female 3/8" O.D.

TW6: 3/8" tube weld

Process Specification

P: VS001A

* For details, please refer to the appendix..

Optional

None: Round Knob

LO: Round Knob

Pull, then turn to open

lock out / tag out

L: Right-angle handle

Valve Seat Option

None: PCTFE (standard)

VS: VespeI®

* Other connection standard, consult factory

Diaphragm Valve VDV42UB Series

Product Feature

- Suitable for ultra-pure, flammable or toxic fluid lines in semiconductor manufacturing equipment and facilities
- Direct diaphragm construction with superior sealing performance, remarkable durability, compactness and particle and dead-space-free performance
- Valve open and closed position is easily visible at a glance
- Excellent gas displacement characteristics
- EP treatment is standard for all wetted surfaces
- Standard seat material is PCTFE, Polyimide / PFA is option

Temperature / Pressure Rating

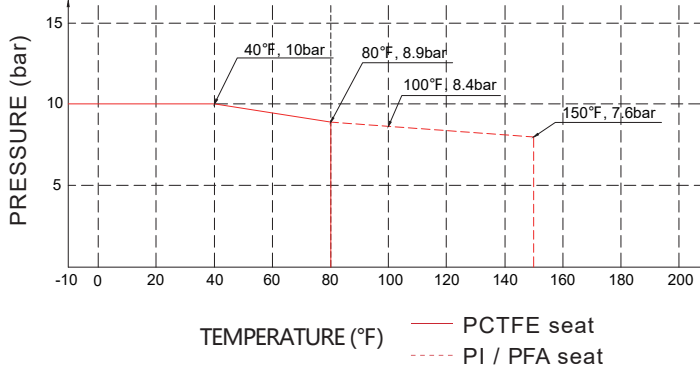

Information on Repair Kit Ordering



Ordering Number	Seat material	Description	Explanation
DV42-WXB-316L-PCTFE	PCTFE	Including 1 pc of valve seat assembly and 2 pcs of diaphragms.	Suitable for replaceable seat diaphragm valves.
DV42-WXB-316L-VespeI	VespeI		
DV42-WXB-316L-PFA	PFA		

Technical Data

Max. Working Pressure:	300 psig (20bar)
Actuation Pressure:	58~87psig (4~6bar)
Max. Working Temp.:	14°F ~ 176°F (-10°C ~ 80°C)
Surface finish:	10µin. Ra
Materials	
Body:	see ordering info
Diaphragm:	Elgiloy®
Seat packing:	PCTFE
Handle:	AL
Internal Leakage Allowance:	1x10 ⁻⁹ mbar-l/s He
External Leakage Allowance:	1x10 ⁻⁹ mbar-l/s He
Flow capacity:	1/4" Cv=0.3 3/8" 1/2" Cv=0.65
Weight:	approx. 0.27kg (depending on connections or options)



1/4 Type



1/4 Type (IS option)



1/2 Type



1/2 Type

Diaphragm Valve VDV42UB Series

Dimensions (mm)

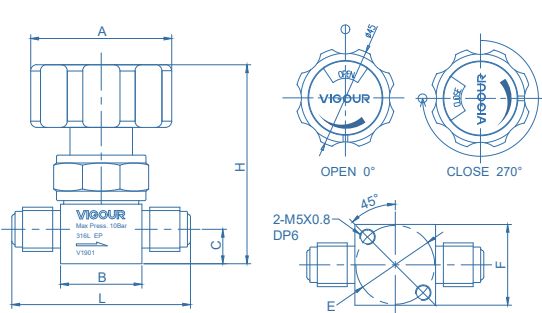

1/4, 3/8, 1/2 manual actuator (VFS male)

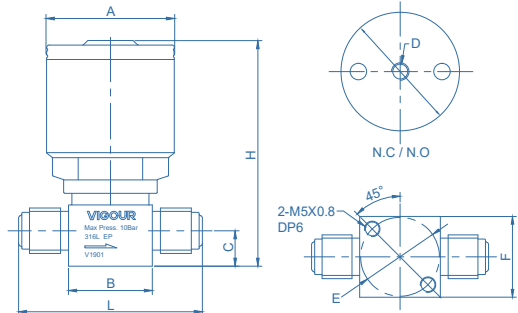

1/4 pneumatic actuator (VFS male)

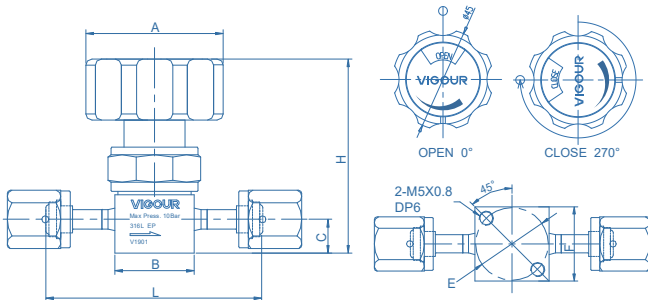

1/4, 1/2 manual actuator (VFS female)

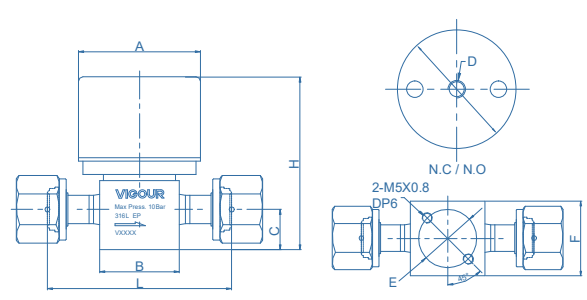

1/2 pneumatic actuator (VFS female)

manual actuator

End Connections	Orifice (mm)	Dimensions (mm)						
		A	B	C	E	F	L	H
1/4" VFS male	4.4	Φ45	26	11	Φ25.4	26	57	69
1/4" VFS female	4.4	Φ45	26	11	Φ25.4	26	71	69
3/8" VFS male	7	Φ45	36	18.2	Φ28	36	77	83
1/2" VFS male	7	Φ45	36	18.2	Φ28	36	77	83
1/2" VFS female	7	Φ45	36	18.2	Φ28	36	83	83

pneumatic actuator, normally opened / normally closed

End Connections	Actuator	Orifice (mm)	Dimensions (mm)							
			A	B	C	D	E	F	L	H
1/4" VFS male	N.C / N.O	4.4	Φ39.6	26	11	M5x0.8	Φ25.4	26	57	75
1/4" VFS female	N.C / N.O	4.4	Φ39.6	26	11	M5x0.8	Φ25.4	26	71	75
3/8" VFS male	N.C / N.O	7	Φ55	36	18.2	RC 1/8	Φ28	36	77	83
1/2" VFS male	N.C / N.O	7	Φ55	36	18.2	RC 1/8	Φ28	36	77	83
1/2" VFS female	N.C / N.O	7	Φ55	36	18.2	RC 1/8	Φ28	36	83	83

Ordering information

VDV42UBS - M - A - MV4 - MV4 - PA - LOTOC - IS - P

Materials

S: 316L

Actuator

M: manual actuator
PO: pneumatic actuator, normally opened
PC: pneumatic actuator, normally closed

Flow Circuit Diagram

For details, refer to the flow circuit diagram on page 67.

End Connection

MV4: 1/4" VFS male
FV4: 1/4" VFS female
TW4: 1/4" tube weld
MV6: 1/2" VFS male 3/8" O.D.
FV6: 1/2" VFS female 3/8" O.D.

TW6: 3/8" tube weld
MV8: 1/2" VFS male
FV8: 1/2" VFS female
TW8: 1/2" tube weld

* Other connection standard, consult factory

Valve Seat Option

None: PCTFE (standard)
VS: Vespe[®]
PA: PFA

Process Specification

none: VS001B
P: VS001A

* For details, please refer to the appendix.

Option

None: Standard
IS: Switch Position Indicator

Option

None: standard
LOTO: Closed Position Lock
LOT: Open Position Lock
LOTOC: Open / Closed Position Lock

* Manual only

Diaphragm Valve VDV42UC Series

Product Feature

- Suitable for ultra-pure, flammable or toxic fluid lines in semiconductor manufacturing equipment and facilities
- Direct diaphragm construction with superior sealing performance, remarkable durability, compactness and particle and dead-space-free performance
- Valve open and closed position is easily visible at a glance
- Excellent gas displacement characteristics
- EP treatment is standard for all wetted surfaces
- Standard seat material is PCTFE, Polyimide / PFA is option

Temperature / Pressure Rating

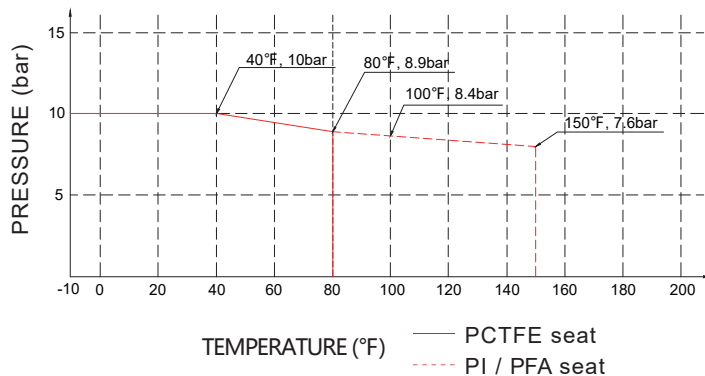

Information on Repair Kit Ordering



Ordering Number	Seat material	Description	Explanation
DV42-WXB-316L S.R-PCTFE	PCTFE	Including 1 pc of valve seat assembly and 2 pcs of diaphragms.	Suitable for replaceable seat diaphragm valves.
DV42-WXB-316L S.R-Vespel	Vespel		
DV42-WXB-316L S.R-PFA	PFA		

Technical Data

Max. Working Pressure:	300 psig (20bar)
Actuation Pressure:	58~87psig (4~6bar)
Max. Working Temp.:	14°F ~ 176°F (-10°C ~ 80°C)
Surface finish:	7µin. Ra
Materials	
Body:	see ordering info
Diaphragm:	Elgiloy®
Seat packing:	PCTFE
Handle:	AL
Internal Leakage Allowance:	1x10 ⁻⁹ mbar-l/s He
External Leakage Allowance:	1x10 ⁻⁹ mbar-l/s He
Flow capacity:	1/4" Cv=0.3 3/8" 1/2" Cv=0.65
Weight:	approx. 0.27kg (depending on connections or options)



1/4 Type



1/4 Type (IS option)



1/2 Type



1/2 Type

Diaphragm Valve VDV42UC Series

Dimensions (mm)

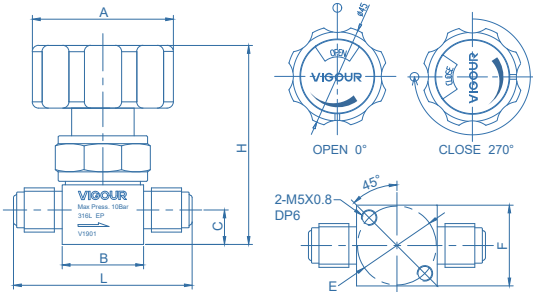

1/4, 3/8, 1/2 manual actuator (VFS male)

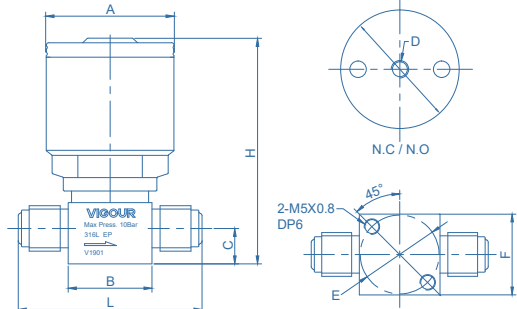

1/4 pneumatic actuator (VFS male)

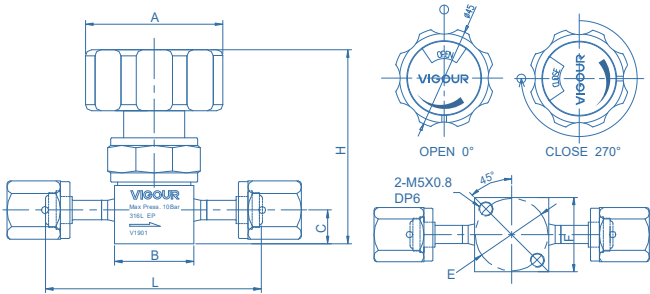

1/4, 1/2 manual actuator (VFS female)

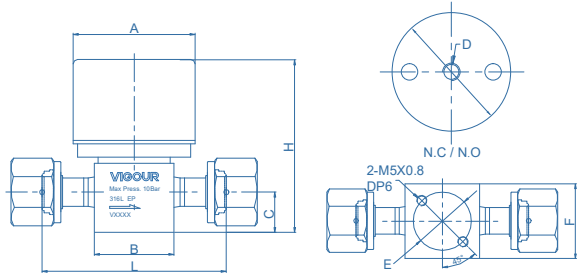

1/2 pneumatic actuator (VFS female)

manual actuator

End Connections	Orifice (mm)	Dimensions (mm)						
		A	B	C	E	F	L	H
1/4" VFS male	4.4	Φ45	26	11	Φ25.4	26	57	69
1/4" VFS female	4.4	Φ45	26	11	Φ25.4	26	71	69
3/8" VFS male	7	Φ45	36	18.2	Φ28	36	77	83
1/2" VFS male	7	Φ45	36	18.2	Φ28	36	77	83
1/2" VFS female	7	Φ45	36	18.2	Φ28	36	83	83
3/4" VFS male	7	Φ45	36	21.5	Φ28	36	122.3	87
3/4" VFS female	7	Φ45	36	21.5	Φ28	36	106.3	87

pneumatic actuator, normally opened / normally closed

End Connections	Actuator	Orifice (mm)	Dimensions (mm)							
			A	B	C	D	E	F	L	H
1/4" VFS male	N.C / N.O	4.4	Φ39.6	26	11	M5x0.8	Φ25.4	26	57	75
1/4" VFS female	N.C / N.O	4.4	Φ39.6	26	11	M5x0.8	Φ25.4	26	71	75
3/8" VFS male	N.C / N.O	7	Φ55	36	18.2	RC 1/8	Φ28	36	77	83
1/2" VFS male	N.C / N.O	7	Φ55	36	18.2	RC 1/8	Φ28	36	77	83
1/2" VFS female	N.C / N.O	7	Φ55	36	18.2	RC 1/8	Φ28	36	83	83

Ordering information

VDV42UCSLV - M - A - MV4 - MV4 - PA - LOTOC - IS - P

Materials

SLV: 316L secondary remelt

Actuator

M: manual actuator
PO: pneumatic actuator, normally opened
PC: pneumatic actuator, normally closed

Flow Circuit Diagram

For details, refer to the flow circuit diagram on page 67.

End Connection

MV4: 1/4" VFS male
FV4: 1/4" VFS female
TW4: 1/4" tube weld
MV6: 1/2" VFS male 3/8" O.D.
FV6: 1/2" VFS female 3/8" O.D.
TW6: 3/8" tube weld
MV8: 1/2" VFS male
FV8: 1/2" VFS female
TW8: 1/2" tube weld

* Other connection standard, consult factory

Valve Seat Option

None: PCTFE (standard)
VS: Vespel®
PA: PFA

Process Specification

P: VS001A
* For details, please refer to the appendix.

Option

None: Standard
IS: Switch Position Indicator

Option

None: standard
LOTO: Closed Position Lock
LOTG: Open Position Lock
LOTOC: Open / Closed Position Lock

* Manual only

Diaphragm Valve VDV52UB Series

Product Feature

- Suitable for ultra-pure, flammable or toxic fluid lines in semiconductor manufacturing equipment and facilities
- Direct diaphragm construction with superior sealing performance, remarkable durability, compactness and particle and dead-space-free performance
- Valve open and closed position is easily visible at a glance
- Excellent gas displacement characteristics
- EP treatment is standard for all wetted surfaces
- Standard seat material is PCTFE, Polyimide / PFA is option

Temperature / Pressure Rating

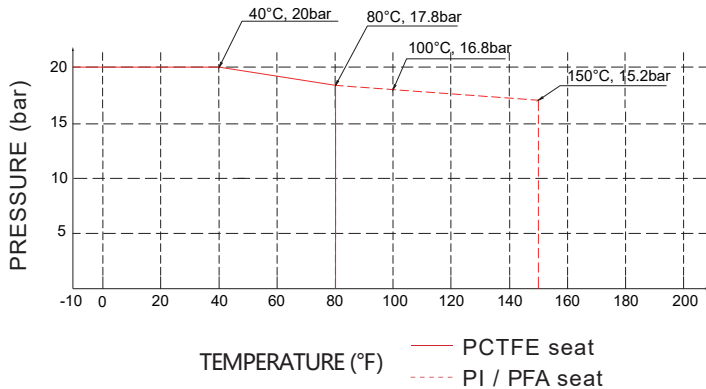

1/4 Type



1/4 Type



1/2 Type



1/2 Type

Technical Data

Max. Working Pressure:	300 psig (20bar)
Actuation Pressure:	58~87psig (4~6bar)
Max. Working Temp.:	14°F ~ 176°F (-10°C ~ 80°C)
Surface finish:	10µin. Ra
Materials	
Body:	see ordering info
Diaphragm:	Elgiloy®
Seat packing:	PCTFE
Handle:	AL
Internal Leakage Allowance:	1x10 ⁻⁹ mbar·l/s He
External Leakage Allowance:	1x10 ⁻⁹ mbar·l/s He
Flow capacity:	1/4" Cv=0.3 3/8" 1/2" Cv=0.65
Weight:	approx. 0.27kg (depending on connections or options)

Diaphragm Valve VDV52UB Series

Dimensions (mm)

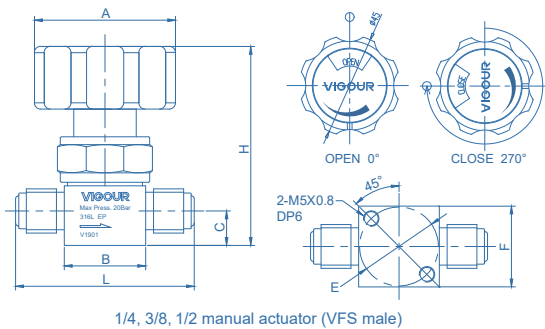

1/4, 3/8, 1/2 manual actuator (VFS male)

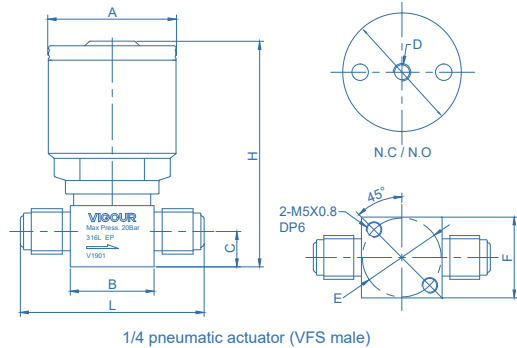

1/4 pneumatic actuator (VFS male)

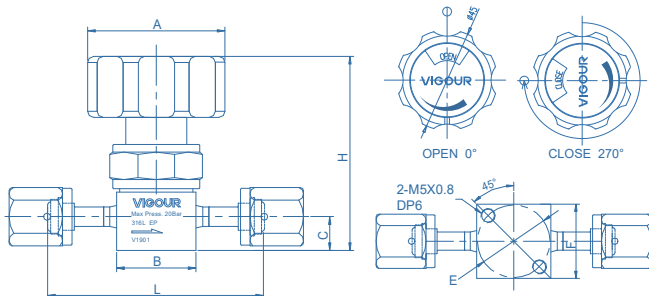

1/4, 1/2 manual actuator (VFS female)

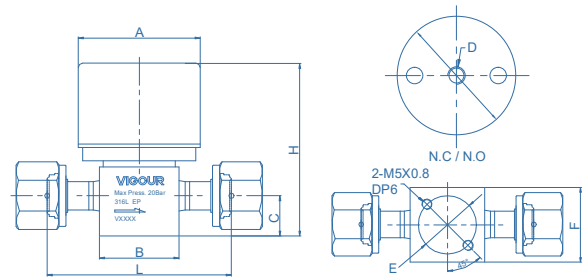

1/2 pneumatic actuator (VFS female)

manual actuator

End Connections	Orifice (mm)	Dimensions (mm)						
		A	B	C	E	F	L	H
1/4" VFS male	4.4	Φ45	26	11	Φ25.4	26	57	64
1/4" VFS female	4.4	Φ45	26	11	Φ25.4	26	71	64
3/8" VFS male	7	Φ45	36	18.2	Φ28	36	77	78
1/2" VFS male	7	Φ45	36	18.2	Φ28	36	77	78
1/2" VFS female	7	Φ45	36	18.2	Φ28	36	83	78

pneumatic actuator, normally opened / normally closed

End Connections	Actuator	Orifice (mm)	Dimensions (mm)							
			A	B	C	D	E	F	L	H
1/4" VFS male	N.C / N.O	4.4	Φ39.6	26	11	M5x0.8	Φ25.4	26	57	70
1/4" VFS female	N.C / N.O	4.4	Φ39.6	26	11	M5x0.8	Φ25.4	26	71	70
3/8" VFS male	N.C / N.O	7	Φ55	36	18.2	RC 1/8	Φ28	36	77	78
1/2" VFS male	N.C / N.O	7	Φ55	36	18.2	RC 1/8	Φ28	36	77	78
1/2" VFS female	N.C / N.O	7	Φ55	36	18.2	RC 1/8	Φ28	36	83	78

Ordering information

VDV52UBS - M - A - MV4 - MV4 - PA - P

Materials

S: 316L

Actuator

M: manual actuator

PO: pneumatic actuator, normally opened

PC: pneumatic actuator, normally closed

Flow Circuit Diagram

For details, refer to the flow circuit diagram on page 67.

End Connection

MV4: 1/4" VFS male

FV4: 1/4" VFS female

TW4: 1/4" tube weld

MV6: 1/2" VFS male 3/8" O.D.

FV6: 1/2" VFS female 3/8" O.D.

TW6: 3/8" tube weld

MV8: 1/2" VFS male

FV8: 1/2" VFS female

TW8: 1/2" tube weld

* Other connection standard, consult factory

Process Specification

none: VS001B

P: VS001A

* For details, please refer to the appendix.

Valve Seat Option

None: PCTFE (standard)

VS: Vespel®

PA: PFA

Diaphragm Valve VDV52UC Series

Product Feature

- Suitable for ultra-pure, flammable or toxic fluid lines in semiconductor manufacturing equipment and facilities
- Direct diaphragm construction with superior sealing performance, remarkable durability, compactness and particle and dead-space-free performance
- Valve open and closed position is easily visible at a glance
- Excellent gas displacement characteristics
- EP treatment is standard for all wetted surfaces
- Standard seat material is PCTFE, Polyimide / PFA is option



1/4 Type



1/4 Type



1/2 Type



1/2 Type

Temperature / Pressure Rating

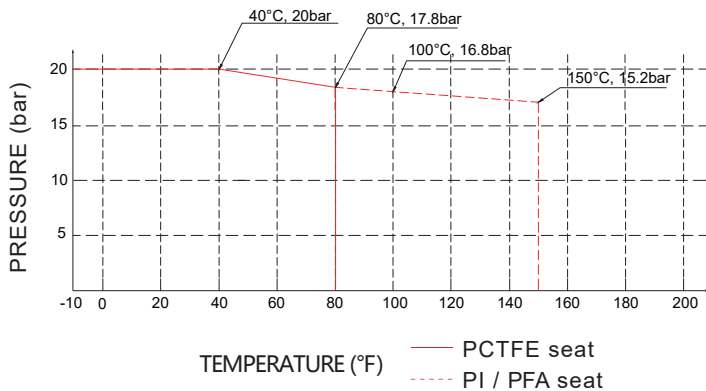

Technical Data

Max. Working Pressure:	300 psig (20bar)
Actuation Pressure:	58~87psig (4~6bar)
Max. Working Temp.:	14°F ~ 176°F (-10°C ~ 80°C)
Surface finish:	7µin. Ra
Materials	
Body:	see ordering info
Diaphragm:	Elgiloy®
Seat packing:	PCTFE
Handle:	AL
Internal Leakage Allowance:	1x10 ⁻⁹ mbar-l/s He
External Leakage Allowance:	1x10 ⁻⁹ mbar-l/s He
Flow capacity:	1/4" Cv=0.3 3/8" 1/2" Cv=0.65
Weight:	approx. 0.27kg (depending on connections or options)

Diaphragm Valve VDV52UC Series

Dimensions (mm)

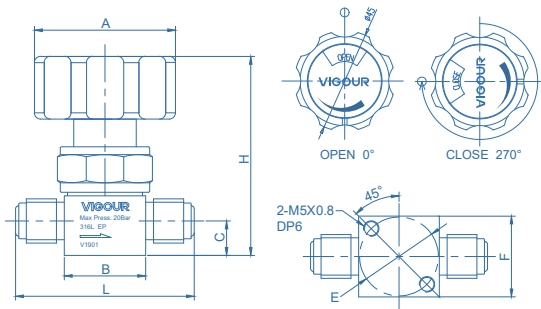

1/4, 3/8, 1/2 manual actuator (VFS male)

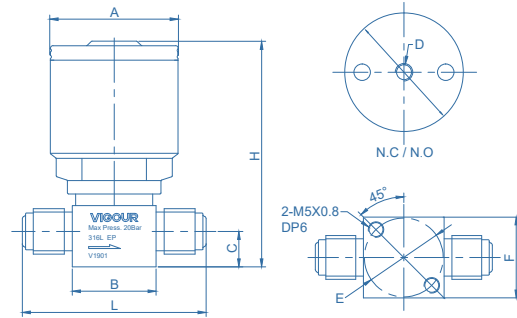

1/4 pneumatic actuator (VFS male)

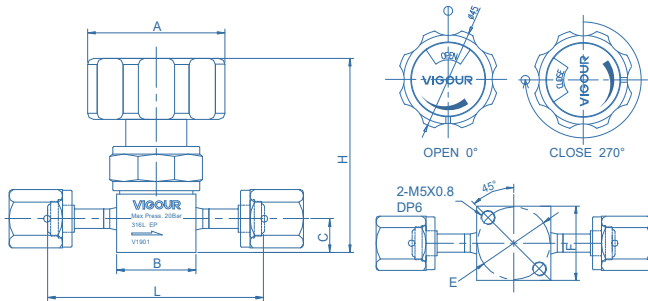

1/4, 1/2 manual actuator (VFS female)

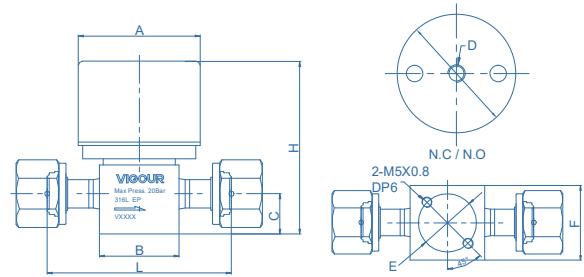

1/2 pneumatic actuator (VFS female)

manual actuator

End Connections	Orifice (mm)	Dimensions (mm)						
		A	B	C	E	F	L	H
1/4" VFS male	4.4	Φ45	26	11	Φ25.4	26	57	64
1/4" VFS female	4.4	Φ45	26	11	Φ25.4	26	71	64
3/8" VFS male	7	Φ45	36	18.2	Φ28	36	77	78
1/2" VFS male	7	Φ45	36	18.2	Φ28	36	77	78
1/2" VFS female	7	Φ45	36	18.2	Φ28	36	83	78

pneumatic actuator, normally opened / normally closed

End Connections	Actuator	Orifice (mm)	Dimensions (mm)							
			A	B	C	D	E	F	L	H
1/4" VFS male	N.C / N.O	4.4	Φ39.6	26	11	M5x0.8	Φ25.4	26	57	70
1/4" VFS female	N.C / N.O	4.4	Φ39.6	26	11	M5x0.8	Φ25.4	26	71	70
3/8" VFS male	N.C / N.O	7	Φ55	36	18.2	RC 1/8	Φ28	36	77	78
1/2" VFS male	N.C / N.O	7	Φ55	36	18.2	RC 1/8	Φ28	36	77	78
1/2" VFS female	N.C / N.O	7	Φ55	36	18.2	RC 1/8	Φ28	36	83	78

Ordering information

VDV52UCSLV - M - A - MV4 - MV4 - PA - P

Materials

SLV: 316L secondary remelt

Actuator

M: manual actuator
PO: pneumatic actuator, normally opened
PC: pneumatic actuator, normally closed

Flow Circuit Diagram

For details, refer to the flow circuit diagram on page 67.

Process Specification

P: VS001A

* For details, please refer to the appendix.

Valve Seat Option

None: PCTFE (standard)
VS: Vespel®
PA: PFA

End Connection

MV4: 1/4" VFS male
FV4: 1/4" VFS female
TW4: 1/4" tube weld
MV6: 1/2" VFS male 3/8" O.D.
FV6: 1/2" VFS female 3/8" O.D.
TW6: 3/8" tube weld
MV8: 1/2" VFS male
FV8: 1/2" VFS female
TW8: 1/2" tube weld

* Other connection standard, consult factory

Diaphragm Valve Flow Circuit Diagram

Ports Diagrammatic Drawing:

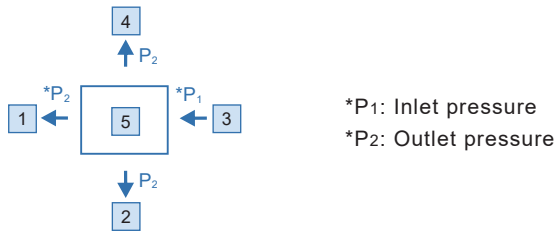

Two ports flow circuit diagram:

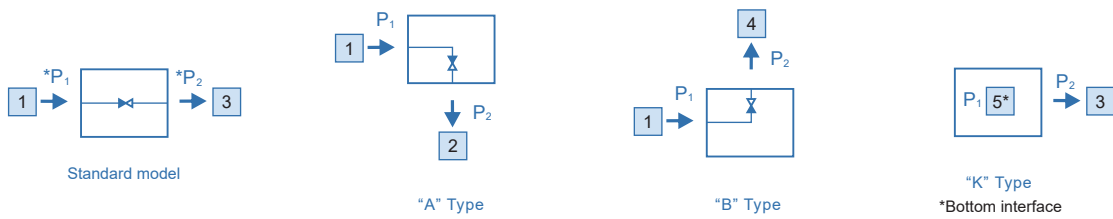

Three ports flow circuit diagram:

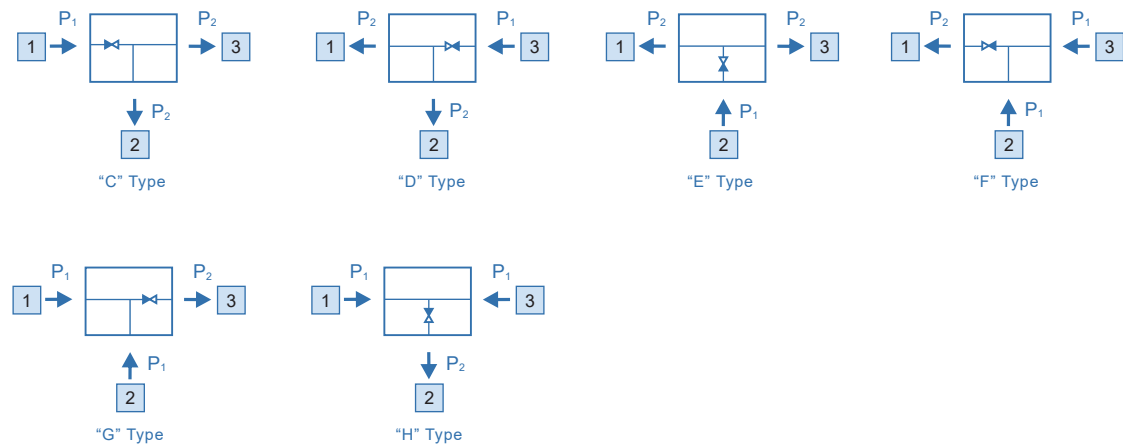

Four ports flow circuit diagram:

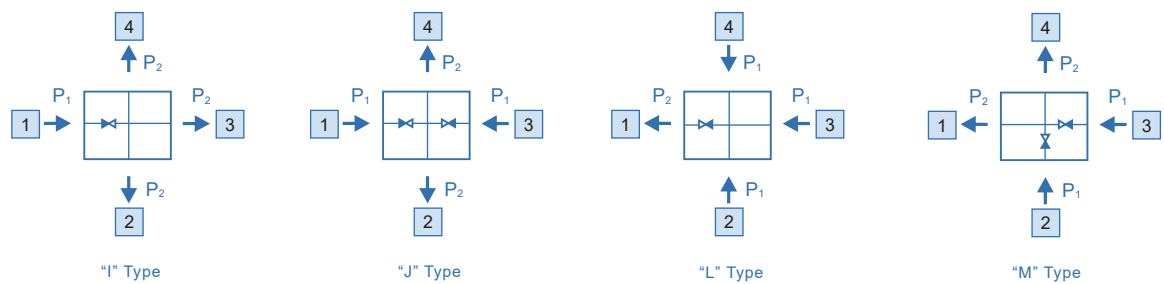

Diaphragm Valve VDV22UB Series

Product Feature

- Suitable for ultra-pure, flammable or toxic fluid lines in semiconductor manufacturing equipment and facilities
- Direct diaphragm construction with superior sealing performance, remarkable durability, compactness and particle and dead-space-free performance
- Valve open and closed position is easily visible at a glance
- EP treatment is standard for all wetted surfaces
- Standard seat material is PCTFE, Polyimide / PFA is option



Temperature / Pressure Rating

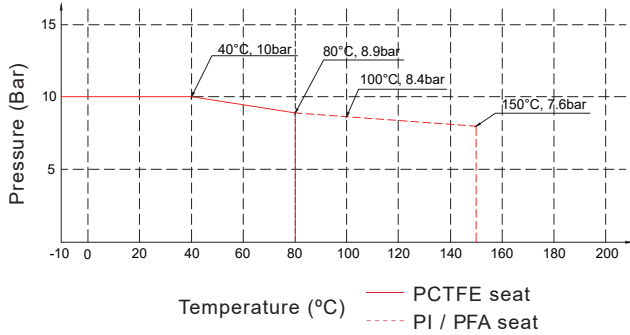

Dimensions (mm)

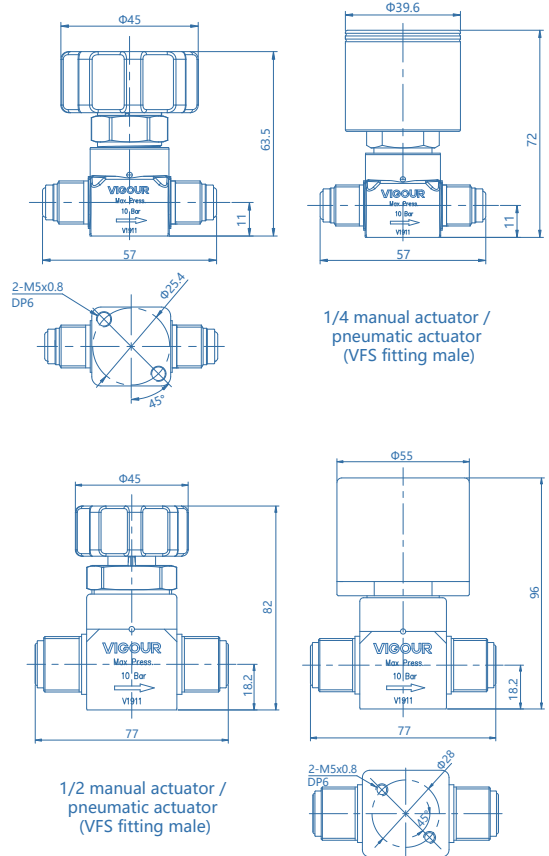

Technical Data

Max. Working Pressure:	150 psig (10bar)
Actuation Pressure:	58~87psig (4~6bar)
Max. Working Temp.:	14°F ~ 176°F (-10°C ~ 80°C)
Surface finish:	10µin. Ra
Materials	
Body:	see ordering info
Diaphragm:	Elgiloy®
Seat packing:	PCTFE
Handle:	AL
Internal Leakage Allowance:	1x10 ⁻⁹ mbar-l/s He
External Leakage Allowance:	1x10 ⁻⁹ mbar-l/s He
Flow capacity:	1/4" Cv=0.3 1/2" Cv=0.65
Weight:	approx. 0.36kg (depending on connections or options)

Ordering information

VDV22UBS - M - MV4 - MV4 - PA - IS - P

Materials

S: 316L

Actuator

M: manual actuator

PO: pneumatic actuator, normally opened

PC: pneumatic actuator, normally closed

Valve Seat Option

None: PCTFE(standard)

VS: Vespel®

PA: PFA

End Connection

MV4: 1/4" VFS fitting male

MV8: 1/2" VFS fitting male

FV4: 1/4" VFS fitting female

FV8: 1/2" VFS fitting female

* Other connection standard, consult factory

Process Specification

None: VS001B

P: VS001A

* For details, please refer to the appendix.

Optional

None: Standard

IS: Switch Position Indicator

Low-pressure Diaphragm Valve Manifold VDV36UB Series

Product Feature

- Excellent degassing characteristics is achieved through minimized flow paths by combining 2 of VDV32 diaphragm valves together in one valve body.
- Fewer welds over standard valve alignments
- Reduces space requirements
- Compact tubing arrangement
- Dead space free configuration



Dimensions (mm)

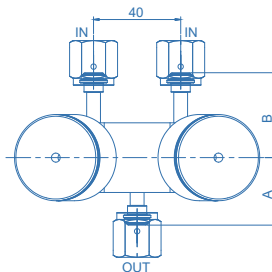
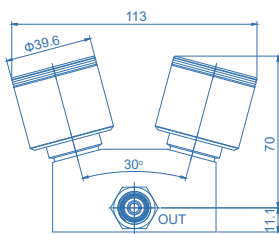

End Connections	Dimensions (mm)	
	A	B
VFS Female	31	39
VFS Male	46.3	46.3

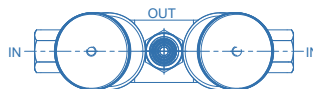
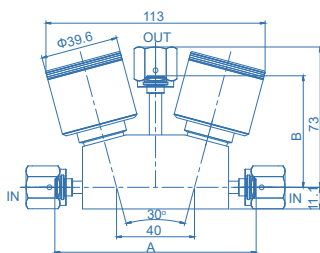

End Connections	Dimensions (mm)	
	A	B
VFS Female	103.4	57.3
VFS Male	139.6	70

Technical Data

Max. Working Pressure:	150 psig (10bar)
Actuation Pressure:	58~87psig (4~6bar)
Max. Working Temp.:	14°F ~ 104°F (-10°C ~ 40°C)
Surface finish:	10µin. Ra
Materials	
Body:	see ordering info
Diaphragm:	Elgiloy®
Seat packing:	PCTFE
Handle:	AL
Internal Leakage Allowance:	1x10 ⁻⁹ mbar·l/s He
External Leakage Allowance:	1x10 ⁻⁹ mbar·l/s He
Flow capacity:	Cv=0.3
Weight:	approx. 1.36kg (depending on connections or options)

Low-pressure Diaphragm Valve Manifold VDV36UB Series

Ordering information

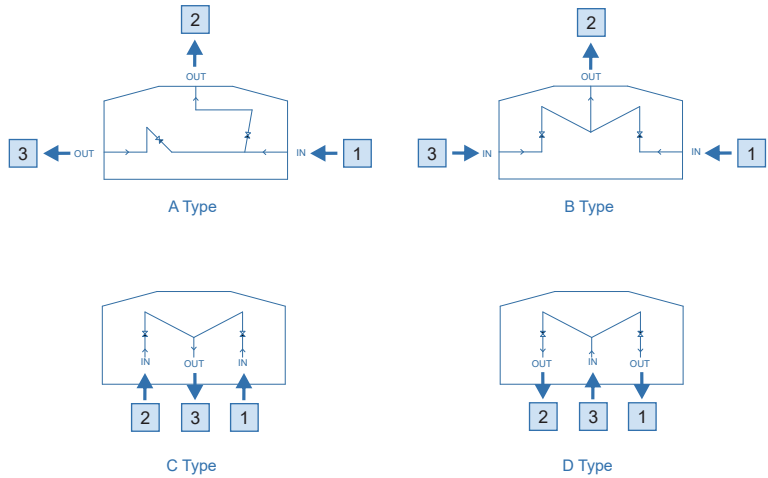

Inlet/Outlet Connection

MV4: 1/4" VFS male
 FV4: 1/4" VFS female
 TW4: 1/4" tube weld

* Other connection standard, consult factory.

Port Selection

VDV36UBS - A - PC - PC - 1 - 2 - 3 - P

Materials

S: 316L

Flow Rate

A: A Type
 B: B Type
 C: C Type
 D: D Type

Valve1 Actuator

M: manual actuator
 PO: pneumatic actuator, normally opened
 PC: pneumatic actuator, normally closed

Process Specification

None: VS001B
 P: VS001A

* For details, please refer to the appendix.

Valve2 Actuator*

M: manual actuator
 PO: pneumatic actuator, normally opened
 PC: pneumatic actuator, normally closed

* When the actuators are the same there will be one symbol.

Ordering Example

VDV36UBS - C - PC - PC - FV4 - FV4 - FV4

1 - 2 - 3



Low-pressure Diaphragm Valve Manifold VDV36UC Series

Product Feature

- Excellent degassing characteristics is achieved through minimized flow paths by combining 2 of VDV32 diaphragm valves together in one valve body.
- Fewer welds over standard valve alignments
- Reduces space requirements
- Compact tubing arrangement
- Dead space free configuration



Dimensions (mm)

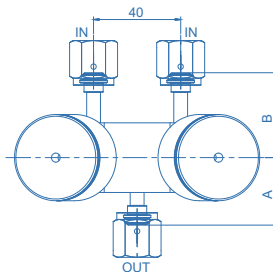
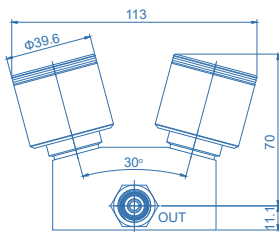

End Connections	Dimensions (mm)	
	A	B
VFS Female	31	39
VFS Male	46.3	46.3

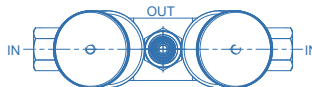
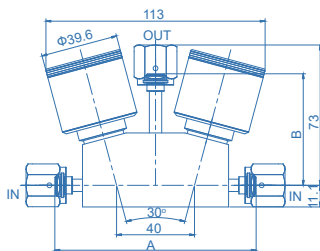

End Connections	Dimensions (mm)	
	A	B
VFS Female	103.4	57.3
VFS Male	139.6	70

Technical Data

Max. Working Pressure:	150 psig (10bar)
Actuation Pressure:	58~87psig (4~6bar)
Max. Working Temp.:	14°F ~ 104°F (-10°C ~ 40°C)
Surface finish:	7μin. Ra
Materials	
Body:	see ordering info
Diaphragm:	Elgiloy®
Seat packing:	PCTFE
Handle:	AL
Internal Leakage Allowance:	1x10 ⁻⁹ mbar·l/s He
External Leakage Allowance:	1x10 ⁻⁹ mbar·l/s He
Flow capacity:	Cv=0.1
Weight:	approx. 1.36kg (depending on connections or options)

Low-pressure Diaphragm Valve Manifold VDV36UC Series

Ordering information

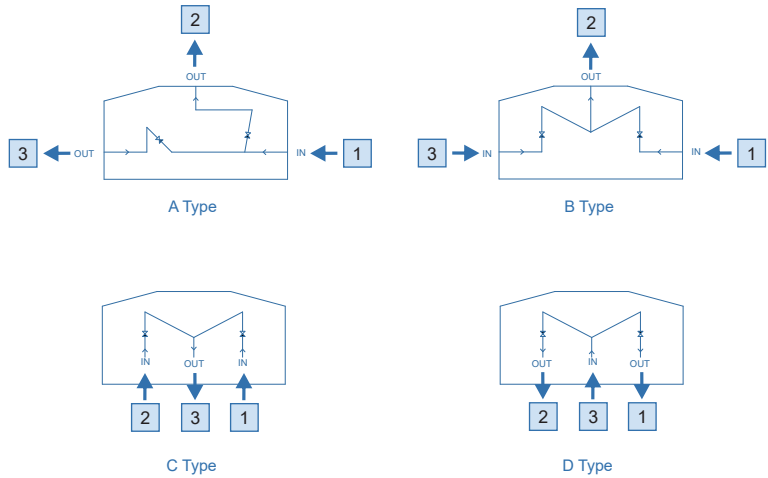

Inlet/Outlet Connection

MV4: 1/4" VFS male
 FV4: 1/4" VFS female
 TW4: 1/4" tube weld

* Other connection standard, consult factory.

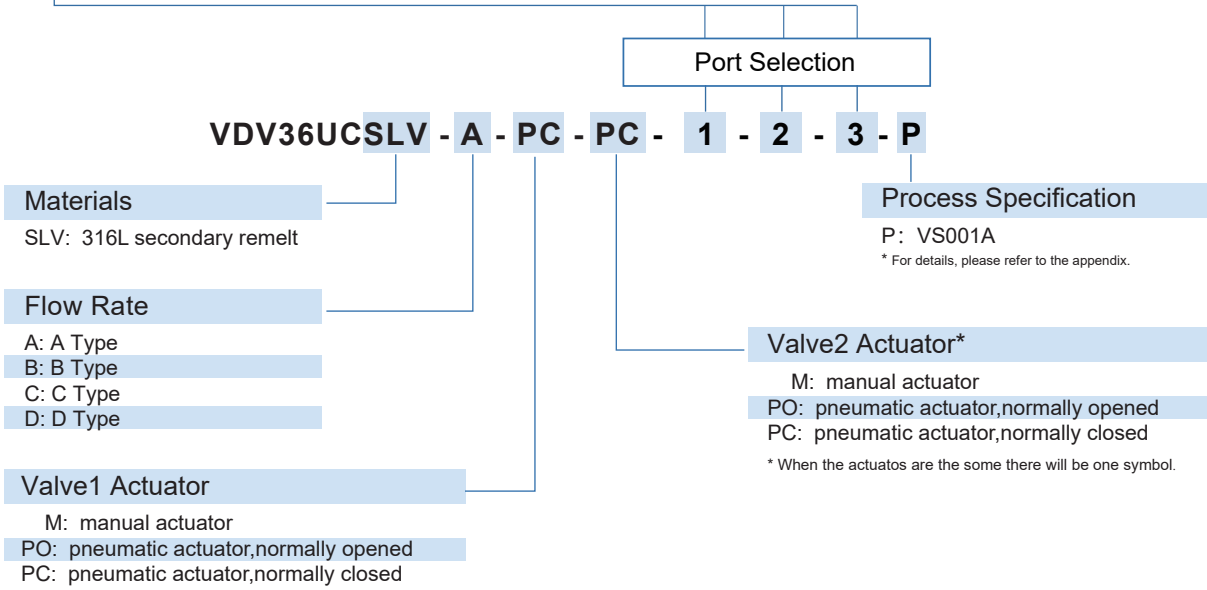

Ordering Example

VDV36UCSLV - C - PC - PC - FV4 - FV4 - FV4
 1 - 2 - 3



High-pressure Diaphragm Valve Manifold VDV46UB Series

Product Feature

- Excellent degassing characteristics is achieved through minimized flow paths by combining 2 of VDV33 diaphragm valves together in one valve body.
- Fewer welds over standard valve alignments
- Reduces space requirements
- Compact tubing arrangement
- Dead space free configuration



Dimensions (mm)

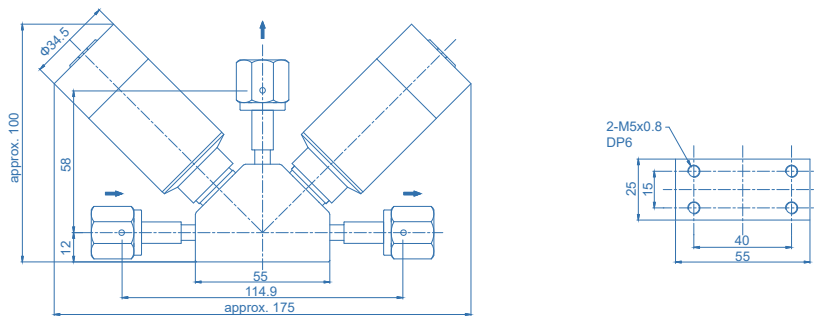

Technical Data

Max. Working Pressure:	3000 psig (200bar)
Actuation Pressure:	58~87psig (4~6bar)
Max. Working Temp.:	14°F ~ 104°F (-10°C ~ 40°C)
Surface finish:	10µin. Ra
Materials	
Body:	see ordering info
Diaphragm:	Elgiloy®
Seat packing:	PCTFE
Handle:	AL
Internal Leakage Allowance:	1x10 ⁻⁹ mbar·l/s He
External Leakage Allowance:	1x10 ⁻⁹ mbar·l/s He
Flow capacity:	Cv=0.1
Weight:	approx. 1.36kg (depending on connections or options)

High-pressure Diaphragm Valve Manifold VDV46UB Series

Ordering information

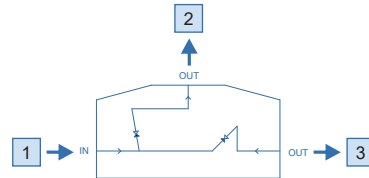

Inlet/Outlet Connection

MV4: 1/4" VFS male
 FV4: 1/4" VFS female
 TW4: 1/4" tube weld

* Other connection standard, consult factory.

Port Selection

VDV46UBS - PC - PC - 1 - 2 - 3 - P

Materials

S: 316L

Process Specification

None: VS001B
 P: VS001A

* For details, please refer to the appendix.

Valve1 Actuator

PC: pneumatic actuator, normally closed

Valve2 Actuator*

PC: pneumatic actuator, normally closed

* When the actuators are the same there will be one symbol.

Ordering Example

VDV46UBS - PC - PC - FV4 - FV4 - FV4
 1 - 2 - 3



High-pressure Diaphragm Valve Manifold VDV46UC Series

Product Feature

- Excellent degassing characteristics is achieved through minimized flow paths by combining 2 of VDV33 diaphragm valves together in one valve body.
- Fewer welds over standard valve alignments
- Reduces space requirements
- Compact tubing arrangement
- Dead space free configuration



Dimensions (mm)

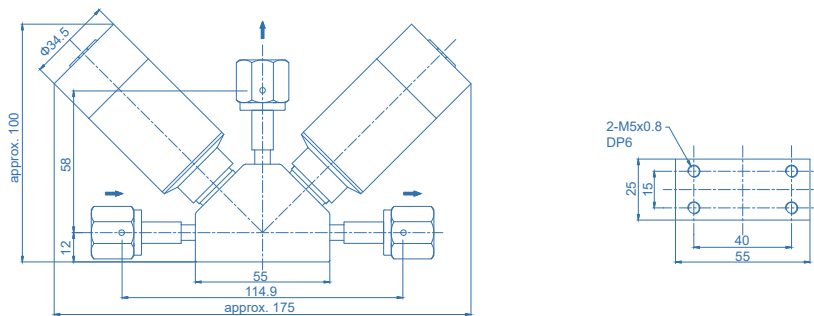

Technical Data

Max. Working Pressure:	3000 psig (200bar)
Actuation Pressure:	58~87psig (4~6bar)
Max. Working Temp.:	14°F ~ 104°F (-10°C ~ 40°C)
Surface finish:	7μin. Ra
Materials	
Body:	see ordering info
Diaphragm:	Elgiloy®
Seat packing:	PCTFE
Handle:	AL
Internal Leakage Allowance:	1x10 ⁻⁹ mbar·l/s He
External Leakage Allowance:	1x10 ⁻⁹ mbar·l/s He
Flow capacity:	Cv=0.1
Weight:	approx. 1.36kg (depending on connections or options)

High-pressure Diaphragm Valve Manifold VDV46UC Series

Ordering information

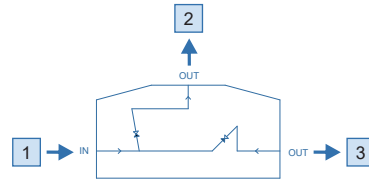

Inlet/Outlet Connection

MV4: 1/4" VFS male
 FV4: 1/4" VFS female
 TW4: 1/4" tube weld

* Other connection standard, consult factory.

Port Selection

VDV46UCSLV - PC - PC - 1 - 2 - 3 - P

Materials

SLV: 316L secondary remelt

Process Specification

P: VS001A

* For details, please refer to the appendix.

Valve1 Actuator

PC: pneumatic actuator, normally closed

Valve2 Actuator*

PC: pneumatic actuator, normally closed

* When the actuators are the same there will be one symbol.

Ordering Example

VDV46UCSLV - PC - PC - FV4 - FV4 - FV4
 1 - 2 - 3



Ultra High Purity Purging Block

VDV48UB Series

Product Feature

- Continuous gas purity during cylinder changeover
- Easy to operate (manual/pneumatic operation available)
- Process gas is isolated from the atmosphere
- Compact design
- No dead spaces inside
- Suitable for ultra-high purity gases



Dimensions (mm)

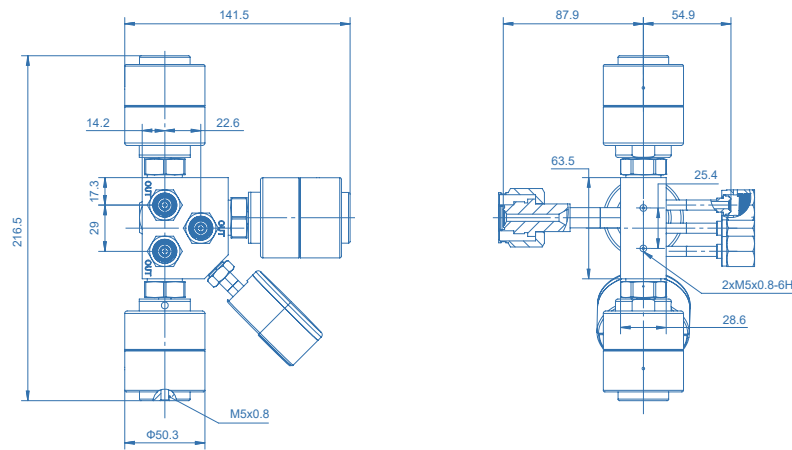

Technical Data

Max. Working Pressure:	3000 psig (200 bar)
Actuation Pressure:	70~110psig (5~8bar)
Max. Working Temp.:	40°F ~ 160°F (-40°C ~ 71°C)
Surface finish:	10µin. Ra
Materials	
Body:	see ordering info
Diaphragm:	Elgiloy®
Seat packing:	PCTFE
Handle:	AL
Internal Leakage Allowance:	<1x10 ⁻⁹ mbar·l/s He
External Leakage Allowance:	<1x10 ⁻⁹ mbar·l/s He
Flow capacity:	Cv=0.1
Weight:	approx. 2.9kg (depending on connections or options)

Ultra High Purity Purging Block VDV48UB Series

Ordering information

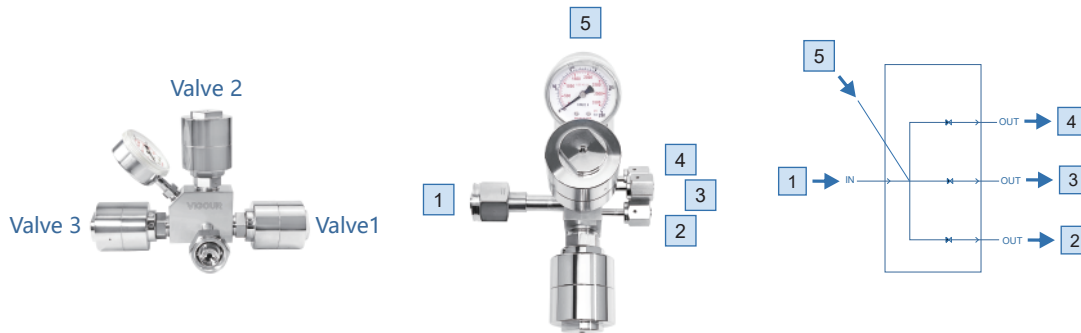

Inlet/Outlet Connection

MV4: 1/4" VFS male
 FV4: 1/4" VFS female
 TW4: 1/4" tube weld

* Other connection standard, consult factory.

Port Selection

VDV48UBS - PC - PC - PC - 1 - 2 - 3 - 4 - 5 - P

Materials

S: 316L

Valve1 Actuator

M: manual actuator
 PC: pneumatic actuator, normally closed

Valve2 Actuator

M: manual actuator
 PC: pneumatic actuator, normally closed

Valve3 Actuator

M: manual actuator
 PC: pneumatic actuator, normally closed

Process Specification

None: VS001B
 P: VS001A

* For details, please refer to the appendix.

End Connection

None: gauge (1/4" VFS fitting)
 IP: gauge (IFV4 fitting)
 PT: Pressure transducer

End Connection

CGA: USA
 DIN: Germany
 BSP: British
 GB: China
 JIS: Japan
 UNI: Italy
 NF: French

Ordering Example

VDV48UBS - PC - PC - PC - CGA632 - FV4 - FV4 - FV4
 1 - 2 - 3 - 4



Ultra High Purity Purging Block VDV48UC Series

Product Feature

- Continuous gas purity during cylinder changeover
- Easy to operate (manual/pneumatic operation available)
- Process gas is isolated from the atmosphere
- Compact design
- No dead spaces inside
- Suitable for ultra-high purity gases



Dimensions (mm)

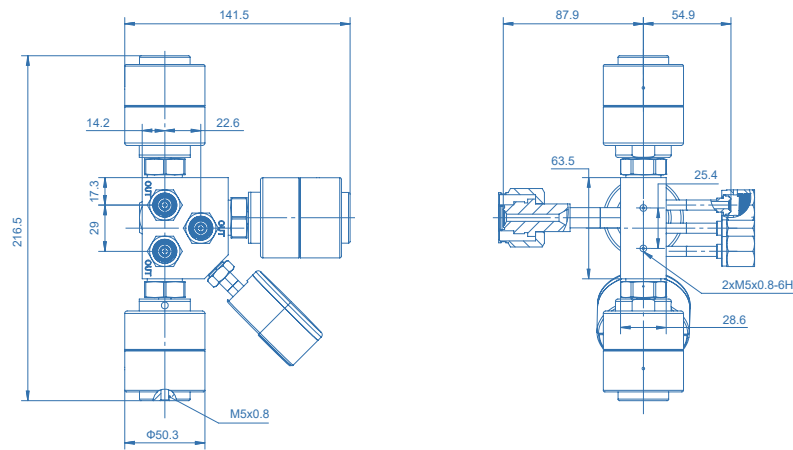

Technical Data

Max. Working Pressure:	3000 psig (200 bar)
Actuation Pressure:	70~110psig (5~8bar)
Max. Working Temp.:	40°F ~ 160°F (-40°C ~ 71°C)
Surface finish:	10µin. Ra
Materials	
Body:	see ordering info
Diaphragm:	Elgiloy®
Seat packing:	PCTFE
Handle:	AL
Internal Leakage Allowance:	<1x10 ⁻⁹ mbar·l/s He
External Leakage Allowance:	<1x10 ⁻⁹ mbar·l/s He
Flow capacity:	Cv=0.1
Weight:	approx. 2.9kg (depending on connections or options)

Ultra High Purity Purging Block VDV48UC Series

Ordering information

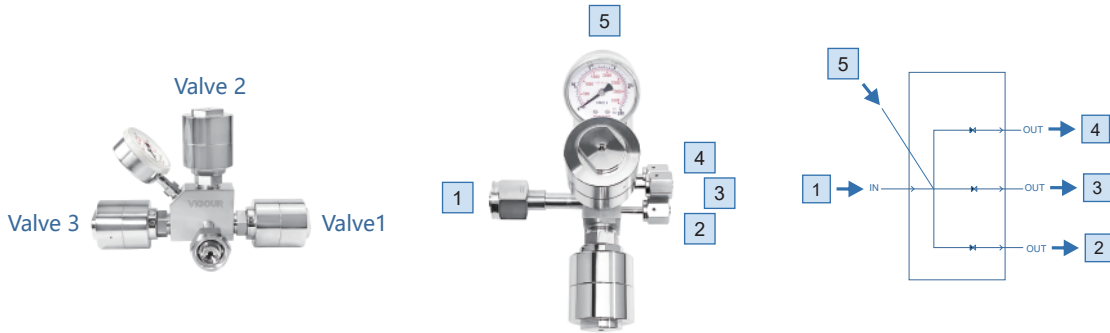

Inlet/Outlet Connection

- MV4: 1/4" VFS male
- FV4: 1/4" VFS female
- TW4: 1/4" tube weld

* Other connection standard, consult factory.

Port Selection

VDV48UCSLV - PC - PC - PC - 1 - 2 - 3 - 4 - 5 - P

Materials

S: 316L secondary remelt

Valve1 Actuator

- M: manual actuator
- PC: pneumatic actuator, normally closed

Valve2 Actuator

- M: manual actuator
- PC: pneumatic actuator, normally closed

Valve3 Actuator

- M: manual actuator
- PC: pneumatic actuator, normally closed

Process Specification

P: VS001A
* For details, please refer to the appendix.

End Connection

- None: gauge (1/4" VFS fitting)
- IP: gauge (IFV4 fitting)
- PT: Pressure transducer

End Connection

- CGA: USA
- DIN: Germany
- BSP: British
- GB: China
- JIS: Japan
- UNI: Italy
- NF: French

Ordering Example

VDV48UCS - PC - PC - PC - CGA632 - FV4 - FV4 - FV4 - P

1 - 2 - 3 - 4



Diaphragm Valve VDV37UB Series

Product Feature

- Suitable for ultra-pure, flammable or toxic fluid lines in semiconductor manufacturing equipment and facilities
- Direct diaphragm construction with superior sealing performance, remarkable durability, compactness and particle free performance
- Valve open and closed position is easily visible at a glance
- Excellent gas displacement characteristics
- EP treatment is standard for all wetted surfaces
- Standard seat material is PCTFE, Polyimide is option



1/2" pneumatic actuator



1/2" manual actuator



3/4" manual actuator (Lockable)

Temperature / Pressure Rating

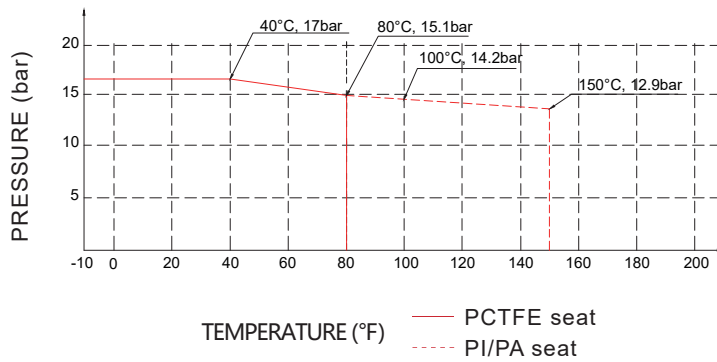

Technical Data

Max. Working Pressure:	Manual 300 psig (20bar) / Pneumatic 250 psig (17bar)
Actuation Pressure:	80~100 psig (5.5~6.8bar)
Max. Working Temp.:	-40°F ~ 159°F (-40°C ~ 71°C)
Surface finish:	10µin. Ra
Materials	
Body:	see ordering info
Diaphragm:	Elgiloy®
Seat packing:	PCTFE
Handle:	AL
Internal Leakage Allowance:	1x10 ⁻⁹ mbar·l/s He
External Leakage Allowance:	1x10 ⁻⁹ mbar·l/s He
Flow capacity:	Cv=2.8
Weight:	approx. 1.36kg (depending on connections or options)

Diaphragm Valve VDV37UB Series

Dimensions (mm)

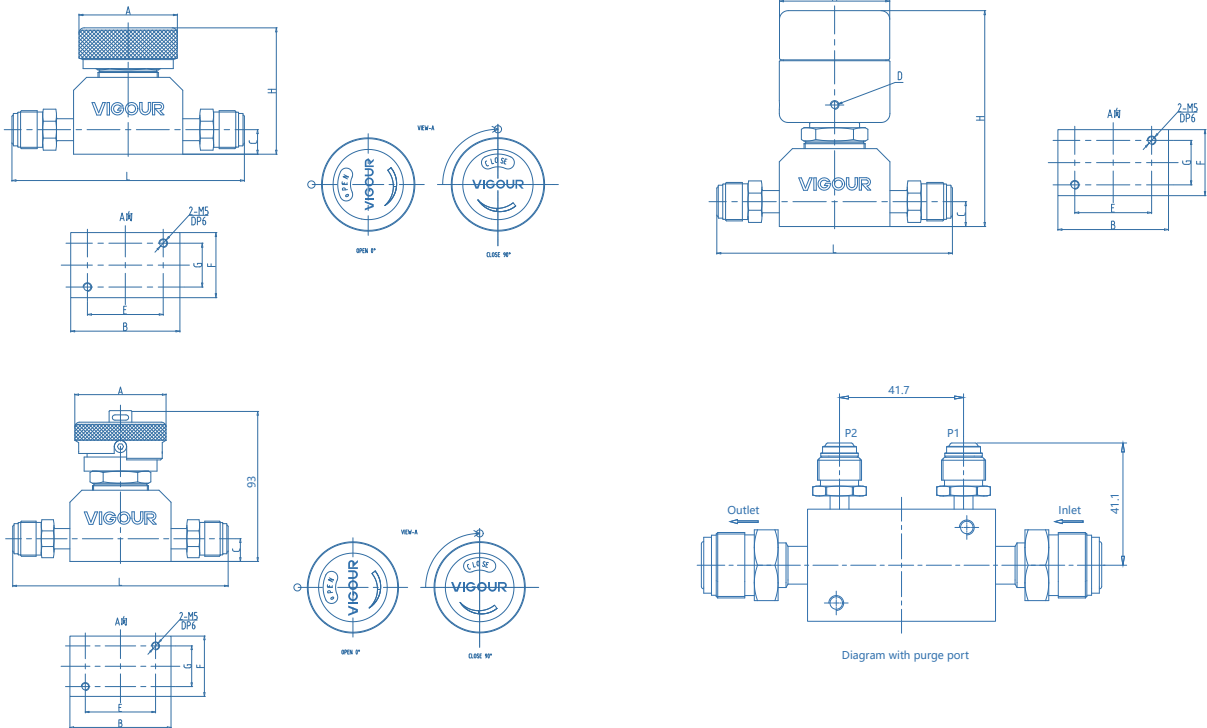

manual actuator

End Connections	Orifice (mm)	Dimensions (mm)								
		A	B	C	E	F	G	L	H	
1/2" VFS male	10.2	Φ57	63.2	14.2	43.9	37.7	25.4	134.6	72.4	
1/2" VFS female	10.2	Φ57	63.2	14.2	43.9	37.7	25.4	134.6	72.4	
1/2" Tube Weld	10.2	Φ57	63.2	14.2	43.9	37.7	25.4	216.0	72.4	
3/4" VFS male	12.8	Φ57	63.2	14.2	43.9	37.7	25.4	162.6	72.4	
3/4" VFS female	12.8	Φ57	63.2	14.2	43.9	37.7	25.4	162.6	72.4	
3/4" Tube Weld	12.8	Φ57	63.2	14.2	43.9	37.7	25.4	216.0	72.4	
3/8" Tube Weld	10.2	Φ57	63.2	14.2	43.9	37.7	25.4	216.0	72.4	

pneumatic actuator (normally closed)

End Connections	Orifice (mm)	Dimensions (mm)									
		A	B	C	D	E	F	G	L	H	
1/2" VFS male	10.2	Φ63	63.2	14.2	M5x0.8	43.9	37.7	25.4	134.6	125	
1/2" VFS female	10.2	Φ63	63.2	14.2	M5x0.8	43.9	37.7	25.4	134.6	125	
1/2" Tube Weld	10.2	Φ63	63.2	14.2	M5x0.8	43.9	37.7	25.4	216.0	125	
3/4" VFS male	12.8	Φ63	63.2	14.2	M5x0.8	43.9	37.7	25.4	162.6	125	
3/4" VFS female	12.8	Φ63	63.2	14.2	M5x0.8	43.9	37.7	25.4	162.6	125	
3/4" Tube Weld	12.8	Φ63	63.2	14.2	M5x0.8	43.9	37.7	25.4	216.0	125	
3/8" Tube Weld	10.2	Φ63	63.2	14.2	M5x0.8	43.9	37.7	25.4	216.0	125	

Ordering Information

VDV37UBS - M - MV8 - MV8 - P1 - P2 - VS - LO - IS - P

Materials

S: 316L

Actuator

M: manual actuator

PC: pneumatic actuator (normally closed)

End Connection

TW6: 3/8" Tube weld

FV8: 1/2" VFS female

MV8: 1/2" VFS male

TW8: 1/2" Tube weld

FV12: 3/4" VFS female

MV12: 3/4" VFS male

TW12: 3/4" Tube weld

* Other connection standard, consult factory

Inlet Purge Connection

None: No inlet purge

P1: 1/4" inlet purge

Outlet Purge Connection

None: No outlet purge

P2: 1/4" outlet purge

Process Specification

None: VS001B

P: VS001A

* For details, please refer to the appendix.

Optional

None: Standard

IS: Switch Position Indicator

Optional

None: Round Knob

LO: Round Knob

Pull, then turn to open

lock out / tag out

Valve Seat Option

None: PCTFE (standard)

VS: Vespel®

Diaphragm Valve VDV37UC Series

Product Feature

- Suitable for ultra-pure, flammable or toxic fluid lines in semiconductor manufacturing equipment and facilities
- Direct diaphragm construction with superior sealing performance, remarkable durability, compactness and particle free performance
- Valve open and closed position is easily visible at a glance
- Excellent gas displacement characteristics
- EP treatment is standard for all wetted surfaces
- Standard seat material is PCTFE, Polyimide is option

Temperature / Pressure Rating

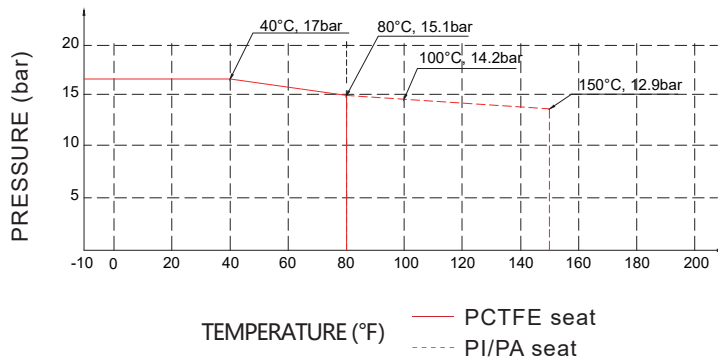

1/2" pneumatic actuator



1/2" manual actuator



3/4" manual actuator (Lockable)

Technical Data

Max. Working Pressure:	Manual 300 psig (20bar) / Pneumatic 250 psig (17bar)
Actuation Pressure:	80~100 psig (5.5~6.8bar)
Max. Working Temp.:	-40°F ~ 159°F (-40°C ~ 71°C)
Surface finish:	7µin. Ra
Materials	
Body:	see ordering info
Diaphragm:	Elgiloy®
Seat packing:	PCTFE
Handle:	AL
Internal Leakage Allowance:	1x10 ⁻⁹ mbar·l/s He
External Leakage Allowance:	1x10 ⁻⁹ mbar·l/s He
Flow capacity:	Cv=2.8
Weight:	approx. 1.36kg (depending on connections or options)

Diaphragm Valve VDV37UC Series

Dimensions (mm)

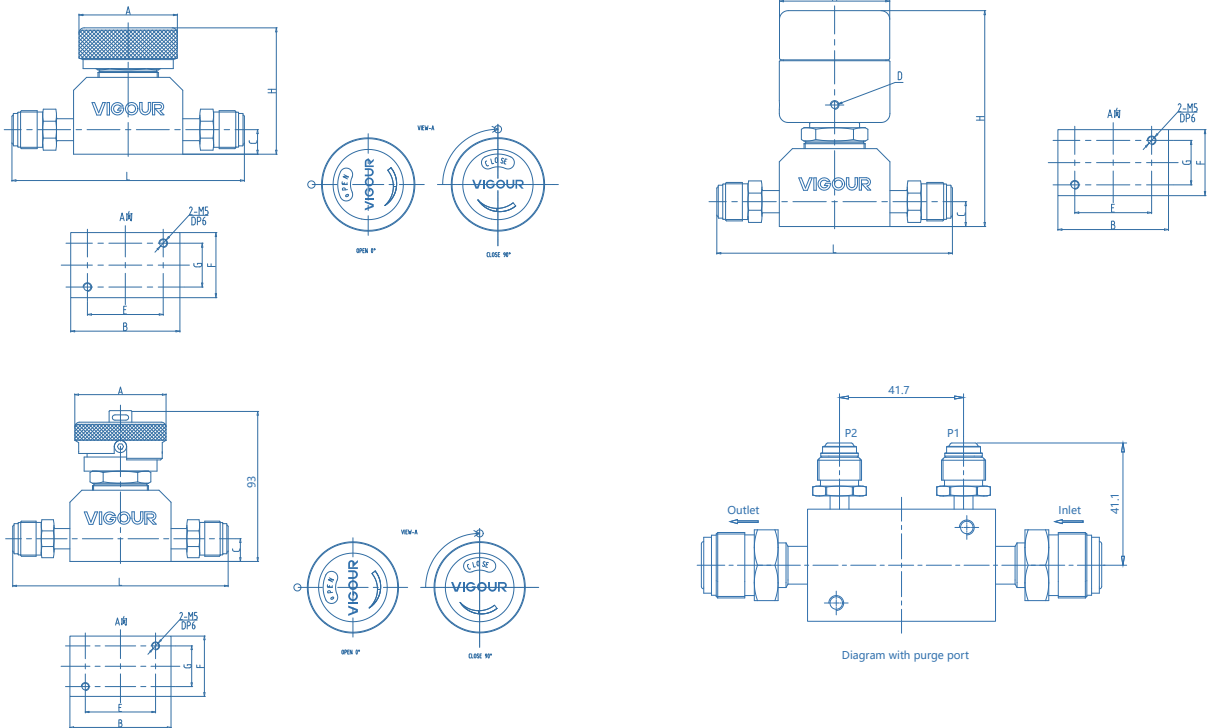

manual actuator

End Connections	Orifice (mm)	Dimensions (mm)								
		A	B	C	E	F	G	L	H	
1/2" VFS male	10.2	Φ57	63.2	14.2	43.9	37.7	25.4	134.6	72.4	
1/2" VFS female	10.2	Φ57	63.2	14.2	43.9	37.7	25.4	134.6	72.4	
1/2" Tube Weld	10.2	Φ57	63.2	14.2	43.9	37.7	25.4	216.0	72.4	
3/4" VFS male	12.8	Φ57	63.2	14.2	43.9	37.7	25.4	162.6	72.4	
3/4" VFS female	12.8	Φ57	63.2	14.2	43.9	37.7	25.4	162.6	72.4	
3/4" Tube Weld	12.8	Φ57	63.2	14.2	43.9	37.7	25.4	216.0	72.4	
3/8" Tube Weld	10.2	Φ57	63.2	14.2	43.9	37.7	25.4	216.0	72.4	

pneumatic actuator (normally closed)

End Connections	Orifice (mm)	Dimensions (mm)								
		A	B	C	D	E	F	G	L	H
1/2" VFS male	10.2	Φ63	63.2	14.2	M5x0.8	43.9	37.7	25.4	134.6	125
1/2" VFS female	10.2	Φ63	63.2	14.2	M5x0.8	43.9	37.7	25.4	134.6	125
1/2" Tube Weld	10.2	Φ63	63.2	14.2	M5x0.8	43.9	37.7	25.4	216.0	125
3/4" VFS male	12.8	Φ63	63.2	14.2	M5x0.8	43.9	37.7	25.4	162.6	125
3/4" VFS female	12.8	Φ63	63.2	14.2	M5x0.8	43.9	37.7	25.4	162.6	125
3/4" Tube Weld	12.8	Φ63	63.2	14.2	M5x0.8	43.9	37.7	25.4	216.0	125
3/8" Tube Weld	10.2	Φ63	63.2	14.2	M5x0.8	43.9	37.7	25.4	216.0	125

Ordering Information

VDV37UCSLV - M - MV8 - MV8 - P1 - P2 - VS - LO - IS - P

Materials

SLV: 316L secondary remelt

Actuator

M: manual actuator

PC: pneumatic actuator (normally closed)

End Connection

TW6: 3/8" Tube weld

FV8: 1/2" VFS female

MV8: 1/2" VFS male

TW8: 1/2" Tube weld

FV12: 3/4" VFS female

MV12: 3/4" VFS male

TW12: 3/4" Tube weld

* Other connection standard, consult factory

Inlet Purge Connection

None: No inlet purge

P1: 1/4" inlet purge

Outlet Purge Connection

None: No outlet purge

P2: 1/4" outlet purge

Process Specification

P: VS001A

* For details, please refer to the appendix.

Optional

None: Standard

IS: Switch Position Indicator

Optional

None: Round Knob

LO: Round Knob

Pull, then turn to open

lock out / tag out

Valve Seat Option

None: PCTFE (standard)

VS: Vespel®

Diaphragm Valve VDV38UB Series

Product Feature

- Suitable for ultra-pure, flammable or toxic fluid lines in semiconductor manufacturing equipment and facilities
- Direct diaphragm construction with superior sealing performance, remarkable durability, compactness and particle free performance
- Valve open and closed position is easily visible at a glance
- Excellent gas displacement characteristics
- EP treatment is standard for all wetted surfaces
- Standard seat material is PCTFE, Polyimide is option



1/2" pneumatic actuator



1/2" manual actuator



1/2" Right-angle handle



3/4" manual actuator (Lockable)

Temperature / Pressure Rating

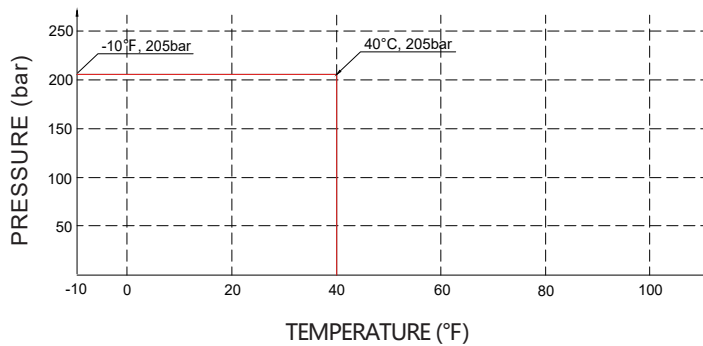

Technical Data

Max. Working Pressure:	3000 psig (200bar) / 1300 psig (90bar)
Actuation Pressure:	70~110 psig (5~8bar)
Max. Working Temp.:	-40°F ~ 150°F (-40°C ~ 65°C)
Surface finish:	10µin. Ra
Materials	
Body:	see ordering info
Diaphragm:	Elgiloy®
Seat packing:	PCTFE
Handle:	AL
Internal Leakage Allowance:	1x10 ⁻⁹ mbar·l/s He
External Leakage Allowance:	1x10 ⁻⁹ mbar·l/s He
Flow capacity:	manual actuator Cv=1.0 pneumatic actuator Cv=1.0 (90bar) / Cv=0.7 (206 bar)
Weight:	approx. 1.36kg (depending on connections or options)

Dimensions (mm)

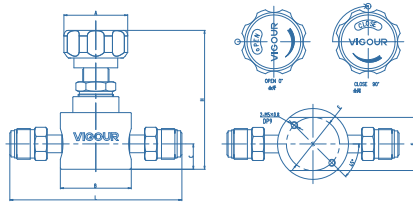

manual actuator (90 bar)

End Connections	Orifice (mm)	Dimensions (mm)							
		A	B	C	E	F	L	H	
1/4" VFS male	4.4	Φ47.8	50.8	18.2	Φ38.1	38	101.6	100	
1/4" VFS female	4.4	Φ47.8	50.8	18.2	Φ38.1	38	101.6	100	
1/2" VFS male	7	Φ47.8	50.8	18.2	Φ38.1	38	123.2	100	
1/2" VFS female	7	Φ47.8	50.8	18.2	Φ38.1	38	123.2	100	
3/4" VFS male	7	Φ47.8	50.8	18.2	Φ38.1	38	177.8	100	
3/4" VFS female	7	Φ47.8	50.8	18.2	Φ38.1	38	177.8	100	
3/8" Tube weld	7	Φ47.8	50.8	18.2	Φ38.1	38	69.8	100	
1/2" Tube weld	7	Φ47.8	50.8	18.2	Φ38.1	38	90.8	100	
3/4" Tube weld	7	Φ47.8	50.8	18.2	Φ38.1	38	165.2	100	

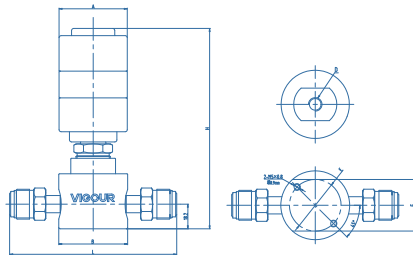

pneumatic actuator (normally closed 90 bar)

End Connections	Orifice (mm)	Dimensions (mm)								
		A	B	C	D	E	F	L	H	
1/4" VFS male	4.4	Φ50.3	50.8	18.2	M5x0.8	Φ38.1	38	101.6	148	
1/4" VFS female	4.4	Φ50.3	50.8	18.2	M5x0.8	Φ38.1	38	101.6	148	
1/2" VFS male	7	Φ50.3	50.8	18.2	M5x0.8	Φ38.1	38	123.2	148	
1/2" VFS female	7	Φ50.3	50.8	18.2	M5x0.8	Φ38.1	38	123.2	148	
3/4" VFS male	7	Φ50.3	50.8	18.2	M5x0.8	Φ38.1	38	177.8	148	
3/4" VFS female	7	Φ50.3	50.8	18.2	M5x0.8	Φ38.1	38	177.8	148	
3/8" Tube weld	7	Φ50.3	50.8	18.2	M5x0.8	Φ38.1	38	69.8	148	
1/2" Tube weld	7	Φ50.3	50.8	18.2	M5x0.8	Φ38.1	38	90.8	148	
3/4" Tube weld	7	Φ50.3	50.8	18.2	M5x0.8	Φ38.1	38	165.2	148	

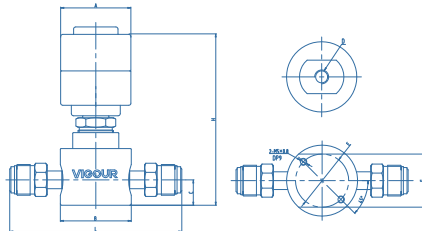

pneumatic actuator (normally closed 206 bar)

End Connections	Orifice (mm)	Dimensions (mm)								
		A	B	C	D	E	F	L	H	
1/4" VFS male	4.4	Φ50.3	50.8	18.2	M5x0.8	Φ38.1	38	101.6	125	
1/4" VFS female	4.4	Φ50.3	50.8	18.2	M5x0.8	Φ38.1	38	101.6	125	
1/2" VFS male	7	Φ50.3	50.8	18.2	M5x0.8	Φ38.1	38	123.2	125	
1/2" VFS female	7	Φ50.3	50.8	18.2	M5x0.8	Φ38.1	38	123.2	125	
3/4" VFS male	7	Φ50.3	50.8	18.2	M5x0.8	Φ38.1	38	177.8	125	
3/4" VFS female	7	Φ50.3	50.8	18.2	M5x0.8	Φ38.1	38	177.8	125	
3/8" Tube weld	7	Φ50.3	50.8	18.2	M5x0.8	Φ38.1	38	69.8	125	
1/2" Tube weld	7	Φ50.3	50.8	18.2	M5x0.8	Φ38.1	38	90.8	125	
3/4" Tube weld	7	Φ50.3	50.8	18.2	M5x0.8	Φ38.1	38	165.2	125	

Ordering Information

VDV38UBS - M - MV8 - MV8 - VS - H - L - P

Materials

S: 316L

Actuator

M: manual actuator

PC: pneumatic actuator (normally closed)

End Connection

MV4: 1/4" VFS male

FV4: 1/4" VFS female

MV8: 1/2" VFS male

FV8: 1/2" VFS female

TW6: 3/8" tube weld

TW8: 1/2" tube weld

MV12: 3/4" VFS male

FV12: 3/4" VFS female

TW12: 3/4" tube weld

* Other connection standard, consult factory

Valve Seat Option

None: PCTFE (standard)

VS: Vespel®

Work Pressure

H: 3000 psig *

M: 1300 psig

*The pressure for the 3/4" connection is 1650 psig

Process Specification

None: VS001B

P: VS001A

* For details, please refer to the appendix

Optional

None: Circular handle

W: Round handwheel with sight window

LO: Round Knob Pull, then turn to open lock out / tag out

L: Right-angle handle

*Option W: 1300 psig max only

*Option LO: 1300 psig max only

*Option L: 3000 psig max only

Diaphragm Valve VDV38UC Series

Product Feature

- Suitable for ultra-pure, flammable or toxic fluid lines in semiconductor manufacturing equipment and facilities
- Direct diaphragm construction with superior sealing performance, remarkable durability, compactness and particle free performance
- Valve open and closed position is easily visible at a glance
- Excellent gas displacement characteristics
- EP treatment is standard for all wetted surfaces
- Standard seat material is PCTFE, Polyimide is option



1/2" pneumatic actuator



1/2" manual actuator



1/2" Right-angle handle



3/4" manual actuator (Lockable)

Temperature / Pressure Rating

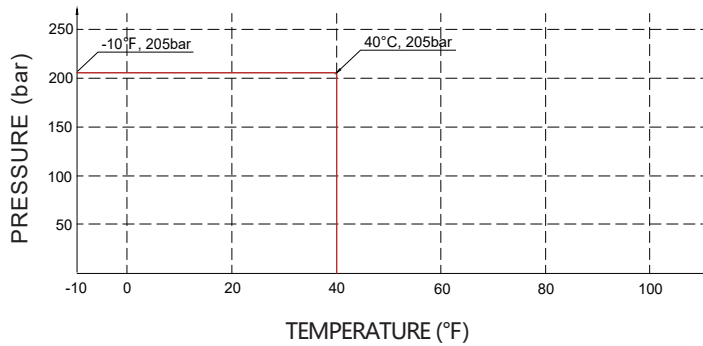

Technical Data

Max. Working Pressure:	3000 psig (200bar) / 1300 psig (90bar)
Actuation Pressure:	70~110 psig (5~8bar)
Max. Working Temp.:	-40°F ~ 150°F (-40°C ~ 65°C)
Surface finish:	7µin. Ra
Materials	
Body:	see ordering info
Diaphragm:	Elgiloy®
Seat packing:	PCTFE
Handle:	AL
Internal Leakage Allowance:	1x10 ⁻⁹ mbar·l/s He
External Leakage Allowance:	1x10 ⁻⁹ mbar·l/s He
Flow capacity:	manual actuator Cv=1.0 pneumatic actuator Cv=1.0 (90bar) / Cv=0.7 (206 bar)
Weight:	approx. 1.36kg (depending on connections or options)

Diaphragm Valve VDV38UC Series

Dimensions (mm)

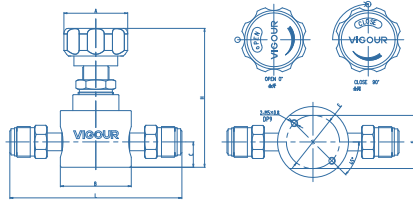

manual actuator (90 bar)

End Conections	Orifice (mm)	Dimensions (mm)						
		A	B	C	E	F	L	H
1/4" VFS male	4.4	Φ47.8	50.8	18.2	Φ38.1	38	101.6	100
1/4" VFS female	4.4	Φ47.8	50.8	18.2	Φ38.1	38	101.6	100
1/2" VFS male	7	Φ47.8	50.8	18.2	Φ38.1	38	123.2	100
1/2" VFS female	7	Φ47.8	50.8	18.2	Φ38.1	38	123.2	100
3/4" VFS male	7	Φ47.8	50.8	18.2	Φ38.1	38	177.8	100
3/4" VFS female	7	Φ47.8	50.8	18.2	Φ38.1	38	177.8	100
3/8" Tube weld	7	Φ47.8	50.8	18.2	Φ38.1	38	69.8	100
1/2" Tube weld	7	Φ47.8	50.8	18.2	Φ38.1	38	90.8	100
3/4" Tube weld	7	Φ47.8	50.8	18.2	Φ38.1	38	165.2	100

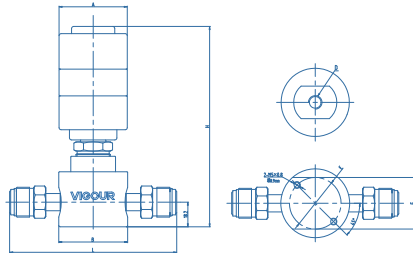

pneumatic actuator (normally closed 90 bar)

End Conections	Orifice (mm)	Dimensions (mm)							
		A	B	C	D	E	F	L	H
1/4" VFS male	4.4	Φ50.3	50.8	18.2	M5x0.8	Φ38.1	38	101.6	148
1/4" VFS female	4.4	Φ50.3	50.8	18.2	M5x0.8	Φ38.1	38	101.6	148
1/2" VFS male	7	Φ50.3	50.8	18.2	M5x0.8	Φ38.1	38	123.2	148
1/2" VFS female	7	Φ50.3	50.8	18.2	M5x0.8	Φ38.1	38	123.2	148
3/4" VFS male	7	Φ50.3	50.8	18.2	M5x0.8	Φ38.1	38	177.8	148
3/4" VFS female	7	Φ50.3	50.8	18.2	M5x0.8	Φ38.1	38	177.8	148
3/8" Tube weld	7	Φ50.3	50.8	18.2	M5x0.8	Φ38.1	38	69.8	148
1/2" Tube weld	7	Φ50.3	50.8	18.2	M5x0.8	Φ38.1	38	90.8	148
3/4" Tube weld	7	Φ50.3	50.8	18.2	M5x0.8	Φ38.1	38	165.2	148

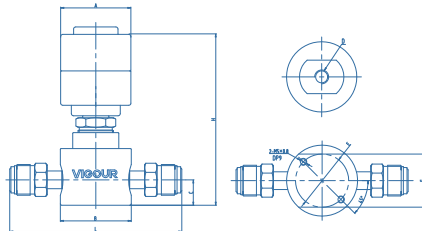

pneumatic actuator (normally closed 206 bar)

End Conections	Orifice (mm)	Dimensions (mm)							
		A	B	C	D	E	F	L	H
1/4" VFS male	4.4	Φ50.3	50.8	18.2	M5x0.8	Φ38.1	38	101.6	125
1/4" VFS female	4.4	Φ50.3	50.8	18.2	M5x0.8	Φ38.1	38	101.6	125
1/2" VFS male	7	Φ50.3	50.8	18.2	M5x0.8	Φ38.1	38	123.2	125
1/2" VFS female	7	Φ50.3	50.8	18.2	M5x0.8	Φ38.1	38	123.2	125
3/4" VFS male	7	Φ50.3	50.8	18.2	M5x0.8	Φ38.1	38	177.8	125
3/4" VFS female	7	Φ50.3	50.8	18.2	M5x0.8	Φ38.1	38	177.8	125
3/8" Tube weld	7	Φ50.3	50.8	18.2	M5x0.8	Φ38.1	38	69.8	125
1/2" Tube weld	7	Φ50.3	50.8	18.2	M5x0.8	Φ38.1	38	90.8	125
3/4" Tube weld	7	Φ50.3	50.8	18.2	M5x0.8	Φ38.1	38	165.2	125

Ordering Information

VDV38UCSLV - M - MV8 - MV8 - VS - H - L - P

Materials

SLV: 316L secondary remelt

Actuator

M: manual actuator

PC: pneumatic actuator (normally closed)

End Connection

MV4: 1/4" VFS male

FV4: 1/4" VFS female

MV8: 1/2" VFS male

FV8: 1/2" VFS female

TW6: 3/8" tube weld

TW8: 1/2" tube weld

MV12: 3/4" VFS male

FV12: 3/4" VFS female

TW12: 3/4" tube weld

* Other connection standard, consult factory

Valve Seat Option

None: PCTFE (standard)

VS: Vespe®

Work Pressure

H: 3000 psig *

M: 1300 psig

*The pressure for the 3/4" connection is 1650 psig

Process Specification

P: VS001A

* For details, please refer to the appendix

Optional

None: Circular handle

W: Round handwheel with sight window

LO: Round Knob Pull, then turn to open lock out / tag out

L: Right-angle handle

*Option W: 1300 psig max only

*Option LO: 1300 psig max only

*Option L: 3000 psig max only

Diaphragm Valve VDV39UB Series

Product Feature

- Suitable for ultra-pure, flammable or toxic fluid lines in semiconductor manufacturing equipment and facilities
- Direct diaphragm construction with superior sealing performance, remarkable durability, compactness and particle and dead-space-free performance
- Valve open and closed position is easily visible at a glance
- Excellent gas displacement characteristics
- EP treatment is standard for all wetted surfaces
- Standard seat material is PCTFE, Polyimide / PFA is option



3/4" manual actuator

Temperature / Pressure Rating

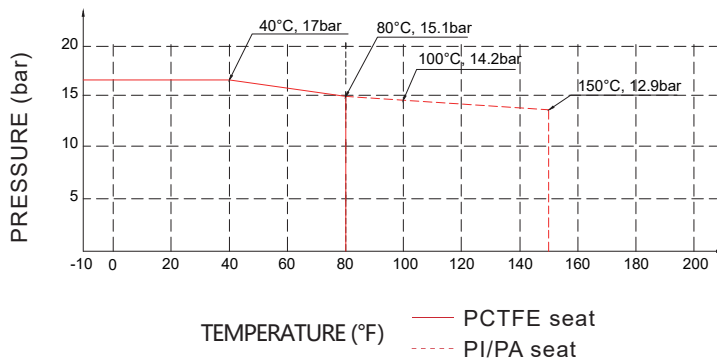

1/2" manual actuator

Technical Data

Max. Working Pressure:	300 psig (20bar)
Max. Working Temp.:	14°F ~ 104°F (-10°C ~ 40°C)
Surface finish:	10µin. Ra
Materials	
Body:	see ordering info
Diaphragm:	Elgiloy® (316L optional)
Seat packing:	PCTFE (PFA / VESPEL optional)
Handle:	AL
Internal Leakage Allowance:	1x10 ⁻⁹ mbar·l/s He
External Leakage Allowance:	1x10 ⁻⁹ mbar·l/s He
Flow capacity:	Cv=2.8
Weight:	approx. 1.45kg (depending on connections or options)

Diaphragm Valve VDV39UB Series

Dimensions (mm)

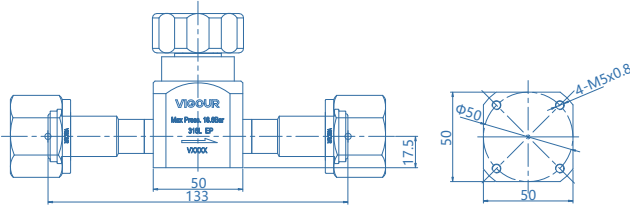

3/4 manual actuator (VFS female)

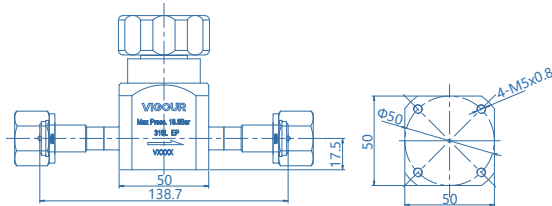

1/2 manual actuator (VFS female)

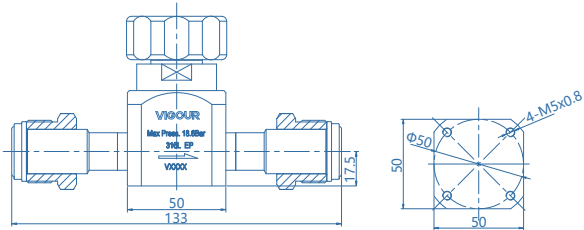

3/4 manual actuator (VFS male)

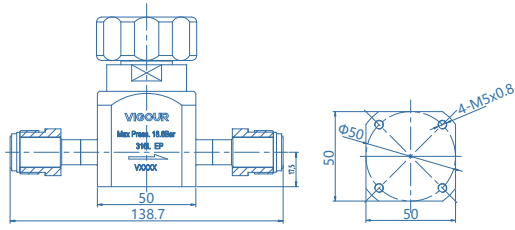

1/2 manual actuator (VFS male)

Ordering Information

VDV39UBS - M - MV8 - MV8 - PA - P

Materials

S: 316L

Actuator

M: manual actuator

End Connection

- FV12: 3/4" VFS (F)
- MV12: 3/4" VFS (M)
- TW12: 3/4" tube weld
- FV8: 1/2" VFS (F)
- MV8: 1/2" VFS (M)
- TW8: 1/2" tube weld

Process Specification

None: VS001B

P: VS001A

* For details, please refer to the appendix..

Valve Seat Option

None: PCTFE (standard)

VS: Vespel®

PA: PFA

* Other connection standard, consult factory

Bellows Valve

VUBV Series

Product Feature

- 316L stainless steel construction
- Tube fitting, tube welding, and VFS fitting joints
- Easy to clean to keep operation clean
- Excellent gas displacement characteristics
- The product is fabricated in compliance with the VS001B process specification
- EP treatment is standard for all wetted surfaces
- Standard seat material is PCTFE, Vespe^l® is option
- All-metal seal to atmosphere



Flowchart

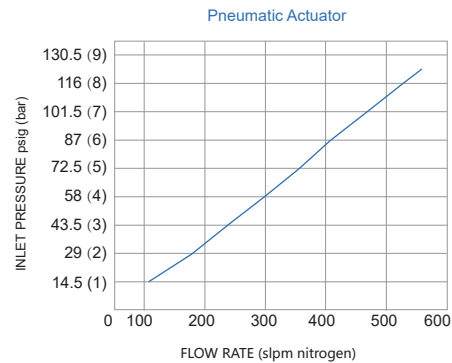
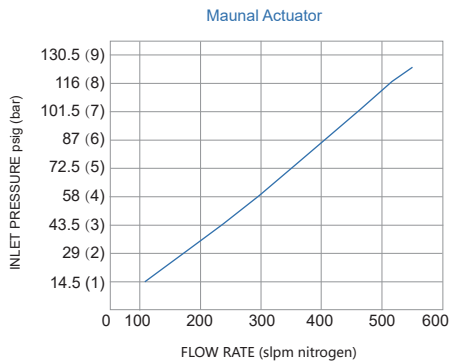

Technical Data

Manual Pressure:	Vacuum 500 psig (35bar)
Pneumatic Pressure:	Vacuum 125 psig (8.6bar)
Operating Pressure:	45~120 psig (3.2~8.2bar)
Surface finish:	10µin. Ra Standard (7µin. Ra / 5µin. Ra optional)
Working Temp.:	-40°F ~ 200°F (-40°C ~ 93°C)
Materials	
Body:	316L
Bellows:	A269 / A240 stainless steel
Seat packing:	PCTFE
Handle:	AL
Internal Leakage Allowance:	<1x10 ⁻⁹ mbar·l/s He
External Leakage Allowance:	<1x10 ⁻⁹ mbar·l/s He
Flow capacity:	Cv=0.3
Weight:	approx. 1.54kg (depending on connections or options)

Dimensions (mm)

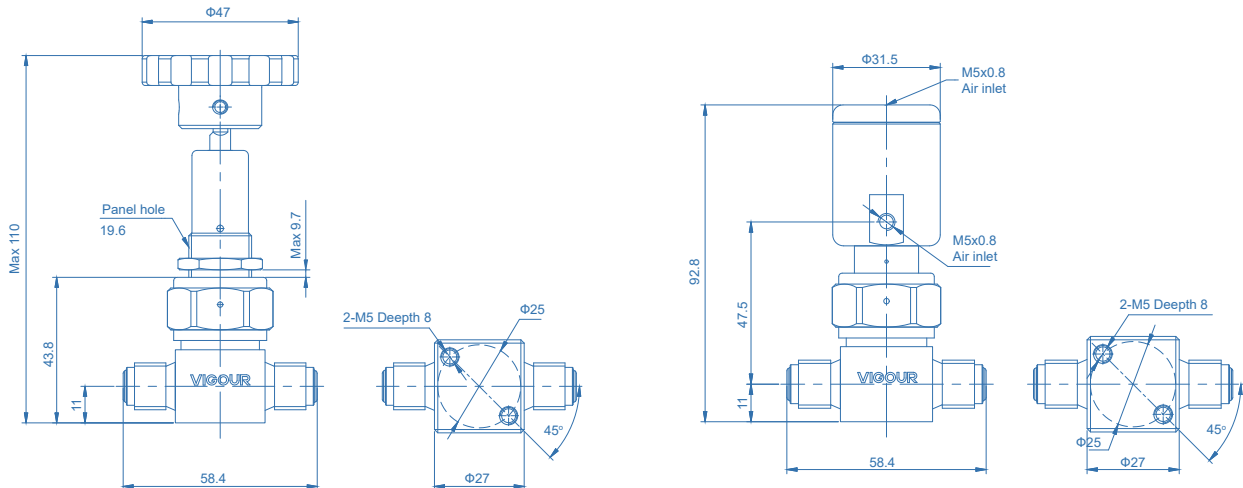

Ordering Information

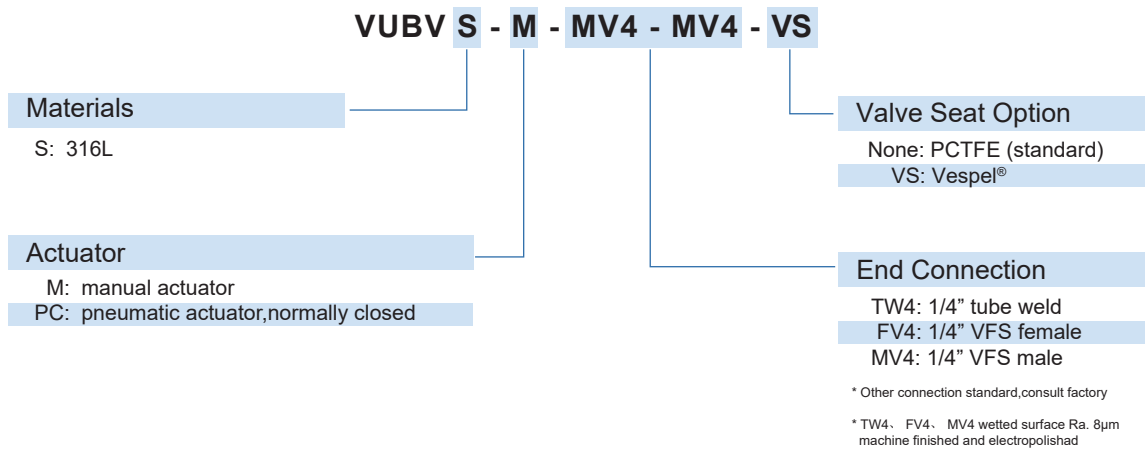

Bellows Valve VUBV2 Series

Product Feature

- 316L stainless steel construction
- Tube welding and VFS fitting connection
- Easy to clean
- Excellent airtightness characteristics
- The product is fabricated in compliance with the VS001B process specification
- EP treatment is standard for all wetted surfaces
- The standard seat material is PCTFE, Vespel® (optional)
- All-metal seal to atmosphere



Manual Actuator 3/4~1"



Manual Actuator 1.5~2"



Pneumatic actuator 1.5~2"

parameter specification

Connections	Size	Cv	Max Pressure
MV12	3/4"	14.5	Manual: 375psig (25.8bar) Pneumatic: 250psig (17.2bar)
FV12			
TW12			
MV16	1"	21	
FV16			
TW16			
TW24	1.5"	46	
TW32	2"	52	

Technical Data

Manual Pressure:	Vacuum to 375 psig (25.8bar)
Pneumatic Pressure:	Vacuum to 250 psig (17.2 bar)
Driving force:	4.1~6.9 bar (3/4" or 1"), 6.2~6.9 bar (1.5" or 2")
Surface finish:	10µin. Ra
Working Temp:	-22°F ~ 180°F (-30°C ~ 82°C)
Materials	
Body:	316L
Bellows:	SUS316L / Hastelloy®
Seat packing:	PCTFE
Handle:	AL
Internal Leakage Allowance:	<1x10 ⁻⁹ mbar·l/s He
External Leakage Allowance:	<1x10 ⁻⁹ mbar·l/s He
Flow capacity:	See parameter specification

Dimensions (mm)

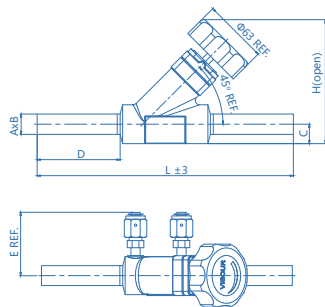

Manual Actuator 3/4~1"

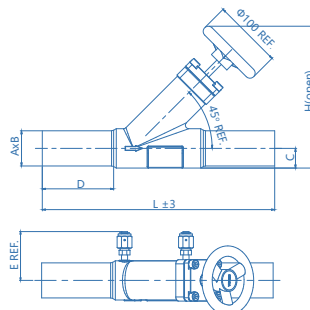

Manual Actuator 1.5~2"

Manual Actuator

Size	Dimensions (mm)						
	A	B	C	D	E	L	H
3/4"	Φ19.05	1.65	18.03	77.2	57	239	105.2
1"	Φ25.4	1.65	18.03	77.2	57	239	105.2
1.5"	Φ38.1	1.65	28.7	77.7	67	284.7	211.1
2"	Φ50.8	1.65	28.7	103	67	335.5	211.1

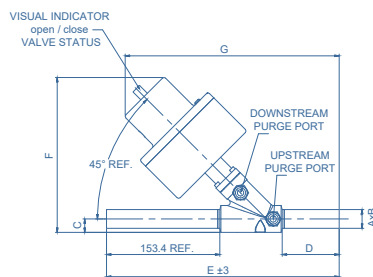

Pneumatic actuator 1"

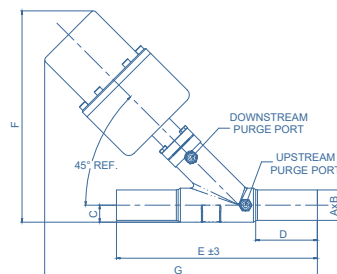

Pneumatic actuator 2"

Pneumatic actuator (normally closed)

Size	Dimensions (mm)						
	A	B	C	D	E	F	G
3/4"	Φ19.05	1.65	18.2	77.2	315.2	209	290.0
1"	Φ25.4	1.65	18.2	77.2	315.2	209	290.0
1.5"	Φ38.1	1.65	28.4	77.7	284.7	352.8	455.0
2"	Φ50.8	1.65	28.4	103.0	335.5	352.8	455.0

Ordering Information

VUBV2 S - M - MV12 - MV12 - P1 - P2 - VS

Materials

S: 316L

Actuator

M: manual actuator

PC: pneumatic actuator, normally closed

End Connection

FV12: 3/4" VFS female

MV12: 3/4" VFS male

TW12: 3/4" tube weld

FV16: 1" VFS female

MV16: 1" VFS male

TW16: 1" tube weld

TW24: 1.5" tube weld

TW32: 2" tube weld

Valve Seat Option

None: PCTFE (standard)

VS: Vespel®

Outlet Purge Connection

None: No outlet purge

P2: 1/4" outlet purge

P2V: 1/4" outlet purge valve

Inlet Purge Connection

None: No inlet purge

P1: 1/4" inlet purge

P1V: 1/4" inlet purge valve

* Other connection standard, consult factory

Metering Bellows Valve VBMV Series

Product Feature

- Micrometer-style handle for precise and repeatable flow setting.
- Micrometer handle measures stem position in 0.001 in. (0.025 mm) increments.
- The product is fabricated in compliance with the VS001B process specification
- Working pressure up to 700 psig (48.2 bar)
- Temperature up to 315°C (600°F)
- 316 stainless steel construction
- Cv = 0.019 with metering stem tip
- Cv = 0.30 with regulating stem tip



Technical Data

Valve body vs. bellows seal	Stem tip	Stem taper	Cv	Internal volume in.3 (cm3)	Series
Gasket	Metering	3°	0.019	0.07 (1.1)	VBMV
	Regulation	20°	0.3	0.11 (1.6)	VBMRV

Flow Coefficient at Turns Open

Flow Data at 20°C (70°F)

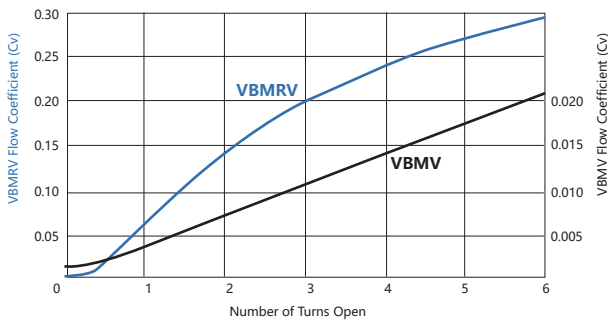

Pressure-temperature rating

Material	316 SS
Series	VBMV / VBMRV
Temperature, °C(°F)	operating pressure, psig (bar)
-28 (-20) to 37 (100)	700 (48.2)
93 (200)	610 (42.0)
148 (300)	530 (36.5)
204 (400)	450 (31.0)
260 (500)	375 (25.8)
315 (600)	300 (20.6)

Metering Bellows Valve VBMV Series

Dimensions (mm)

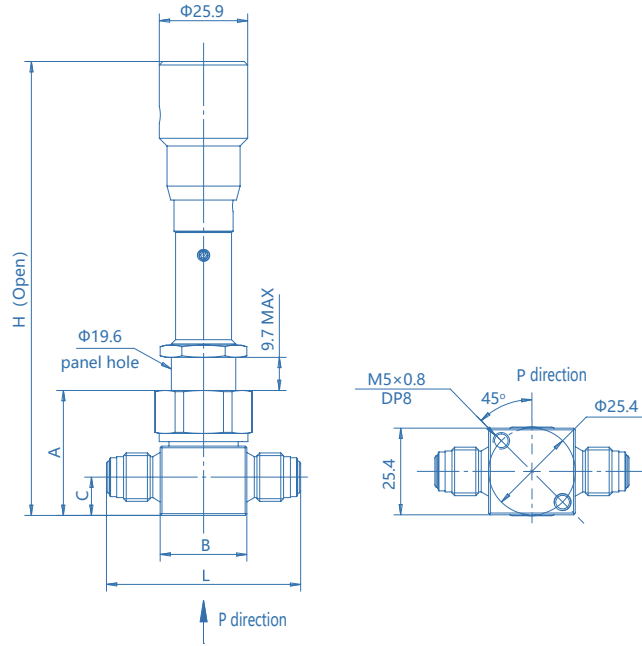

Ordering Information

End Connections		Series	Ordering Number	Dimensions, (mm)					
Fitting	Inlet / Outlet			Tube OD	H	A	C	B	L
Tube Fitting	1/4"	VBMV	SS-VBMV-04-04	1.4	133	36.8	14.2	26.9	62.5
		VBMRV	SS-VBMRV-04-04	4.2	133				
	6mm	VBMV	SS-VBMV-6M-6M	1.4	133	36.8			
		VBMRV	SS-VBMRV-6M-6M	4.2	133				
Tube Weld	3/8"	VBMV	SS-VBMV-TW6-TW6	1.4	133	36.8	14.2	25.4	42.7
		VBMRV	SS-VBMRV-TW6-TW6	4.2					
VFS male	1/4"	VBMV	SS-VBMV-MV4-MV4	1.4	133	36.8	11.2	25.4	56.9
		VBMRV	SS-VBMRV-MV4-MV4	4.2	133				

Metering Valve VMV Series

Product Features

- Low pressure metering valves
- Body materials: 316
- Panel installation is possible
- The product is fabricated in compliance with the VS001B process specification
- Vernier handles options
- Straight and Angle flow patterns
- Working pressure: Max. 2000psig (138bar)
- Straight-pattern flow coefficients (Cv) from 0.004 to 0.16



Technical Data

Series	Pressure-Temperature Ratings		Orifice in. (mm)	Shutoff Service	Stem Taper (Included Angle)
	Temperature °C	Working Pressure bar			
A type	-23°C to +204°C (FKM O-rings)	137	0.032 (0.81)	No	1°
B type			0.056 (1.42)	No	3°
C type	-23°C to +148°C (Buna N, O-rings)	68.9 ^①	0.128 (3.25)	Yes ^②	6°

① Downstream pressure 500 psig (34.4 bar) max when valve requires adjustment at pressure due to strength limitations of the fine-pitch threads and high operating torque.

② Stainless steel L series valves are not recommended for shutoff in vacuum or gas service, or for repetitive shutoff in liquid service.

Flow Coefficient at Turns Open

Flow Data at 70°F (20°C)

A type Metering Valves

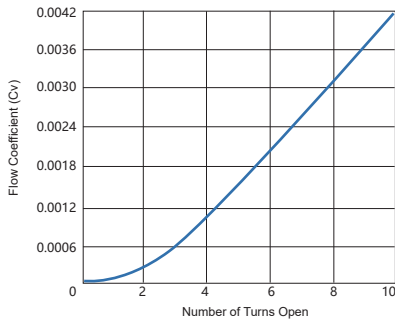

B type Metering Valves

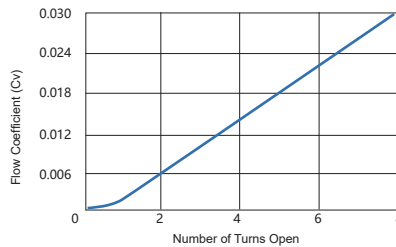

C type Metering Valves

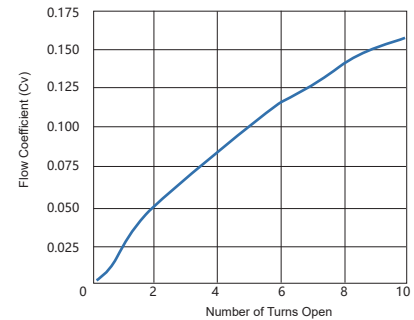

Max. Flow Cv=0.004	
Pressure Drop to Atmosphere bar	Air Flow std L/min
0.68	1.1
3.4	2.8
6.8	5.6

Max. Flow Cv=0.03	
Pressure Drop to Atmosphere bar	Air Flow std L/min
0.68	9.3
3.4	25.4
6.8	42.4

Max. Flow Cv=0.16	
Pressure Drop to Atmosphere bar	Air Flow std L/min
0.68	56.6
3.4	181
6.8	323

Dimensions

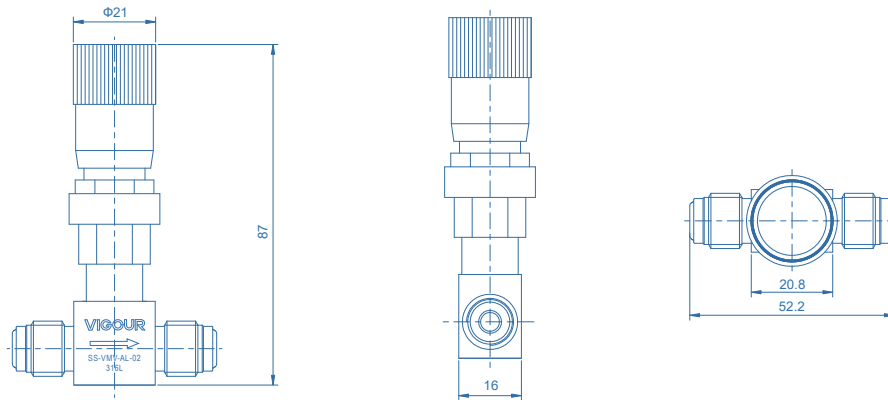

End Connections		Ordering Number	Dimensions, in. (mm)					
Inlet/Outlet	Size		L	H	H1	H2	E	G
A type (Straight Pattern)								
Tube Fittings	1/16 in.	SS-VMV-A-01	1.56 (39.6)	2.34 (59.4)	0.92 (23.4)	/	0.38 (9.6)	0.45 (11.4)
	1/8 in.	SS-VMV-A-02	1.90 (48.3)					
	1/4 in.	SS-VMV-A-04	2.04 (51.8)					
	3mm	SS-VMV-A-3M	1.90 (48.3)					
	6mm	SS-VMV-A-6M	2.04 (51.8)					
VFS Male	1/4 in.	SS-VMV-A-MV4	2.06 (52.3)					
A type (Angle Pattern)								
Tube Fittings	1/16 in.	SS-VMV-AL-01	0.81 (20.6)	3.22 (81.8)	0.92 (23.4)	0.88 (22.4)	0.38 (9.6)	0.45 (11.4)
	1/8 in.	SS-VMV-AL-02	0.98 (24.9)	3.22 (81.8)		0.98 (24.9)		
	1/4 in.	SS-VMV-AL-04	1.02 (25.9)	3.36 (85.3)		1.02 (25.9)		
	3mm	SS-VMV-AL-3M	0.98 (24.9)	3.32 (84.3)		0.99 (25.1)		
Male NPT / Tube Fittings	1/8 in.	SS-VMV-AL-M2-02	0.98 (24.9)	3.07 (78.0)		0.98 (24.9)		
B type (Straight Pattern)								
Tube Fittings	1/8 in.	SS-VMV-B-02	2.02 (51.3)	2.78 (70.6)	1.56 (39.6)	/	0.50 (12.7)	0.58 (14.7)
	1/4 in.	SS-VMV-B-04	2.20 (55.9)					
	3mm	SS-VMV-B-3M	2.02 (51.3)					
	6mm	SS-VMV-B-6M	2.20 (55.9)					
Male NPT	1/8 in.	SS-VMV-B-M2	1.50 (38.1)					
	1/4 in.	SS-VMV-B-M4	1.96 (49.8)					
Female NPT	1/8 in.	SS-VMV-B-F2	1.94 (49.3)					
VFS Male	1/4 in.	SS-VMV-B-MV4	2.06 (52.3)					
B type (Angle Pattern)								
Tube Fittings	1/8 in.	SS-VMV-BL-02	1.01 (25.7)	3.30 (83.8)	1.07 (27.2)	1.01 (25.7)	0.50 (12.7)	0.58 (14.7)
	1/4 in.	SS-VMV-BL-04	1.10 (27.9)	3.39 (86.1)		1.10 (27.9)		
	3mm	SS-VMV-BL-3M	1.01 (25.7)	3.30 (83.8)		1.01 (25.7)		
	6mm	SS-VMV-BL-6M	1.10 (27.9)	3.39 (86.1)		1.10 (27.9)		
Male NPT	1/8 in.	SS-VMV-BL-M2	0.75 (19.1)	3.04 (77.2)		0.75 (19.1)		
	1/4 in.	SS-VMV-BL-M4	0.98 (24.9)	3.27 (83.1)		1.02 (25.9)		
Male NPT / Tube Fittings	1/8 in.	SS-VMV-BL-M2-02	1.01 (25.7)	3.04 (77.2)		0.75 (19.1)		
Female NPT	1/8 in.	SS-VMV-BL-F2	0.97 (24.6)	3.26 (82.8)		0.97 (24.6)		

Metering Valve

VMV Series

Dimensions

End Connections		Ordering Number	Dimensions, in. (mm)					
Inlet/Outlet	Size		L	H	H1	H2	E	G
C type (Straight Pattern)								
Tube Fittings	1/4 in.	SS-VMV-C-04	2.34 (59.4)	2.82 (71.6)	1.26 (32.0)	/	1.13 (28.7)	0.58 (14.7)
	3/8 in.	SS-VMV-C-06	2.46 (62.5)					
	6mm	SS-VMV-C-6M	2.34 (59.4)					
Male NPT	1/4 in.	SS-VMV-C-M4	2.00 (50.8)					
C type (Angle Pattern)								
Tube Fittings	1/4 in.	SS-VMV-CL-04	1.17 (29.7)	3.77 (95.8)	1.04 (26.4)	1.17 (29.7)	1.13 (28.7)	0.58 (14.7)
	6mm	SS-VMV-CL-6M						

Options and Accessories



Vernier Handle

Product Features:

- Helps ensure repeatable flow adjustments.
- Provides readings accurate to 1/25 turn.
- Kits contain all parts necessary to add a Vernier handle to an existing valve.

Ordering Example:

SS-VMV-AL-02-Y

Ordering Information

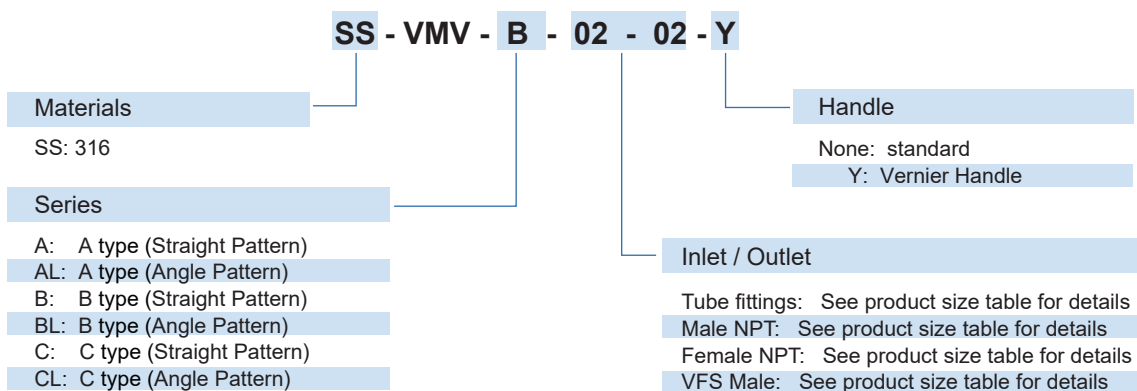

Atomic Layer Deposition Valve VALD Series

Product Feature

- Ultrahigh cycle life with high-speed actuation
- Normally closed pneumatic actuation
- Switch position sensor optional
- The product is fabricated in compliance with the VS001A process specification
- Suitable for ultrahigh-purity applications
- Modular surface-mount, tube butt weld, and VFS end connections
- Opening and closing time of less than 5ms
- Fully swept flow path facilities
- Thermal isolation coupling optional

Technical Data

Max. Working Pressure:	145 psig (10bar)
Actuation Pressure:	50~90 psig (3.5~6.2 bar)
Working Temp.:	-9°F ~ 399°F (-23°C ~ 200°C) Body Max. Temp 200°C
Materials	
Body:	see ordering info
Diaphragm:	Elgiloy®
Seat:	High purity PFA
Flow capacity:	VALD3 Cv=0.27, VALD6 Cv=0.62
Weight:	approx. 1.54kg



VALD3



VALD3T



VALD6

Dimensions (mm)

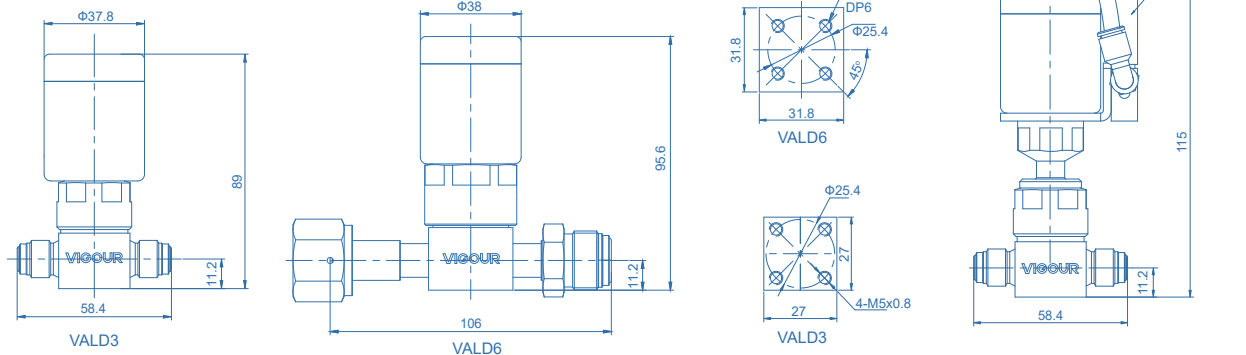

Ordering Information

VALD3 S - PC - MV4 - MV4 - S - V

Type	3: Max. Working Temp. 120°C 1/4"	3T: Max. Working Temp. 200°C 1/4"	6: Max. Working Temp. 120°C 1/2"	6T: Max. Working Temp. 200°C 1/2"	Optional	None: Without solenoid pilot valve V: Solenoid pilot valve
Materials	S: 316L SLV: 316L secondary remelt	End Connection	TW4: 1/4" tube weld FV4: 1/4" VFS (F) MV4: 1/4" VFS (M)	Optional	None: Without electronic actuator-position sensor S: Electronic actuator-position sensor	
Actuator	PC: pneumatic actuator, normally closed	Optional	TW8: 1/2" tube weld FV8: 1/2" VFS (F) MV8: 1/2" VFS (M)			

* Other connection standard, consult factory

Vacuum Generator

VVG Series

Product Feature

- Max. vacuum pressure: -90kPa
- Stainless steel 316L construction
- MMHG (Torr) vacuum generators
- The product is fabricated in compliance with the VS001B process specification
- With a minimum source nitrogen pressure of 90 psig (6bar)
- 100% helium leak test



Dimensions (mm)

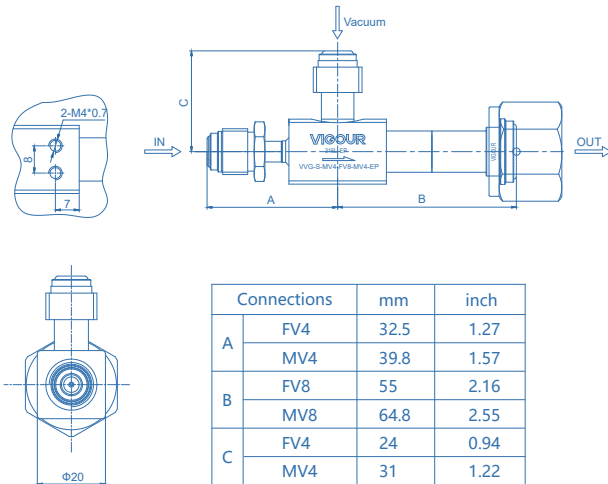

Vacuum and Flow Specification

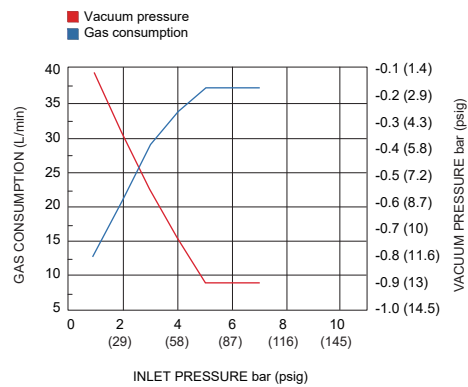

Technical Data

Type:	Vacuum Generators
Max. Vacuum pressure:	-90kPa
Inlet pressure at limiting vacuum pressure:	70psig (5 bar)
Flow at limiting vacuum pressure:	37L/min
Body Material:	SS 316L
Max. Working pressure:	150psig (10 bar)
Temperature range:	0~150°C
Source Gas:	Nitrogen

Ordering Information

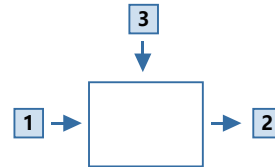

Inlet/Outlet Connecion

FV4: 1/4" VFS female
FV8: 1/2" VFS female

MV4: 1/4" VFS male
MV8: 1/2" VFS male

* Other connection standard, consult factory.

Port Selection

VVG - S - 1 - 2 - 3 - EP

Materials

S: 316L

Inlet Connection

MV4: 1/4" VFS male

Outlet Connection

FV8: 1/2" VFS female

MV8: 1/2" VFS male

Surface Finish

BA: 0.4 µin. Ra

EP: 0.25 µin. Ra

Vacuum Connection

FV4: 1/4" VFS female

MV4: 1/4" VFS male

Ordering Example

VVG - S - MV4 - FV8 - MV4
| | |
1 - 2 - 3



Vacuum Generator

VVGV1 Series

Product Feature

- Pneumatic actuator, normally closed
- Monoblock vacuum venturi, diaphragm valve and check valve
- Compact design
- Maximum vacuum: -88 KPa
- The product is fabricated in compliance with the VS001B process specification



Dimensions (mm)

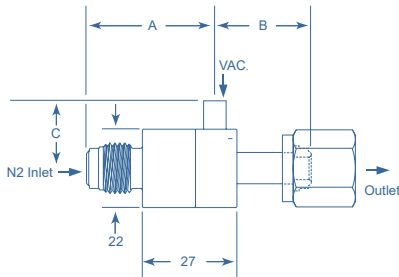

Connections	Dimensions (mm)		
	A	B	C
MV4, FV4	36.3	-	35
FV4	-	-	35
TW4	-	-	19
FV8-MV8	-	41.6	-
TW6	-	24.4	-

Vacuum and Flow Specification

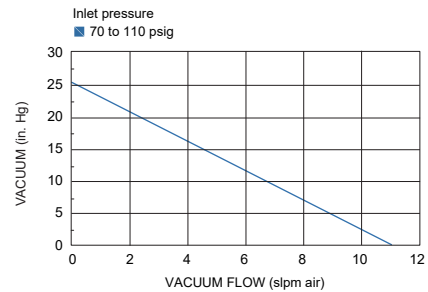
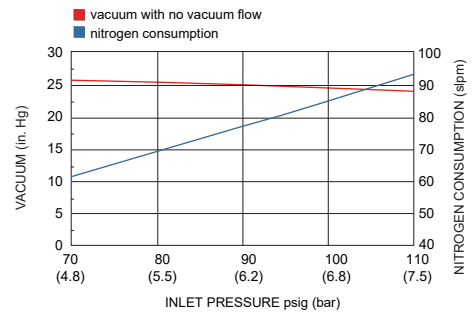

Technical Data

N2 Inlet pressure:	70 to 110 psig (4.8 to 7.6 bar)
Vacuum port maximum pressure:	3,500 psig (241 bar)
Check valve cracking pressure:	3 psid (0.2 bar) (differential)
Operating temperature:	-14~160°F (-10~71°C)
Inlet connection:	1/4" VFS fitting
Outlet connection:	1/2" VFS fitting, 3/8" Tube weld
Vacuum port connection:	1/4" VFS fitting / Tube weld
Actuation connection:	M5
Actuation pressure:	60 to 110 psig (4 to 7.6 bar)
Leakage:	Bubble tight
Materials	
Body:	316L
O-ring:	FKM / FFKM (option)

Ordering Information



Inlet/Outlet Connecion

FV4: 1/4" VFS female
FV8: 1/2" VFS female

MV4: 1/4" VFS male
MV8: 1/2" VFS male

TW4: 1/4" Tube weld
TW6: 3/8" Tube weld

* Other connection standard, consult factory.

Port Selection

VVG1S - 1 - 2 - 3 - 05 - K

Material

S: 316L

Inlet Connection

MV4: 1/4" VFS male

Outlet Connection

MV8: 1/2" VFS male
FV8: 1/2" VFS female
TW6: 3/8" tube weld

O-ring

none: FKM
K: FFKM

Flow

None: No continuous exhaust flow
03: 1~2.5 slpm constant bleed
05: 2~5 slpm constant bleed
08: 5~8 slpm constant bleed
15: 10~15 slpm constant bleed

*at 80 psig N2

Vacuum Connection

MV4: 1/4" VFS male
FV4: 1/4" VFS female
TW4: 1/4" tube weld

Ordering Example

VVVG1S - MV4 - FV8 - FV4 - 05 - K

1 - 2 - 3

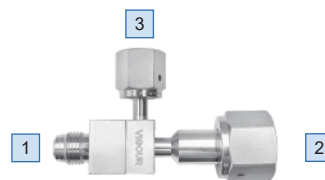

Vacuum Generator

VVGV2 Series

Product Feature

- Manual or pneumatic actuation
- Monoblock vacuum venturi, diaphragm valve and check valve
- Compact design
- Maximum vacuum: -88 KPa
- The product is fabricated in compliance with the VS001B process specification



Dimensions (mm)

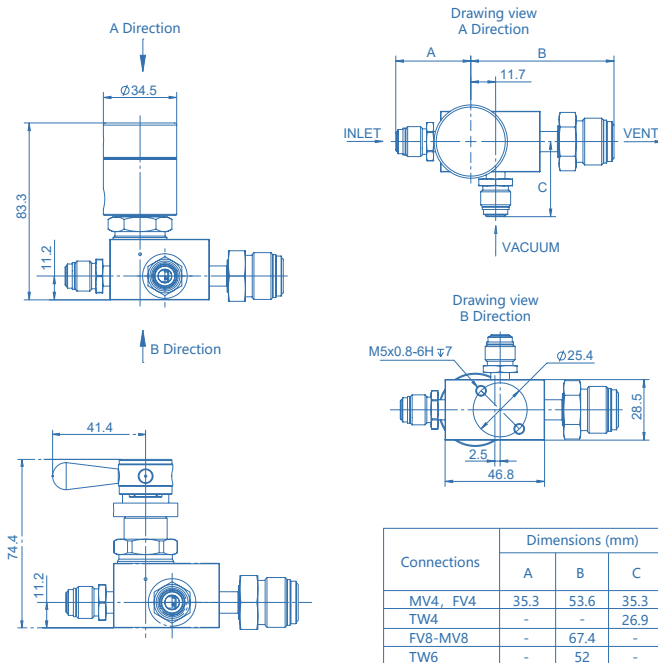

Vacuum and Flow Specification

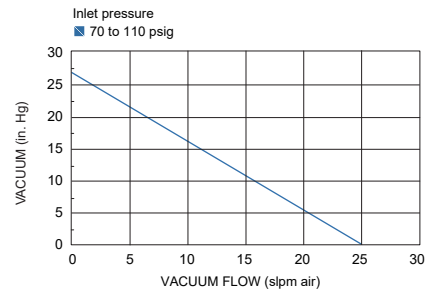
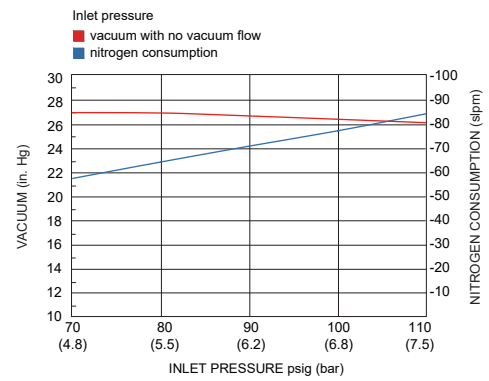

Technical Data

N2 Inlet pressure:	70 to 110 psig (4.8 to 7.6 bar)
N2 Flow:	60 slpm
Vacuum port maximum pressure:	3,000 psig (207 bar)
Check valve cracking pressure:	3 psid (0.2 bar) (differential)
Operating temperature:	-14~160°F (-10~71°C)
Inlet connection:	1/4" VFS fitting
Outlet connection:	1/4" 1/2" VFS fitting, 3/8" Tube weld
Vacuum port connection:	1/4" VFS fitting / Tube weld
Actuation connection:	M5
Actuation pressure:	70 to 110 psig (4.8 to 7.6 bar)
Leakage:	4x10 ⁻⁸ mbar-l/s He (Inboard) 2x10 ⁻¹⁰ mbar-l/s He (Outboard)
Materials	
Body:	316L
O-ring:	FKM / FFKM (option)

Ordering Information

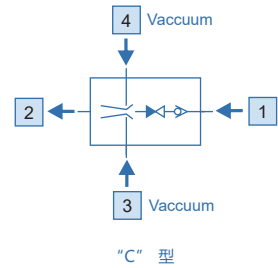
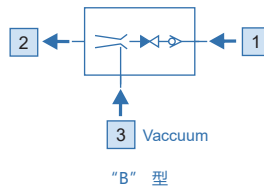
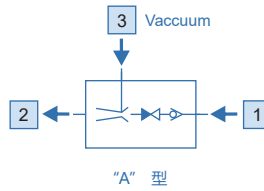
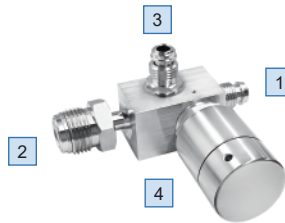

Inlet/Outlet Connection

FV4: 1/4" VFS female
FV8: 1/2" VFS female

MV4: 1/4" VFS male
MV8: 1/2" VFS male

TW4: 1/4" Tube weld
TW6: 3/8" Tube weld

* Other connection standard, consult factory.

Port Selection

VVG2S - PC - C - 1 - 2 - 3 - 4 - 05 - K

Material

S: 316L

Type

M: Manual actuation
PC: Pneumatic actuation
(normally closed)

Porting

A: 3P A type
B: 3P B type
C: 4P

Inlet Connection

MV4: 1/4" VFS male
FV4: 1/4" VFS female

Outlet Connection

MV4: 1/4" VFS male
FV4: 1/4" VFS female
MV8: 1/2" VFS male
FV8: 1/2" VFS female
TW6: 3/8" tube weld

O-ring

none: FKM
K: FFKM

Flow

None: No continuous exhaust flow
05: 2~5 slpm constant bleed
08: 5~8 slpm constant bleed
15: 10~15 slpm constant bleed
*at 80 psig N2

Vacuum Connection

MV4: 1/4" VFS male
FV4: 1/4" VFS female
TW4: 1/4" tube weld

Ordering Example

VVG2S - PC - A - MV4 - MV8 - MV4 - 05

1 - 2 - 3

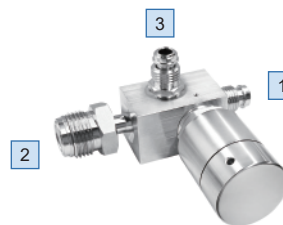

All-Welded Check Valve VUCV Series

Product Feature

- All-welded design body with minimal dead space
- Cracking pressure less than 2 psig (0.13bar)
- The product is fabricated in compliance with the VS001B process specification
- 316L SS Materials for ultra-high purity grackle
- Strong durability as well as corrosion resistance for long cycle life
- Elgiloy® spring material with free noise in the process of using



Technical Data

Working Pressure :	3000 psig (200bar)
Opening pressure:	<2 psig (0.13bar)
Working Temperature :	-10~80°C
Material	
Body:	SS 316L
Sprting:	Elgiloy®
O-ring :	FKM (standard) EPDM / FFKM (optional)
Flow Capacity :	Cv=0.55 (1/4")
	Cv=0.70 (1/2")

Dimensions (mm)

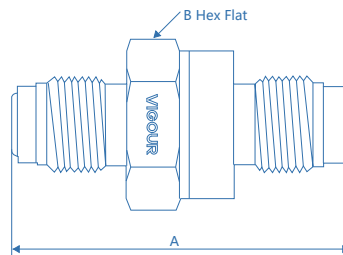

End Conections	Dimensions (mm)	
	A	B
1/4" VFS male	45.7	22
1/2" VFS male	52.5	27

Ordering Information

VUCV - S - MV4 - MV4 - E

Material

S: 316L
H: Hastelloy® C276

Inlets / Outlets

MV4: 1/4"VFS male
MV8: 1/2"VFS male

Seal Materials

None: FKM
E: EPDM
K: Kalrez® (FFKM)

Check Valve VCVH Series

Product Feature

- Compact check valve
- O-ring Materials: FKM standard, EPDM or FFKM optional
- Working pressure: Max. 6000 psig (413 bar)
- The product is fabricated in compliance with the VS001B process specification
- Opening pressure: 1/3psi / 1psi
- Inlet/outlet connection: VFS fitting



Typical Applications

- Designed for instrument panels and systems
- Hydrogen energy
- High-flow applications

Technical Data

Working pressure:	Max. 6000 psig (413 bar)
Opening pressure:	1/3psi / 1psi
O-ring:	FKM (standard) EPDM / FFKM (optional)
Leakage rate:	Bubble-tight
Flow capacity:	1/4" Cv=0.67, 1/2" Cv=1.8, 3/4" Cv=4.7

Dimensions (mm)

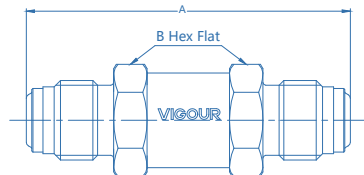

Ordering Number	Dimensions (mm)	
	A	B
VCVH-S-MV4-MV4	58.2	17.4
VCVH-S-MV8-MV8	68.3	25.4
VCVH-S-MV12-MV12	96	41.2

Nominal opening pressure	Opening pressure range	Reset pressure
1/3 (0.03)	3 (0.21) under	6 (0.42) under
1 (0.07)	4 (0.28) under	5 (0.35)
5 (0.35)	3~9 (0.21~0.63)	2 (0.14)
10 (0.69)	7~15 (0.49~1.1)	3 (0.21)
25 (1.8)	20~30 (1.4~2.1)	17 (1.21)

Flowchart

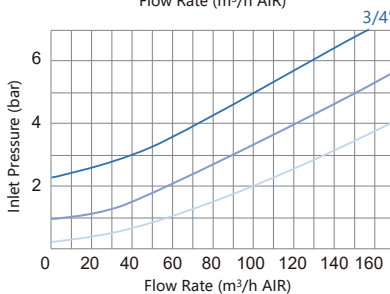
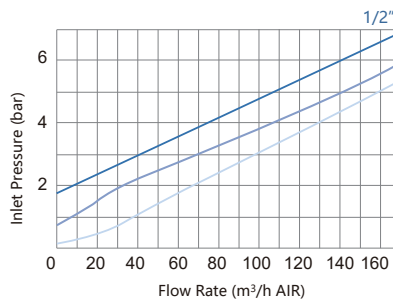
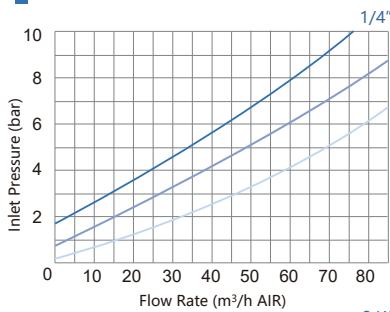

*Opening pressure: — 1 psig (0.07bar)
— 10 psig (0.69bar)
— 25 psig (1.8bar)

The rating is based on fluorocarbon FKM seals.

Material	316 SS	
Series	MV4 / MV8	MV12
Temperature, °C (°F)	Work pressure, psig (bar)	
-28 (-20) to 37 (100)	6000 (413)*	5000 (344)*
93 (200)	5160 (355)	4290 (295)
121 (250)	4910 (338)	4080 (281)
148 (300)	4660 (321)	3875 (266)
204 (400)	4280 (294)	3560 (245)

*For detailed information on the pressure ratings of valves with compression tube fitting end connections, refer to the VIGOUR Compression Tube Data.

*The pressure rating may be limited by the end connection.

Ordering Information

VCVH - S - MV4 - MV4 - E - 1

Materials

S: 316L

Inlet / Outlet Connection

MV4: 1/4" VFS male
MV8: 1/2" VFS male
MV12: 3/4" VFS male

Opening pressure

1: 1psi
1/3: 1/3 psi

O-ring

None: FKM
E: EPDM
K: FFKM

Adjustable Check Valve VCA Series

Product Feature

- Check Valve with Adjustable Pressure
- Set the opening pressure via the adjusting screw
- The locking screw keeps the setting
- The product is fabricated in compliance with the VS001B process specification
- 316 stainless steel and brass materials



Typical Applications

- Used for overpressure discharge after the pressure regulating valve of the special gas equipment.
- Scenarios of one-way circulation that require pressure setting

Technical Data

Working pressure:	Max. 3000 psig (206 bar)
Opening pressure:	3~350psi
Parent material:	see ordering info
Inlet/outlet connection:	see ordering info
O-ring:	FKM (Standard) EPDM / FFKM (optional)
Leakage rate:	Bubble-tight

Flowchart

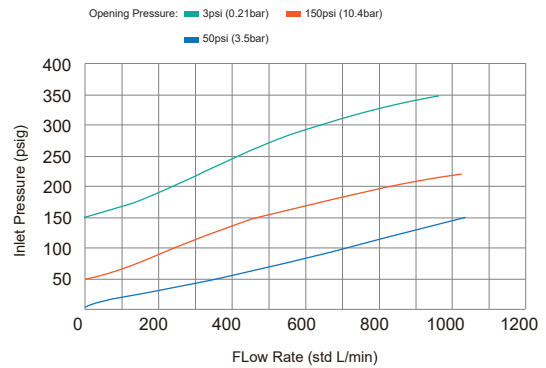

Dimensions (mm)

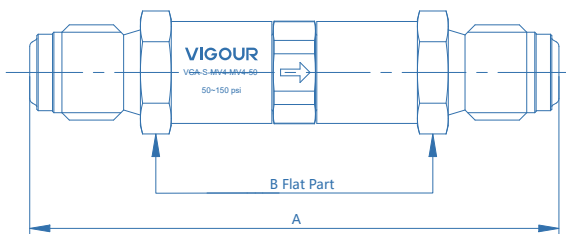

Connections	Dimensions (mm)	
	A	B
04	82	15.8
6M		
8M		
M4		
MV4		

Ordering Information

VCA - S - MV4 - MV4 - 50 - E

Materials

S: 316L

Inlet / Outlet

- 04: 1/4" Tube fitting
- 6M: 6mm Tube fitting
- 8M: 8mm Tube fitting
- M4: 1/4" NPT male
- MV4: 1/4" VFS male

O-ring

- None: FKM
- E: EPDM
- K: FFKM

Opening pressure

- 3: 3~50psi
- 50: 50~150psi
- 150: 150~350psi

Product Features

- Ultra high purity gas stick for all gas delivery systems
100TG: ≤30 slpm delivery 1/4" VFS
200TG: ≤300 slpm delivery 3/8" VFS
300TG: ≤600 slpm delivery 1/2" VFS
- The product is fabricated in compliance with the VS001B process specification
- High control accuracy
- All connections welded or VFS
- Manual or pneumatic diaphragm valve option
- 100% Helium-leak-tested

Technical Data

Inlet pressure P1:	300 psig (20bar)
Outlet pressure P2:	Vac to 10/30/60/100/150 psig (1/2/4/7/10bar)
Diaphragm valve materials	
body:	316L
Valve seat:	PCTFE
Diaphragm:	Elgiloy®
Regulator materials	
body:	316L / 316L secondary remelt
Valve seat:	PCTFE
Diaphragm:	Hastelloy® C276
Leak rate: (to atmosphere)	1x10 ⁻⁹ mbar-l/s He
(via seat)	1x10 ⁻⁸ mbar-l/s He



Dimensions (mm)

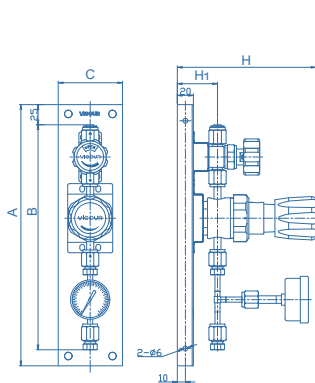

VUP-100TG (A Type)

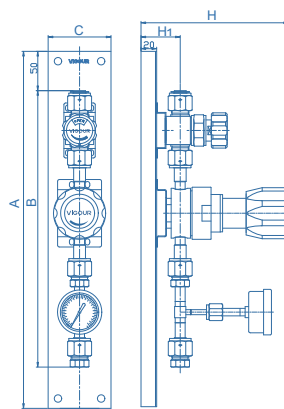

VUP-200TG / VUP-300TG (A Type)

Type	Panel Thickness mm	Ordering Number	Dimensions, mm				
			A	B	C	H	H1
100TG	20	VUP-100TG-A	325	280	80	172.5	50
200TG	20	VUP-200TG-A	455	352.4	80	188	50
300TG	20	VUP-300TG-A	455	349.2	80	188	50

Gas Stick VUP Series

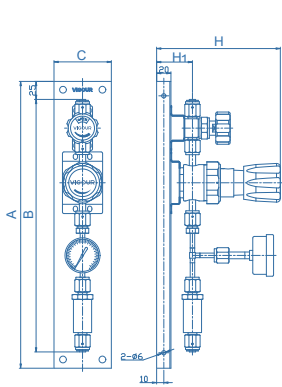

VUP-100TG (B Type)

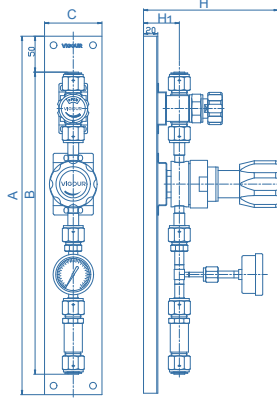

VUP-200TG / VUP-300TG (B Type)

Type	Panel Thickness mm	Ordering Number	Dimensions, mm				
			A	B	C	H	H1
100TG	20	VUP-100TG-B	400	352.3	80	172.5	50
200TG	20	VUP-200TG-B	500	421.4	80	188	50
300TG	20	VUP-300TG-B	500	418.2	80	188	50

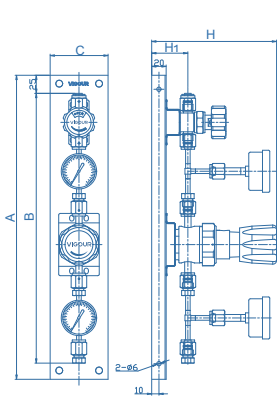

VUP-100TG (C Type)

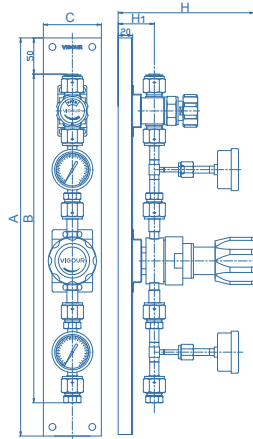

VUP-200TG / VUP-300TG (C Type)

Type	Panel Thickness mm	Ordering Number	Dimensions, mm				
			A	B	C	H	H1
100TG	20	VUP-100TG-C	420	372.6	80	172.5	50
200TG	20	VUP-200TG-C	550	454.1	80	188	50
300TG	20	VUP-300TG-C	550	447.7	80	188	50

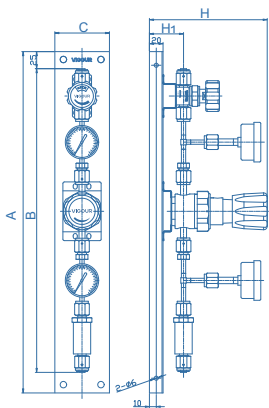

VUP-100TG (D Type)

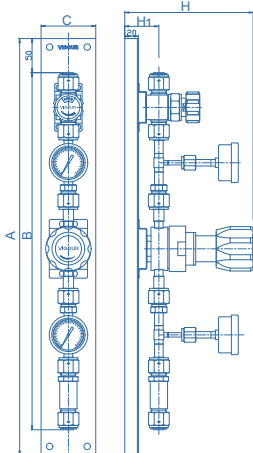

VUP-200TG / VUP-300TG (D Type)

Type	Panel Thickness mm	Ordering Number	Dimensions, mm				
			A	B	C	H	H1
100TG	20	VUP-100TG-D	500	444.9	80	172.5	50
200TG	20	VUP-200TG-D	610	523.1	80	188	50
300TG	20	VUP-300TG-D	610	516.7	80	188	50

Ordering Information

VUP - 100TG - D - 20 - 10 - FV4 - P - P - FV4 - F - PC

Series

100TG: ≤30 slpm delivery 1/4"VFS
 200TG: ≤300 slpm delivery 3/8"VFS
 300TG: ≤600 slpm delivery 1/2"VFS

Type

A: Single gauge, No filter included
 B: Single gauge, included filter
 C: Dual gauge, No filter included
 D: Dual gauge, included filter
 E: Inlet and Outlet diaphragm valves

Inlet Pressure P1

20: 300 psig

Outlet Pressure P2

V1: Vac to 10 psig
 V2: Vac to 30 psig
 V4: Vac to 60 psig
 V7: Vac to 100 psig
 V10: Vac to 150 psig
 1: to 10 psig
 2: to 30 psig
 4: to 60 psig
 7: to 100 psig
 10: to 150 psig

Inlet Valve

None: No inlet valve
 MV4: 1/4"VFS male
 FV4: 1/4"VFS female
 MV8: 1/2"VFS male
 FV8: 1/2"VFS female

Diaphragm Valve Option

None: Manual valve
 PC: Pneumatic valve
 (normally closed)

Outlet Option

None: Without
 F: Filter (0.003 μm)

Outlet Valve

MV4: 1/4"VFS male
 FV4: 1/4"VFS female
 MV8: 1/2"VFS male
 FV8: 1/2"VFS female

Outlet Pressure Indication

None: No inlet gauge
 P: Pressure gauge
 K: Contact pressure gauge
 PT: Pressure mitter transmitter

Inlet Pressure Indication

None: No outlet gauge
 P: Pressure gauge
 K: Contact pressure gauge
 PT: Pressure transducer

Filter VUF Series

Product Feature

- The VUF series is an in-line gas filter designed for ultra-high purity gas filtration applications
- Filter material: PTFE, Shell material: 316L
- High particle removal efficiency
- Excellent chemical compatibility
- The product is fabricated in compliance with the VS001B process specification
- Filtration accuracy: 0.003 μ m
- High temperature and high pressure working environment
- Compact and easy to install
- 100% helium leak test



Vacuum and Flow Specification

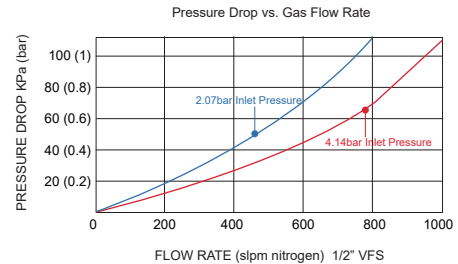
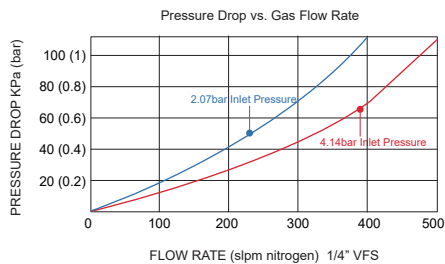
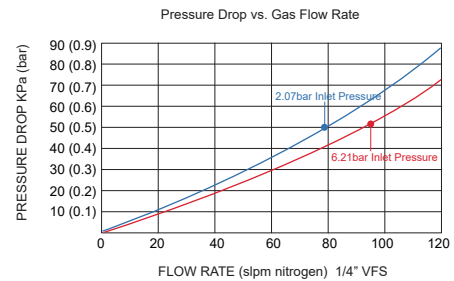
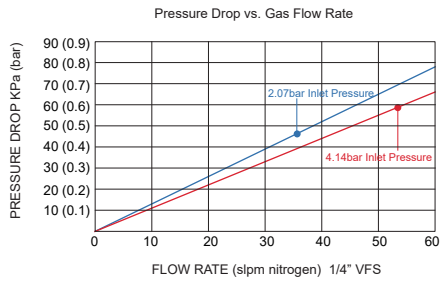

Dimensions (mm)

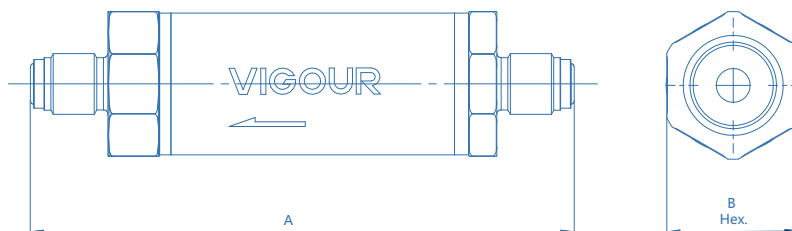

Ordering Number	Dimensions (mm)	
	A	B
VUF-P-MV4-MV4-60	84.1	18.9
VUF-P-MV4-FV4-60	88.9	18.9
VUF-P-MV4-MV4-120	127	25.8
VUF-P-MV4-MV4-500	127	33.8
VUF-P-MV4-FV4-500	141.2	33.8
VUF-P-MV8-MV8-120	133.4	25.8
VUF-P-MV8-MV8-1000	127	33.8

Ordering Information

Ordering Number	Shell Material	Filter Material	Inlet Connection	Outlet Connection	Max. Flow Rate
VUF-P-MV4-MV4-60	316L	PTFE	1/4"VFS male	1/4"VFS male	0~60 slpm
VUF-P-MV4-FV4-60	316L	PTFE	1/4"VFS male	1/4"VFS female	0~60 slpm
VUF-P-MV4-MV4-120	316L	PTFE	1/4"VFS male	1/4"VFS male	0~120 slpm
VUF-P-MV4-MV4-500	316L	PTFE	1/4"VFS male	1/4"VFS male	0~500 slpm
VUF-P-MV4-FV4-500	316L	PTFE	1/4"VFS male	1/4"VFS female	0~500 slpm
VUF-P-MV8-MV8-120	316L	PTFE	1/2"VFS male	1/2"VFS male	0~120 slpm
VUF-P-MV8-MV8-1000	316L	PTFE	1/2"VFS male	1/2"VFS female	0~1000 slpm

Filter

VFH Series

Product Feature

- The VFH Series is an In-Line filtration device
- Filter material: 316L
- The product is fabricated in compliance with the VS001B process specification
- Compact size and lightweight
- Outstanding chemical compatibility
- Tested for use with oxygen



In-line Type

Technical Data

Working Pressure:	2350 psig (162bar)
Working Temperature:	-10~100°C
Material	
Body:	SS 316L
Filter Element:	SS 316L
Gasket:	SS 316L / PTFE
End Connection:	VFS Threaded Fitting

Dimensions (mm)

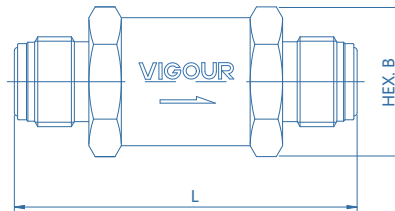

End Connections	Dimensions (mm)	
	L	B
1/4" VFS male	79.3	32
1/2" VFS male	84.4	32

Ordering Information

VFH - S - MV4 - MV4 - 2

Material S: 316L	Filtering Accuracy 0.5: 0.5 µm 2: 2 µm 5: 5 µm 10: 10 µm 20: 20 µm 40: 40 µm 70: 70 µm
Inlets / Outlets MV4: 1/4" VFS male MV8: 1/2" VFS male	

Product Feature

- All-metal filter
- Compact design
- Protect sensitive gas componers from particle damage
- Zntegrate into the gas system with out adding length
- Retain particles down to 0.3µm
- The product is fabricated in compliance with the VS001B process specification
- Filtration accuracy: 0.003µm
- Dired with high purity nitrogen
- Fits in place of standard 1/4", 1/2" VFS Gasket



Flow Rata

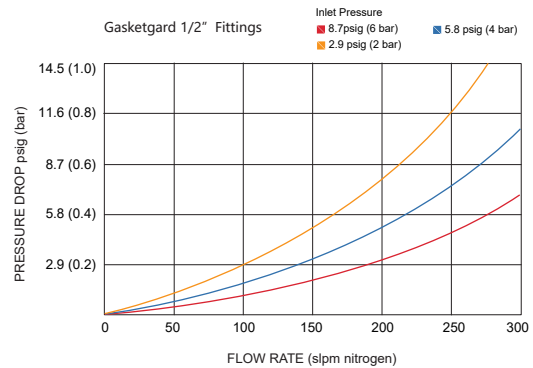
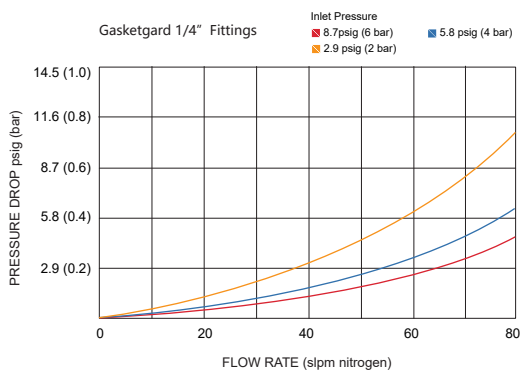

Dimensions (mm)

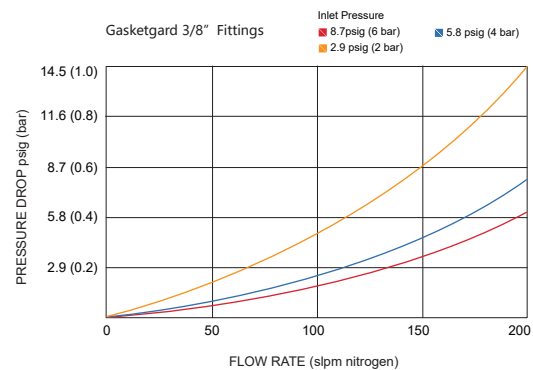
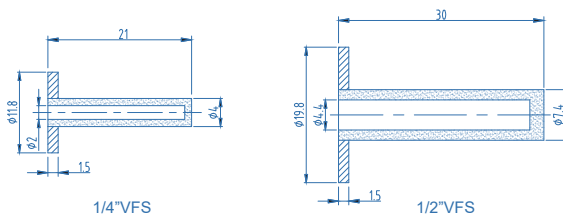

Ordering Information

VUGF - GK - G4

Gasket Option

GK: Gasket

GKR: Gasket Retainer Assembly

Option

G4: 1/4" VFS Gasket

G6: 3/8" VFS Gasket

G8: 1/2" VFS Gasket

Flow Switch VEFS1 Series

Product Feature

- Flow thru design free of deadlegs or unswept zones
- 316L secondary remelt
- Vacuum to 3,500 psig (241 bar)

Technical Data

Source pressure:	vacuum to 3500 psig (241 bar)
Flow trip reference points:	25/50/100 slpm (N2 at 100 psig)
Accuracy:	±10%
Installation orientation:	Vertical within 8° and inlet port at the bottom
Operating temperature:	-10~175°F (-23~80°C)
Body:	316L secondary remelt
Inlet / Outlet:	1/4" tube weld / VFS fitting
Leakage (Outboard) :	<1x10 ⁻⁹ mbar l/s He
Reed Switch —	
Type:	SPDT, 3 wire / 2 position
Power:	30VDC / 3W max
Switching current:	0.2A max
Carrying current:	0.5A max
Initial contact resistance:	0.1 Ohm max
Cable length:	3m
Wire gauge:	24AWG



Cable —
Blue: common
Brown: normally closed
Black: normally open

Dimensions (mm)

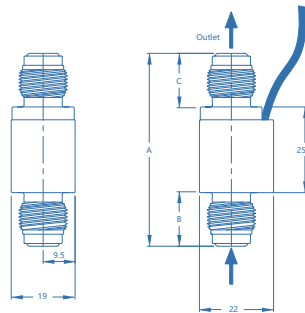

Connections (Inlet-Outlet)	Dimensions (mm)		
	A	B	C
MV4-MV4	57.2	15.9	15.9
FV4-FV4	101.4	38	38
TW4-TW4	57.2	15.9	15.9
MV4-FV4	79.3	15.9	38
MV4-TW4	57.2	15.9	15.9
FV4-MV4	79.3	38	15.9
FV4-TW4	79.3	38	15.9
TW4-MV4	57.2	15.9	15.9
TW4-FV4	79.3	15.9	38

Ordering Information

VEFS1 - SLV - MV4 - MV4 - 100 - P

Material

SLV: 316L secondary remelt

Inlet / Outlet

MV4: 1/4"VFS male
FV4: 1/4"VFS female
TW4: 1/4"tube weld

Process Specification

P: VS001A

* For details, please refer to the appendix.

Flow

025: 25 slpm
050: 50 slpm
100: 100 slpm

! The flow rate specified in the standard is measured with nitrogen at an inlet pressure of 100 psig and a temperature of 20°C. If operating conditions deviate from the standard, conversion to the actual operating flow rate is required. Please refer to Page 117 for the conversion!

Product Feature

- Flow switch for high flow
- Available with horizontal or vertical main line
- Minimal pressure drop through device
- SS 316L material

Technical Data

Source pressure:	vacuum to 3500 psig (241 bar) 1/2" vacuum to 3000 psig (207 bar) 3/4" vacuum to 2200 psig (152 bar) 1"
Flow trip reference points:	see ordering info
Accuracy:	±20%
Operating temperature:	-10~175°F (-23~80°C)
Body:	SS 316L
Inlet / Outlet:	1/2" 3/4" tube weld / VFS fitting, 1" tube weld
Leakage (Outboard) :	<1x10 ⁻⁹ mbar l/s He
Reed Switch	—
Type:	SPDT, 3 wire / 2 position
Power:	30VDC / 3W max
Switching current:	0.2A max
Carrying current:	0.5A max
Initial contact resistance:	0.1 Ohm max
Cable length:	3m
Wire gauge:	24AWG



Cable	—
Blue:	common
Brown:	normally closed
Black:	normally open

Dimensions (mm)

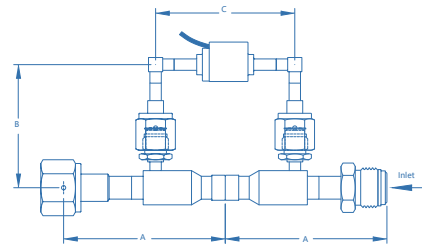

Connections (Inlet-Outlet)	Dimensions (mm)			C
	A	B		
		Horizontal	Vertical	
FV8-MV8	90.2	115.6	68.9	77.8
TW8-TW8	65.8	115.6	68.9	77.8
FV12-MV12	140	138.2	91.2	77.8
TW12	89.6	138.2	91.2	77.8
TW16	99.1	141.5	94.5	77.8

Ordering Information

VEFS2 - S - H - FV8 - MV8 - 225 - P

Material	S: 316L SS
Position	H: Horizontal V: Vertical
Inlet / Outlet	FV8: 1/2"VFS(F) MV8: 1/2"VFS(M) TW8: 1/2"tube weld FV12: 3/4"VFS(F) MV12: 3/4"VFS(M) TW12: 3/4"tube weld TW16: 1"tube weld

Flow

N2 at 100 psig
1/2" —
225: 225 slpm
350: 350 slpm
500: 500 slpm
950: 950 slpm
3/4" —
1100: 1100 slpm
1650: 1650 slpm
2600: 2600 slpm
1" —
3000: 3000 slpm
4000: 4000 slpm

Process Specification

P: VS001A

* For details, please refer to the appendix.

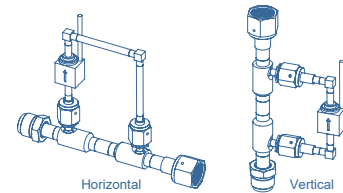

! The flow rate specified in the standard is measured with nitrogen at an inlet pressure of 100 psig and a temperature of 20°C. If operating conditions deviate from the standard, conversion to the actual operating flow rate is required. Please refer to Page 117 for the conversion!

Flow Switch

Working Flow Conversion Formula

Conversion Formula

The test flow rate under standard specifications is the value of nitrogen at an inlet pressure of 100 psig and 20°C. If deviating from standard operating conditions, conversion to the actual working flow rate is required.

1. Pressure Conversion Factor: $F_p = \sqrt{(OP/114.7)}$ OP: Operating Pressure (Absolute Pressure) psia
2. Gas Conversion Factor: $F_g = \sqrt{(28/MW)}$ MW: Molar Mass of the Gas Used, g/mol
3. Temperature Conversion Factor: $F_t = \sqrt{(293/OT)}$ OT: Operating Temperature, °C+273

Conversion Example

If hydrogen (molecular weight 2) is used at a pressure of 72.5 psig (gauge pressure) and a temperature of 25 °C, and a flow switch with a standard flow rate of 500 SLPM (VEFS2-S---500) is selected, the conversion is as follows:

1. Pressure Conversion Factor: $F_p = \sqrt{((72.5+14.5)/114.7)} = 0.871$
2. Gas Conversion Factor: $F_g = \sqrt{(28/2)} = 3.742$
3. Temperature Conversion Factor: $F_t = \sqrt{(293/298)} = 0.992$

The actual working flow rate is: $500 \text{ (L/min)} \times 0.871 \times 3.742 \times 0.992 = 1616.6 \text{ (L/min)}$

General Information



Materials

Material	Ordering Number Designator	Specification
Glands, Bodies, and Nuts		
316L stainless steel	Standard	Bar stock: ASME SA479, ASTM A276 Forgings: ASME A182
316L secondary remelt stainless steel	-SLV	Bar stock: ASME SA479, ASTM A276 Forgings: ASME A182
Gaskets		
Nickel	-NI	ASTM B162
316L stainless steel	Standard	ASTM A240, ASTM A167

* The product is fabricated in compliance with the VS001A process specification

Dimensions

- Dimensions are for reference only and may change without prior notice
- The D1 dimension refers to the smallest nominal inside diameter of the part

Pressure Ratings

- Ratings are based upon tests conducted using VFS assemblies
- All ratings comply with calculations per ANSI Code for Pressure Piping B31.3
- To determine pressure ratings in accordance with ANSI B31.3, multiply psig rating by 0.94
- Ratings determined at ambient temperature

Components	Material	Temperature, °F (°C)
Fittings	316L stainless steel	1000 (537)
	316L secondary remelt stainless steel	1000 (537)
Gaskets	316L stainless steel	1000 (537)
	Nickel	600 (315)

Testing

The VFS assembly with silver plating has been helium leak tested to a rate of 4×10^{-9} mbar l/s He and the unplated gasket to a rate of 4×10^{-11} mbar l/s He without leakage.

Face Seal Fitting VVR Series

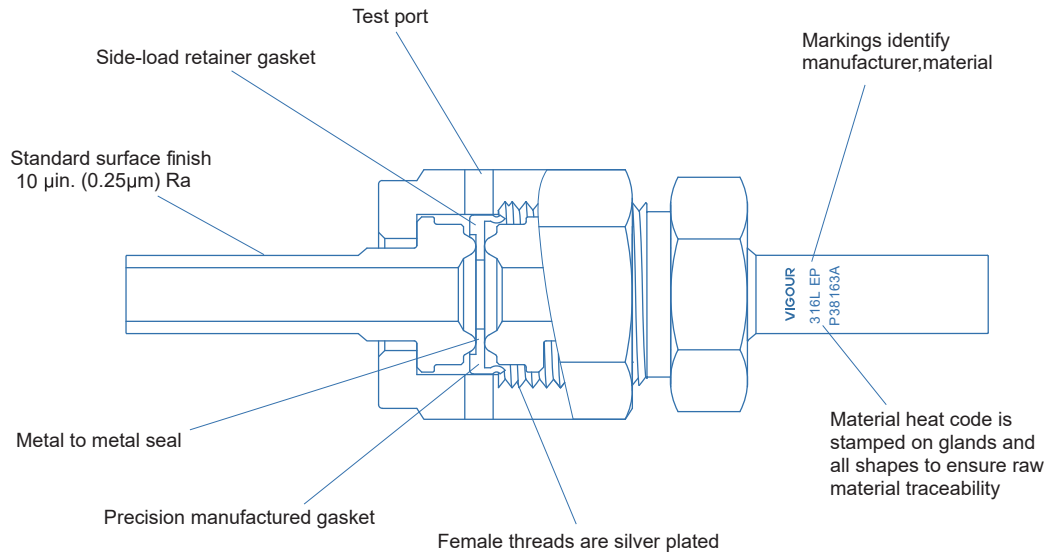

Typical VFS Assemblies

VFS assemblies are made up of four or five basic components.

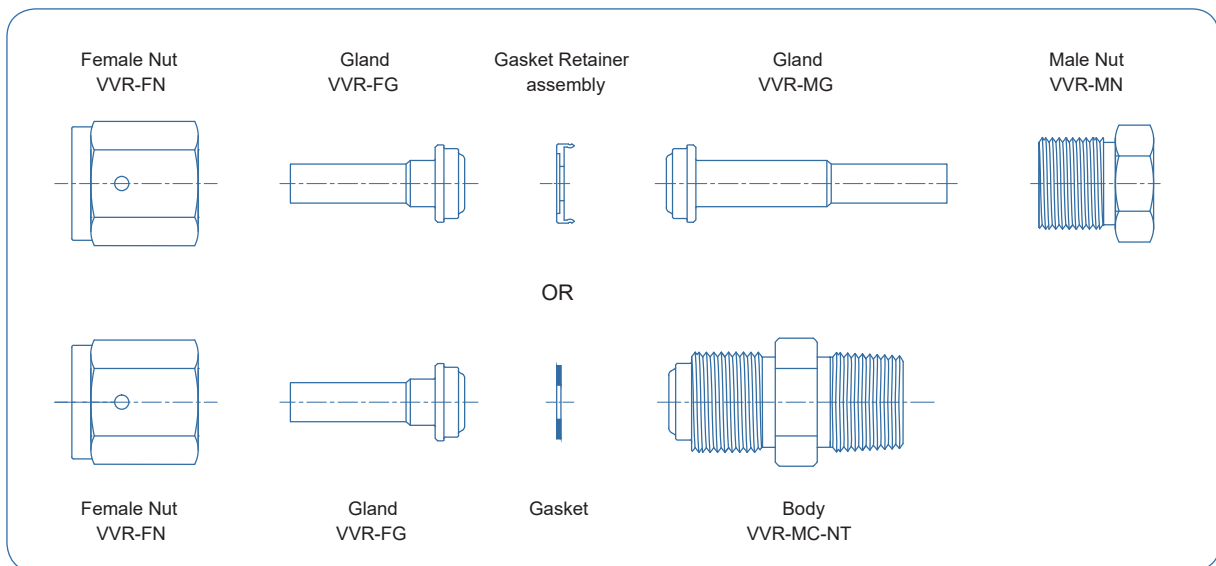

Glands

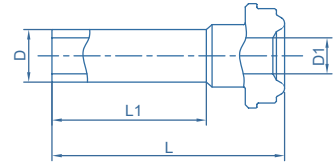

Short Tube Butt Weld

D Tube OD in.	Wall Thickness in.	VFS Size in.	Material	Ordering Number	Dimensions, in.(mm)			Working Pressure psig (bar)
					L1	D1	L	
1/8	0.028	1/8	316L	VVR-FG2-TB2 ①	0.75	0.07	1.08	8500
			316L secondary remelt	VVR-FG2-TB2-SLV ①	(19.1)	(1.8)	(27.4)	(585)
1/4	0.035	1/4	316L	VVR-FG4-TB4	0.75	0.18	1.10	5100
			316L secondary remelt	VVR-FG4-TB4-SLV	(19.1)	(4.6)	(27.9)	(351)
1/4	0.035	1/4	316L	VVR-FG4-TB4-L18	0.38	0.18	0.72	5100
			316L secondary remelt	VVR-FG4-TB4-L18-SLV	(9.6)	(4.6)	(18.3)	(351)
1/4	0.035	1/4	316L	VVR-FG4-TB4-L15	0.25	0.18	0.60	5100
			316L secondary remelt	VVR-FG4-TB4-L15-SLV	(6.4)	(4.6)	(15.2)	(351)
1/4	0.035	1/2	316L	VVR-FG8-TB4	0.75	0.18	1.12	4300
			316L secondary remelt	VVR-FG8-TB4-SLV	(19.1)	(4.6)	(28.4)	(296)
1/4	0.035	1/2	316L	VVR-FG8-TB4-L15	0.25	0.18	0.62	4300
			316L secondary remelt	VVR-FG8-TB4-L15-SLV	(19.1)	(4.6)	(15.7)	(296)
1/4	0.035	1/2	316L	VVR-FG8-TB4-L19	0.75	0.18	0.76	4300
			316L secondary remelt	VVR-FG8-TB4-L19-SLV	(19.1)	(4.6)	(19.4)	(296)
3/8	0.035	1/2	316L	VVR-FG8-TB6	0.75	0.31	1.12	3300
			316L secondary remelt	VVR-FG8-TB6-SLV	(19.1)	(7.9)	(28.4)	(227)
3/8	0.035	1/2	316L	VVR-FG8-TB6-L15	0.25	0.31	0.62	3300
			316L secondary remelt	VVR-FG8-TB6-L15-SLV	(6.4)	(7.9)	(15.7)	(227)
1/2	0.049	1/2	316L	VVR-FG8-TB8	0.75	0.40	1.12	3700
			316L secondary remelt	VVR-FG8-TB8-SLV	(19.1)	(10.2)	(28.4)	(254)
1/2	0.049	1/2	316L	VVR-FG8-TB8-L18	0.38	0.40	0.74	3700
			316L secondary remelt	VVR-FG8-TB8-L18-SLV	(9.6)	(10.2)	(18.8)	(254)
1/2	0.049	1/2	316L	VVR-FG8-TB8-L15	0.25	0.40	0.62	3700
			316L secondary remelt	VVR-FG8-TB8-L15-SLV	(6.4)	(10.2)	(15.7)	(254)
3/4	0.065	3/4	316L	VVR-FG12-TB12	0.81	0.62	1.25	2400
			316L secondary remelt	VVR-FG12-TB12-SLV	(20.6)	(15.7)	(32)	(165)
1	0.065	1	316L	VVR-FG16-TB16	0.75	0.87	1.51	1900
			316L secondary remelt	VVR-FG16-TB16-SLV	(19.1)	(22.1)	(38.6)	(130)

① not design for gasket retainer assembly

* To order fittings manufactured for Surface Finish Ra(Average)<0.4 add BA to the ordering number. Example: VVR-FG4-TB4-BA

* Default process spec: VS001B. If ordering VS001A-spec fittings for VIGOUR Ultra-High Purity Products, add "P" to the order number. Example: VVR-FG4-TB4-P

Face Seal Fitting

VVR Series

Glands

Long Tube Butt Weld

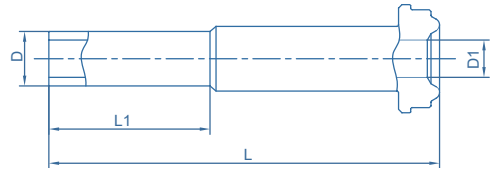

D Tube OD in.	Wall Thickness in.	VFS Size in.	Material	Ordering Number	Dimensions, in.(mm)			Working Pressure psig (bar)
					L1	D1	L	
1/8	0.028	1/8	316L	VVR-MG2-TB2 ①	0.75	0.07	1.42	8500
			316L secondary remelt	VVR-MG2-TB2-SLV ①	(19.1)	(1.8)	(36.1)	(585)
1/8	0.022	1/4	316L	VVR-MG4-TB2	0.28	0.18	1.31	6400
			316L secondary remelt	VVR-MG4-TB2-SLV	(7.1)	(4.6)	(33.3)	(440)
1/4	0.035	1/4	316L	VVR-MG4-TB4	0.75	0.18	1.70	5100
			316L secondary remelt	VVR-MG4-TB4-SLV	(19.1)	(4.6)	(43.2)	(351)
1/4	0.035	1/4	316L	VVR-MG4-TB4-L33	0.38	0.18	1.32	5100
			316L secondary remelt	VVR-MG4-TB4-L33-SLV	(9.6)	(4.6)	(33.5)	(351)
1/4	0.035	1/4	316L	VVR-MG4-TB4-L30	0.25	0.18	1.20	5100
			316L secondary remelt	VVR-MG4-TB4-L30-SLV	(6.4)	(4.6)	(30.5)	(351)
1/4	0.035	1/2	316L	VVR-MG8-TB4	0.75	0.18	1.79	4300
			316L secondary remelt	VVR-MG8-TB4-SLV	(19.1)	(4.6)	(45.5)	(296)
1/4	0.035	1/2	316L	VVR-MG8-TB4-L32	0.75	0.18	1.28	4300
			316L secondary remelt	VVR-MG8-TB4-L32-SLV	(19.1)	(4.6)	(32.7)	(296)
1/4	0.035	1/2	316L	VVR-MG8-TB4-L37	0.75	0.18	1.47	4300
			316L secondary remelt	VVR-MG8-TB4-L37-SLV	(19.1)	(4.6)	(37.4)	(296)
3/8	0.035	1/2	316L	VVR-MG8-TB6	0.75	0.31	1.79	3300
			316L secondary remelt	VVR-MG8-TB6-SLV	(19.1)	(7.9)	(45.5)	(227)
3/8	0.035	1/2	316L	VVR-MG8-TB6-L32	0.25	0.31	1.29	3300
			316L secondary remelt	VVR-MG8-TB6-L32-SLV	(6.4)	(7.9)	(32.8)	(227)
1/2	0.049	1/2	316L	VVR-MG8-TB8	0.75	0.40	1.79	3500
			316L secondary remelt	VVR-MG8-TB8-SLV	(19.1)	(10.2)	(45.5)	(241)
1/2	0.049	1/2	316L	VVR-MG8-TB8-L35	0.38	0.40	1.41	3500
			316L secondary remelt	VVR-MG8-TB8-L35-SLV	(9.6)	(10.2)	(35.8)	(241)
1/2	0.049	1/2	316L	VVR-MG8-TB8-L32	0.25	0.40	1.29	3500
			316L secondary remelt	VVR-MG8-TB8-L32-SLV	(6.4)	(10.2)	(32.8)	(241)
3/4	0.065	3/4	316L	VVR-MG12-TB12	0.75	0.65	2.03	2400
			316L secondary remelt	VVR-MG12-TB12-SLV	(19.1)	(16.5)	(51.6)	(165)
1	0.065	1	316L	VVR-MG16-TB16	0.75	0.87	2.32	2400
			316L secondary remelt	VVR-MG16-TB16-SLV	(19.1)	(22.1)	(58.9)	(165)

① not design for gasket retainer assembly

* To order fittings manufactured for Surface Finish Ra(Average)<0.4 add BA to the ordering number. Example: VVR-MG4-TB4-BA

* Default process spec: VS001B. If ordering VS001A-spec fittings for VIGOUR Ultra-High Purity Products, add "P" to the order number. Example: VVR-MG4-TB4-P

Male Nut

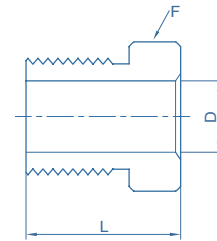

VFS Size in.	Ordering Number	Material	F Hex Flat	Dimensions, in.(mm)	
				L	D
1/8	VVR-MN2	316L	3/8	0.50 (12.7)	0.21 (5.3)
1/4	VVR-MN4		5/8	0.71 (18.0)	0.36 (9.1)
1/2	VVR-MN8		15/16	0.81 (20.6)	0.61 (15.5)
3/4	VVR-MN12		1-5/16	1.00 (25.4)	0.89 (22.6)
1	VVR-MN16		1-5/8	1.19 (30.2)	1.20 (30.5)

* Default process spec: VS001B.

Female Nut

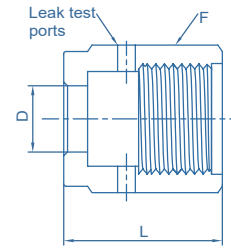

VFS Size in.	Ordering Number	Material	F Hex Flat	Dimensions, in.(mm)	
				L	D
1/8	VVR-FN2	316L	7/16	0.53 (13.5)	0.21 (5.3)
1/4	VVR-FN4		3/4	0.81 (20.6)	0.36 (9.1)
1/2	VVR-FN8		1-1/16	0.88 (22.4)	0.61 (15.5)
3/4	VVR-FN12		1-1/2	1.12 (28.4)	0.89 (22.6)
1	VVR-FN16		1-3/4	1.34 (34.0)	1.20 (30.5)

* Default process spec: VS001B.

Coupling

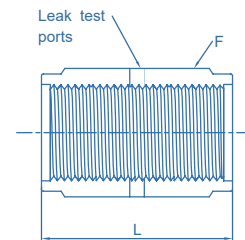

VFS Size in.	Material	Ordering Number	Dimensions, in.(mm)	
			L	F
1/8	316L	VVR-FU2	0.66 (16.8)	7/16
1/4		VVR-FU4	1.19 (30.2)	3/4
1/2		VVR-FU8	1.31 (33.3)	1-1/16
3/4		VVR-FU12	1.68 (42.7)	1-1/2
1		VVR-FU16	2.04 (51.8)	1-3/4

* Default process spec: VS001B.

Face Seal Fitting

VVR Series

Gaskets

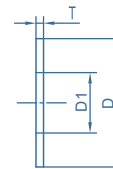

VFS Size in.	Ordering Number	Material	Dimensions, in.(mm)		
			D1	T	D
1/8	VVR-GK-G2	316L	0.09 (2.3)	0.028 (0.7)	0.26 (6.6)
	VVR-GK-G2-NI	Nickel			
1/4	VVR-GK-G4	316L	0.22 (5.6)	0.028 (0.7)	0.47 (11.9)
	VVR-GK-G4-NI	Nickel			
	VVR-GK-G4-SP	Silver-plated			
1/2	VVR-GK-G8	316L	0.44 (11.2)	0.028 (0.7)	0.78 (19.8)
	VVR-GK-G8-NI	Nickel			
3/4	VVR-GK-G12	316L	0.66 (16.8)	0.028 (0.7)	1.14 (29.0)
	VVR-GK-G12-NI	Nickel			
	VVR-GK-G16	316L			
1	VVR-GK-G16-NI	Nickel	0.89 (22.6)	0.028 (0.7)	1.40 (35.6)

* Default process spec: VS001B.

Gasket Retainer Assembly

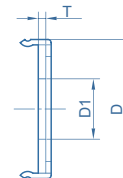

VFS Size in.	Ordering Number	Material	Dimensions, in.(mm)		
			D1	T	D
1/4	VVR-GKR-G4	316L	0.24 (6.1)	0.028 (0.7)	0.50 (12.7)
	VVR-GKR-G4-NI	Nickel			
	VVR-GKR-G4-SP	Silver-plated			
1/2	VVR-GKR-G8	316L	0.44 (11.2)	0.028 (0.7)	0.79 (20.1)
	VVR-GKR-G8-NI	Nickel			
	VVR-GKR-G8-SP	Silver-plated			
3/4	VVR-GKR-G12	316L	0.66 (16.8)	0.028 (0.7)	1.14 (29.0)
	VVR-GKR-G12-NI	Nickel			
1	VVR-GKR-G16	316L	0.89 (22.6)	0.028 (0.7)	1.40 (35.6)
	VVR-GKR-G16-NI	Nickel			

* Default process spec: VS001B.

Filter Gaskets

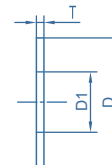

VFS Size in.	Ordering Number	Material	Dimensions, in.(mm)		
			D1	T	D
1/4	VVR-GKF-G4	316L	0.22 (5.6)	0.028 (0.7)	0.47 (11.9)
	VVR-GKRF-G4				
1/2	VVR-GKF-G8	316L	0.44 (11.2)	0.028 (0.7)	0.78 (19.8)
	VVR-GKRF-G8				

* Element Nominal Pore Size (Option) : 0.5µm / 2µm / 5µm / 10µm / 20µm / 60µm Ordering. Example: VVR-GKF-G4-0.5

* Default process spec: VS001B.

Flow-limiting Gaskets

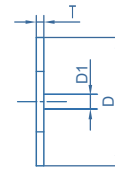

VFS Size in.	Ordering Number	Material	Dimensions, in.(mm)		
			D1	T	D
1/8	VVR-GK-G2-DM-*	316L	*	0.028 (0.7)	0.26 (6.6)
	VVR-GK-G2-NI-DM-*	Nickel	*		
1/4	VVR-GK-G4-DM-*	316L	*	0.028 (0.7)	0.47 (11.9)
	VVR-GK-G4-NI-DM-*	Nickel	*		
	VVR-GK-G4-12.7-DM-*	316L	*		
	VVR-GK-G4-12.7-NI-DM-*	Nickel	*		
1/2	VVR-GK-G8-DM-*	316L	*	0.028 (0.7)	0.78 (19.8)
	VVR-GK-G8-NI-DM-*	Nickel	*		
3/4	VVR-GK-G12-DM-*	316L	*	0.028 (0.7)	1.14 (29.0)
	VVR-GK-G12-NI-DM-*	Nickel	*		
1	VVR-GK-G16-DM-*	316L	*	0.028 (0.7)	1.40 (35.6)
	VVR-GK-G16-NI-DM-*	Nickel	*		

* Please consult the manufacturer for gasket size.

* Default process spec: VS001B.

Flow-limiting Gaskets Retainer Assembly

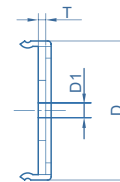

VFS Size in.	Ordering Number	Material	Dimensions, in.(mm)		
			D1	T	D
1/4	VVR-GKR-G4-DM-*	316L	*	0.028 (0.7)	0.50 (12.7)
	VVR-GKR-G4-NI-DM-*	Nickel	*		
1/2	VVR-GKR-G4-12.7-DM-*	316L	*	0.028 (0.7)	0.79 (20.1)
	VVR-GKR-G4-12.7-NI-DM-*	Nickel	*		
	VVR-GKR-G8-DM-*	316L	*		
3/4	VVR-GKR-G8-NI-DM-*	Nickel	*	0.028 (0.7)	1.14 (29.0)
	VVR-GKR-G12-DM-*	316L	*		
1	VVR-GKR-G12-NI-DM-*	Nickel	*	0.028 (0.7)	1.40 (35.6)
	VVR-GKR-G16-DM-*	316L	*		
	VVR-GKR-G16-NI-DM-*	Nickel	*		

* Please consult the manufacturer for gasket size.

* Default process spec: VS001B.

Face Seal Fitting VVR Series

Plug



VFS Size in.	Ordering Number	Corded Plug Ordering Number	Material	Dimensions, in.(mm)	
				F Hex Flat	L
1/8	VVR-P2 ^①		316L	3/8	0.68 (17.3)
1/4	VVR-P4 ^②	VVR-P4-L ^②		5/8	0.92 (23.4)
1/2	VVR-P8	VVR-P8-L		15/16	1.08 (27.4)
3/4	VVR-P12	VVR-P12-L		1-5/16	1.43 (36.3)
1	VVR-P16	VVR-P16-L		1-5/8	1.52 (38.6)

① Not designed for gasket retainer assembly.

② Also available as a rotatable plug. Ordering number: VVR-P8-R

* Default process spec: VS001B. If ordering VS001A-spec fittings for VIGOUR Ultra-High Purity Products, add "P" to the order number.

Example: VVR-P4-P

Cap



VFS Size in.	Ordering Number	Corded Plug Ordering Number	Material	Dimensions, in.(mm)		
				F Hex Flat	L	A
1/8	VVR-C2		316L	7/16	0.63 (16.0)	0.30 (7.6)
1/4	VVR-C4	VVR-C4-L		3/4	0.94 (23.9)	0.44 (11.2)
1/2	VVR-C8	VVR-C8-L		1-1/16	1.01 (25.6)	0.45 (11.4)
3/4	VVR-C12	VVR-C12-L		1-1/2	1.29 (32.8)	0.54 (13.7)
1	VVR-C16	VVR-C16-L		1-3/4	1.54 (39.1)	0.63 (16.0)

* Default process spec: VS001B.

Male NPT Connectors ^①

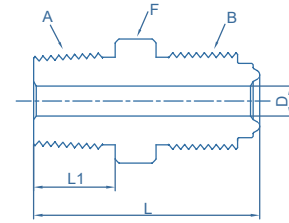

A NPT Size in.	B VFS Size in.	Material	Ordering Number	Dimensions, in.(mm)				Working Pressure psig (bar)	
				L	L1	D	F	NI	SS
1/16	1/8	316L	VVR-MC2-M1 ^①	1.07 (27.2)	0.38 (9.6)	0.09 (2.3) ^③	3/8	9000 (620)	9000 (620)
1/8	1/8		VVR-MC2-M2 ^②	1.07 (27.2)	0.38 (9.6)	0.09 (2.3) ^③	7/16	9000 (620)	9000 (620)
1/8	1/4		VVR-MC4-M2	1.31 (33.3)	0.38 (9.6)	0.18 (4.6)	5/8	10000 (689)	6400 (440)
1/4	1/4		VVR-MC4-M4	1.49 (37.8)	0.56 (14.2)	0.18 (4.6)	5/8	10000 (689)	6400 (440)
1/4	1/2		VVR-MC8-M4	1.65 (41.9)	0.56 (14.2)	0.28 (7.1) ^③	15/16	4300 (296)	2800 (192)
3/8	1/2		VVR-MC8-M6	1.65 (41.9)	0.56 (14.2)	0.38 (9.6)	15/16	4300 (296)	2800 (192)
1/2	1/2		VVR-MC8-M8	1.84 (46.7)	0.75 (19.1)	0.4 (10.2)	15/16	4300 (296)	2800 (192)
3/4	3/4		VVR-MC12-M12	2.19 (55.6)	0.75 (19.1)	0.62 (15.7)	1-5/16	3700 (254)	2400 (165)
1	1		VVR-MC16-M16	2.47 (62.7)	0.94 (23.9)	0.87 (22.1)	1-5/8	2400 (165)	3000 (206)

^① VFS components with fixed threads must remain stationary during installation.

These fitting connections should be assembled only to glands with rotating male or female threaded nuts.

^② Not designed for gasket retainer assembly

^③ May contain internal diameter transitions

* To order fittings manufactured for Surface finish Ra(Average)<0.4 add BA to the ordering number. Example: VVR-MC4-M4-BA

* Default process spec: VS001B. If ordering VS001A-spec fittings for VIGOUR Ultra-High Purity Products, add "P" to the order number. Example: VVR-MC4-M4-P

Female NPT Connectors ^①

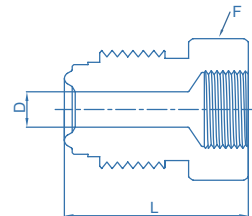

NPT Size in.	VFS Size in.	Material	Ordering Number	Dimensions, in.(mm)			Working Pressure psig (bar)	
				L	D	F flat	NI	SS
1/16	1/8	316L	VVR-MC2-F1 ^①	1.10 (27.9)	0.09 (2.3)	7/16	6700 (461)	6700 (461)
1/8	1/8		VVR-MC2-F2 ^②	1.19 (30.2)	0.09 (2.3)	9/16	6500 (447)	6500 (447)
1/8	1/4		VVR-MC4-F2	1.41 (35.8)	0.18 (4.6)	5/8	8000 (551)	8000 (551)
1/4	1/4		VVR-MC4-F4	1.54 (39.1)	0.18 (4.6)	3/4	6600 (454)	6600 (454)
3/8	1/2		VVR-MC8-F6	1.76 (44.7)	0.40 (10.2)	15/16	3500 (241)	4300 (296)
1/2	1/2		VVR-MC8-F8	1.99 (50.5)	0.40 (10.2)	1-1/16	3500 (241)	4300 (296)
3/4	3/4		VVR-MC12-F12	2.36 (59.9)	0.62 (15.7)	1-5/16	3000 (206)	3700 (254)
1	1		VVR-MC16-F16	2.51 (63.8)	0.87 (22.1)	1-5/8	2400 (165)	3000 (206)

^① VFS components with fixed threads must remain stationary during installation.

These fitting connections should be assembled only to glands with rotating male or female threaded nuts.

^② Not designed for gasket retainer assembly

* To order fittings manufactured for Surface finish Ra(Average)<0.4 add BA to the ordering number. Example: VVR-MC4-F4-BA

* Default process spec: VS001B. If ordering VS001A-spec fittings for VIGOUR Ultra-High Purity Products, add "P" to the order number. Example: VVR-MC4-F4-P

Face Seal Fitting VVR Series

Male Union^①

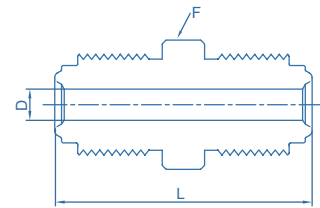

VFS Size in.	Material	Ordering Number	Dimensions, in.(mm)			Working Pressure psig (bar)	
			L	D	F	NI	SS
1/8	316L	VVR-MU2 ^②	1.13 (28.7)	0.09 (2.3)	3/8	9000 (620)	11200 (771)
1/4		VVR-MU4	1.55 (39.4)	0.18 (4.6)	5/8	8000 (551)	10000 (689)
1/2		VVR-MU8	1.84 (46.7)	0.40 (10.2)	15/16	3500 (241)	4300 (296)
3/4		VVR-MU12	2.44 (62.0)	0.62 (15.7)	1-5/16	3000 (206)	3700 (254)
1		VVR-MU16	2.59 (65.8)	0.87 (22.1)	1-5/8	2400 (165)	3000 (206)

① VFS components with fixed threads must remain stationary during installation.

These fitting connections should be assembled only to glands with rotating male or female threaded nuts.

② Not designed for gasket retainer assembly

* To order fittings manufactured for Surface finish Ra(Average)<0.4 add BA to the ordering number. Example: VVR-MU4-BA

* Default process spec: VS001B. If ordering VS001A-spec fittings for VIGOUR Ultra-High Purity Products, add "P" to the order number. Example: VVR-MU4-P

Male Union Tee

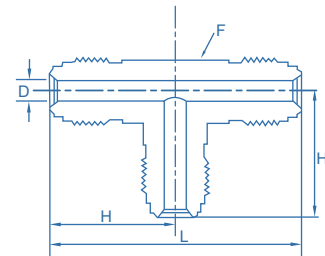

VFS Size in.	Material	Ordering Number	Dimensions, in.(mm)				Working Pressure psig (bar)	
			L	D	F	H	NI	SS
1/8	316L	VVR-MUT-2	1.78 (45.2)	0.09 (2.3)	7/16	0.89 (22.6)	9000 (620)	11200 (771)
1/4		VVR-MUT-4	2.14 (54.4)	0.18 (4.6)	1/2	1.07 (27.2)	8000 (551)	10000 (689)
1/2		VVR-MUT-8	2.90 (73.7)	0.40 (10.2)	13/16	1.45 (36.8)	3500 (241)	4300 (296)
3/4		VVR-MUT-12	3.84 (97.5)	0.62 (15.7)	1-1/4	1.92 (48.8)	3000 (206)	3700 (254)
1		VVR-MUT-16	4.00 (102)	0.87 (22.1)	1-11/16	2.00 (50.8)	2400 (165)	3000 (206)

* To order fittings manufactured for Surface finish Ra(Average)<0.4 add BA to the ordering number. Example: VVR-MUT-4-BA

* Default process spec: VS001B. If ordering VS001A-spec fittings for VIGOUR Ultra-High Purity Products, add "P" to the order number. Example: VVR-MUT-4-P

Flow Restrictors

- This product can be used in liquid or gas delivery systems where repeatable flow reduction or limiting is required.
- one piece, compact design saves space
- standard orifice sizes drilled through a 1/4 in. male VFS union
- no dead volume for clean operation

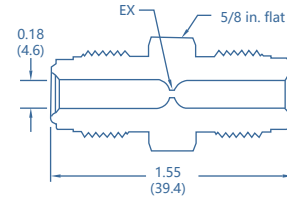

Tube Size in.	Ordering Number	Dimensions, in.(mm) EX	Working Pressure psig (bar)
1/4	VVR-MU4-DM-010	0.010 (0.254)	10000 (689)
	VVR-MU4-DM-012	0.012 (0.305)	
	VVR-MU4-DM-015	0.015 (0.381)	
	VVR-MU4-DM-017	0.017 (0.432)	
	VVR-MU4-DM-020	0.020 (0.508)	
	VVR-MU4-DM-023	0.023 (0.584)	
	VVR-MU4-DM-025	0.025 (0.635)	
	VVR-MU4-DM-026	0.026 (0.660)	
	VVR-MU4-DM-027	0.027 (0.686)	
	VVR-MU4-DM-030	0.030 (0.762)	
VVR-MU4-DM-035	0.035 (0.889)		
VVR-MU4-DM-040	0.040 (1.016)		

Tube Size in.	Ordering Number	Dimensions, in.(mm) EX	Working Pressure psig (bar)
1/4	VVR-MU4-DM-045	0.045 (1.143)	10000 (689)
	VVR-MU4-DM-050	0.050 (1.270)	
	VVR-MU4-DM-055	0.055 (1.397)	
	VVR-MU4-DM-060	0.060 (1.529)	
	VVR-MU4-DM-070	0.070 (1.778)	
	VVR-MU4-DM-075	0.075 (1.905)	
	VVR-MU4-DM-080	0.080 (2.032)	
	VVR-MU4-DM-085	0.085 (2.159)	
	VVR-MU4-DM-090	0.090 (2.286)	
	VVR-MU4-DM-093	0.093 (2.362)	
VVR-MU4-DM-095	0.095 (2.413)		
VVR-MU4-DM-100	0.100 (2.540)		

* Default process spec: VS001B. If ordering VS001A-spec fittings for VIGOUR Ultra-High Purity Products, add "P" to the order number. Example: VVR-MU4-DM-010-P

* The VFS component with fixed threads must be secured during the installation process and can only be connected to internally threaded pipes with rotating nuts.

* For custom metric-sized flow restrictor fittings, please contact the manufacturer.

Fitting Lock Device

This device is intended for use on VIGOUR VFS metal gasket face seal assemblies with standard male and female nuts.



Size in.	Material	Ordering Number
1/4	316L	VVR-FLD-4
1/2	316L	VVR-FLD-8



Size in.	Material	Matching product	Ordering Number
1/4	316L	VDV32	VVR-FLD-DV32-4
		VDV33	VVR-FLD-DV33-4
1/2	316L	VDV32	VVR-FLD-DV32-8

* Default process spec: VS001B.

Face Seal Fitting HVVR Series

High-Flow Connections

Glands Tube Butt Weld

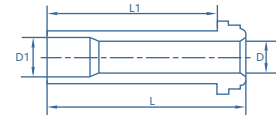

Tube Size in.	Wall Thickness in.	VFS Size in.	Material	Ordering Number	Dimensions, in.(mm)				Working Pressure psig (bar)	
					L	L1	D	D1	Ni	316L
3/8	0.035	1/4	316L	HVVR-HG4-TB6-L15	0.60 (15.2)	0.41 (10.4)	0.25 (6.4)	0.31 (7.9)	3300 (227)	3300 (227)
3/8	0.035	1/4	316L	HVVR-HG4-TB6-L30	1.19 (30.2)	1.00 (25.4)	0.25 (6.4)	0.31 (7.9)	3300 (227)	3300 (227)
3/8	0.035	1/4	316L	HVVR-HG4-TB6-L33	1.31 (33.3)	1.12 (28.4)	0.25 (6.4)	0.31 (7.9)	3300 (227)	3300 (227)

* Default process spec: VS001B. If ordering VS001A-spec fittings for VIGOUR Ultra-High Purity Products, add "P" to the order number. Example: HVVR-HG4-TB6-L15-P

Bodies Tube Butt Weld

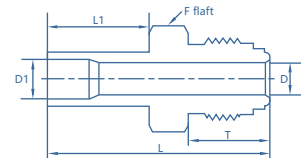

Tube Size in.	VFS Size in.	Material	Ordering Number	Dimensions, in.(mm)						Working Pressure psig (bar)	
				L	L1	T	D	D1	F	Ni	316L
3/8	1/4	316L	HVVR-MG4-TB6	1.68 (42.7)	0.75 (19.1)	0.62 (15.7)	0.25 (6.4)	0.31 (7.9)	5/8	3300 (227)	3300 (227)

* Default process spec: VS001B. If ordering VS001A-spec fittings for VIGOUR Ultra-High Purity Products, add "P" to the order number. Example: HVVR-MG4-TB6-P

Bodies Automatic Tube Weld

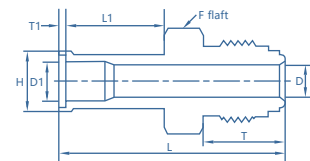

Tube Size in.	VFS Size in.	Material	Ordering Number	Dimensions, in.(mm)								Working Pressure psig (bar)	
				L	L1	T	T1	D	D1	F	H	Ni	316L
3/8	1/4	316L	HVVR-AHG4-TW6	1.71 (43.4)	0.75 (19.1)	0.62 (15.7)	0.03 (0.8)	0.25 (6.4)	0.31 (7.9)	5/8	0.41 (10.4)	3300 (227)	3300 (227)

* Default process spec: VS001B. If ordering VS001A-spec fittings for VIGOUR Ultra-High Purity Products, add "P" to the order number. Example: HVVR-AHG4-TW6-P

High-Flow Connections

Bodies Bulkhead Connector

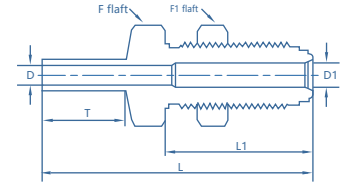

Tube Size in.	VFS Size in.	Material	Ordering Number	Dimensions, in.(mm)							Panel Hole Dia	Max Panel Thickness	Working Pressure psig (bar)	
				L	L1	T	D	D1	F	F1			Ni	316L
3/8	1/4	316L	HVVR-BMG4-TB6	2.36 (59.9)	1.30 (33.0)	0.75 (19.1)	0.31 (7.9)	0.25 (6.4)	3/4	3/4	19/32 (15.0)	0.44 (11.2)	3300 (227)	3300 (227)

* Default process spec: VS001B. If ordering VS001A-spec fittings for VIGOUR Ultra-High Purity Products, add "P" to the order number. Example: HVVR-BMG4-TB6-P

Union Elbow

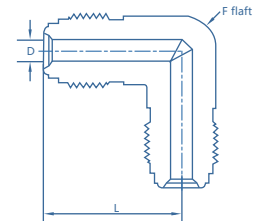

VFS Size in.	Material	Ordering Number	Dimensions, in.(mm)			Working Pressure psig (bar)	
			L	D	F	Ni	316L
1/4	316L	HVVR-UE4	1.07 (27.2)	0.25 (6.4)	1/2	8000 (551)	10000 (689)

* Default process spec: VS001B. If ordering VS001A-spec fittings for VIGOUR Ultra-High Purity Products, add "P" to the order number. Example: HVVR-UE4-P

Union Tee

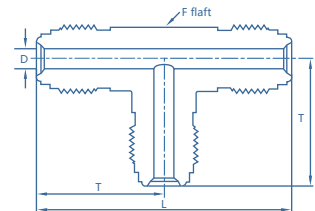

VFS Size in.	Material	Ordering Number	Dimensions, in.(mm)				Working Pressure psig (bar)	
			L	T	D	F	Ni	316L
1/4	316L	HVVR-UT4	2.14 (54.4)	1.07 (27.2)	0.25 (6.4)	1/2	8000 (551)	10000 (689)

* Default process spec: VS001B. If ordering VS001A-spec fittings for VIGOUR Ultra-High Purity Products, add "P" to the order number. Example: HVVR-UT4-P

Face Seal Fitting HVVR Series

High-Flow Connections

Nuts Female

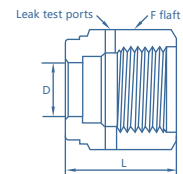

VFS Size in.	Material	Ordering Number	Dimensions, in.(mm)		
			L	D	F
1/4	316L	HVVR-FN4 ^①	0.81 (20.6)	0.39 (9.9)	3/4

^① Use for High Flow Connections: Glands Tube Butt Weld
* Default process spec: VS001B.

Nuts Male

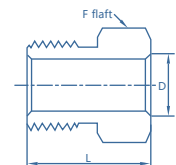

VFS Size in.	Material	Ordering Number	Dimensions, in.(mm)		
			L	D	F
1/4	316L	HVVR-MN4	0.71 (18.0)	0.39 (9.9)	5/8

* Default process spec: VS001B.

Union Elbow

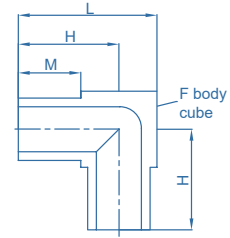

Tube OD in.	Wall Thickness in.	Ordering Number	Dimensions, in.(mm)				Working Pressure psig (bar)
			L	M	F	H	
1/8	0.028	VMW-UE2 VMW-UE2-SLV	0.56 (14.2)	0.25 (6.4)	5/16	0.41 (10.4)	8500 (585)
1/4	0.035	VMW-UE4 VMW-UE4-SLV	0.56 (14.2)		5/16	0.41 (10.4)	5100 (351)
3/8	0.035	VMW-UE6 VMW-UE6-SLV	0.69 (17.5)		7/16	0.47 (11.9)	3300 (227)
1/2	0.049	VMW-UE8 VMW-UE8-SLV	0.81 (20.6)		9/16	0.53 (13.5)	3700 (254)
3/4	0.065	VMW-UE12 VMW-UE12-SLV	1.06 (27.0)		13/16	0.66 (16.6)	2400 (165)

* To order fittings manufactured for Surface Finish Ra(Average)<0.4 add BA to the ordering number. Example: VMW-UE6-BA

* Default process spec: VS001B. If ordering VS001A-spec fittings for VIGOUR Ultra-High Purity Products, add "P" to the order number. Example: VMW-UE4-P

Reducing Elbow

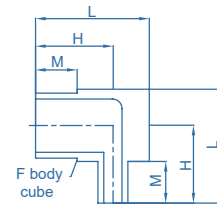

Tube OD in.	Wall Thickness in.	Tube OD in.	Wall Thickness in.	Ordering Number	Dimensions, in.(mm)				Working Pressure psig (bar)
					L	M	F	H	
1/4	0.035	1/8	0.028	VMW-RE4-2 VMW-RE4-2-SLV	0.56 (14.2)	0.25 (6.4)	5/16	0.41 (10.3)	3300 (227)
3/8	0.035	1/4	0.035	VMW-RE6-4 VMW-RE6-4-SLV	0.69 (17.5)		7/16	0.47 (11.9)	3300 (227)
1/2	0.049	1/4	0.035	VMW-RE8-4 VMW-RE8-4-SLV	0.81 (20.6)		9/16	0.53 (13.5)	3700 (254)
1/2	0.049	3/8	0.035	VMW-RE8-6 VMW-RE8-6-SLV	0.81 (20.6)		9/16	0.53 (13.5)	3300 (227)
3/4	0.065	1/4	0.035	VMW-RE12-4 VMW-RE12-4-SLV	1.05 (26.9)		13/16	0.65 (16.6)	2400 (165)
3/4	0.065	3/8	0.035	VMW-RE12-6 VMW-RE12-6-SLV	1.05 (26.9)	13/16	0.65 (16.6)	2400 (165)	
3/4	0.065	1/2	0.049	VMW-RE12-8 VMW-RE12-8-SLV	1.05 (26.9)	13/16	0.65 (16.6)	2400 (165)	

* To order fittings manufactured for Surface Finish Ra(Average)<0.4 add BA to the ordering number. Example: VMW-RE6-4-BA

* Default process spec: VS001B. If ordering VS001A-spec fittings for VIGOUR Ultra-High Purity Products, add "P" to the order number. Example: VMW-RE4-2-P

Micro Weld Fitting VMW Series

Union Tee

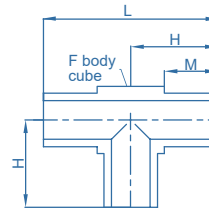

Tube OD in.	Wall Thickness in.	Ordering Number	Dimensions, in.(mm)				Working Pressure psig (bar)
			L	M	F	H	
1/8	0.028	VMW-UT2 VMW-UT2-SLV	0.82 (20.8)	0.25 (6.4)	5/16	0.41 (10.4)	8500 (585)
1/4	0.035	VMW-UT4 VMW-UT4-SLV	0.82 (20.8)		5/16	0.41 (10.4)	5100 (351)
3/8	0.035	VMW-UT6 VMW-UT6-SLV	0.94 (23.9)		7/16	0.47 (11.9)	3300 (227)
1/2	0.049	VMW-UT8 VMW-UT8-SLV	1.06 (26.9)		9/16	0.53 (13.5)	3700 (254)
3/4	0.065	VMW-UT12 VMW-UT12-SLV	1.31 (33.3)		13/16	0.65 (16.6)	2400 (165)

* Default process spec: VS001B. If ordering VS001A-spec fittings for VIGOUR Ultra-High Purity Products, add "P" to the order number. Example: VMW-UT4-P

Reducing Tee

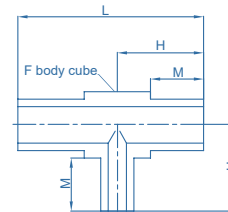

Tube OD in.	Wall Thickness in.	Tube OD in.	Wall Thickness in.	Ordering Number	Dimensions, in.(mm)				Working Pressure psig (bar)
					L	M	F	H	
1/4	0.035	1/8	0.028	VMW-RT4-2 VMW-RT4-2-SLV	0.81 (20.6)	0.25 (6.4)	5/16	0.41 (10.3)	3300 (227)
3/8	0.035	1/4	0.035	VMW-RT6-4 VMW-RT6-4-SLV	0.94 (23.9)		7/16	0.47 (11.9)	3300 (227)
1/2	0.049	1/4	0.035	VMW-RT8-4 VMW-RT8-4-SLV	1.06 (26.9)		9/16	0.53 (13.5)	3700 (254)
1/2	0.049	3/8	0.035	VMW-RT8-6 VMW-RT8-6-SLV	1.06 (26.9)		9/16	0.53 (13.5)	3300 (227)
3/4	0.065	1/4	0.035	VMW-RT12-4 VMW-RT12-4-SLV	1.31 (33.3)		13/16	0.65 (16.6)	2400 (165)
3/4	0.065	3/8	0.035	VMW-RT12-6 VMW-RT12-6-SLV	1.31 (33.3)	13/16	0.65 (16.6)	2400 (165)	
3/4	0.065	1/2	0.049	VMW-RT12-8 VMW-RT12-8-SLV	1.31 (33.3)	13/16	0.65 (16.6)	2400 (165)	

* To order fittings manufactured for Surface Finish Ra(Average) < 0.4 add BA to the ordering number. Example: VMW-RT6-4-BA

* Default process spec: VS001B. If ordering VS001A-spec fittings for VIGOUR Ultra-High Purity Products, add "P" to the order number. Example: VMW-RT4-2-P

Tribow

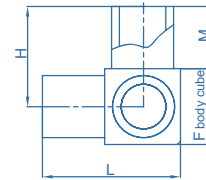

Tube OD in.	Wall Thickness in.	Ordering Number	Dimensions, in.(mm)				Working Pressure psig (bar)
			L	M	F	H	
1/4	0.035	VMW-TB4 VMW-TB4-SLV	0.56 (14.2)	0.25 (6.4)	5/16	0.41 (10.4)	5100 (351)
3/8	0.035	VMW-TB6 VMW-TB6-SLV	0.69 (17.5)		7/16	0.47 (11.9)	3300 (227)
1/2	0.049	VMW-TB8 VMW-TB8-SLV	0.81 (20.6)		9/16	0.53 (13.5)	3700 (254)
3/4	0.065	VMW-TB12 VMW-TB12-SLV	1.06 (26.9)		13/16	0.65 (16.6)	2400 (165)

* To order fittings manufactured for Surface Finish Ra(Average)<0.4 add BA to the ordering number. Example: VMW-TB6-BA

* Default process spec: VS001B. If ordering VS001A-spec fittings for VIGOUR Ultra-High Purity Products, add "P" to the order number. Example: VMW-TB4-P

Cross Union

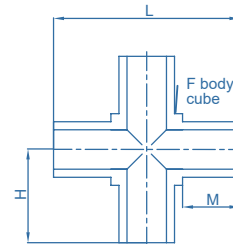

Tube OD in.	Wall Thickness in.	Ordering Number	Dimensions, in.(mm)				Working Pressure psig (bar)
			L	M	F	H	
1/8	0.028	VMW-CU2 VMW-CU2-SLV	0.82 (20.8)	0.25 (6.4)	5/16	0.41 (10.4)	8500 (585)
1/4	0.035	VMW-CU4 VMW-CU4-SLV	0.82 (20.8)		5/16	0.41 (10.4)	5100 (351)
3/8	0.035	VMW-CU6 VMW-CU6-SLV	0.94 (23.9)		7/16	0.47 (11.9)	3300 (227)
1/2	0.049	VMW-CU8 VMW-CU8-SLV	1.06 (26.9)		9/16	0.53 (13.5)	3700 (254)

* To order fittings manufactured for Surface Finish Ra(Average)<0.4 add BA to the ordering number. Example: VMW-CU4-BA

* Default process spec: VS001B. If ordering VS001A-spec fittings for VIGOUR Ultra-High Purity Products, add "P" to the order number. Example: VMW-CU4-P

Micro Weld Fitting VMW Series

Reducing Union

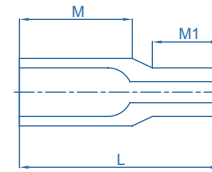

Tube OD in.	Wall Thickness in.	Tube OD in.	Wall Thickness in.	Ordering Number	Dimensions, in.(mm)			Working Pressure psig (bar)
					L	M	M1	
1/4	0.035	1/8	0.028	VMW-RU4-2 VMW-RU4-2-SLV				5100 (351)
3/8	0.035	1/4	0.035	VMW-RU6-4 VMW-RU6-4-SLV				3300 (227)
1/2	0.049	1/4	0.035	VMW-RU8-4 VMW-RU8-4-SLV	0.75 (19.0)	0.42 (10.7)	0.25 (6.4)	3700 (254)
1/2	0.049	3/8	0.035	VMW-RU8-6 VMW-RU8-6-SLV				3300 (227)
3/4	0.065	1/4	0.035	VMW-RU12-4 VMW-RU12-4-SLV				2400 (165)
3/4	0.065	3/8	0.035	VMW-RU12-6 VMW-RU12-6-SLV				2400 (165)
3/4	0.065	1/2	0.049	VMW-RU12-8 VMW-RU12-8-SLV				2400 (165)

* To order fittings manufactured for Surface Finish Ra(Average)<0.4 add BA to the ordering number. Example: VMW-RU6-4-BA

* Default process spec: VS001B. If ordering VS001A-spec fittings for VIGOUR Ultra-High Purity Products, add "P" to the order number. Example: VMW-RU4-2-P

45° Union Elbow

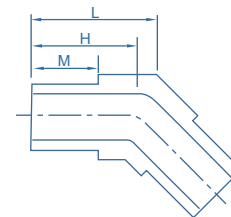

Tube OD in.	Wall Thickness in.	Ordering Number	Dimensions, in.(mm)				Working Pressure psig (bar)
			L	M	F	H	
1/4	0.035	VMW-VE4-R45 VMW-VE4-R45-SLV	0.47 (11.9)		5/16	0.41 (10.4)	5100 (351)
3/8	0.035	VMW-VE6-R45 VMW-VE6-R45-SLV	0.56 (14.2)	0.25 (6.4)	7/16	0.47 (11.9)	3300 (227)
1/2	0.049	VMW-VE8-R45 VMW-VE8-R45-SLV	0.64 (16.3)		9/16	0.53 (13.5)	3700 (254)
3/4	0.065	VMW-VE12-R45 VMW-VE12-R45-SLV	0.82 (20.9)		13/16	0.65 (16.6)	2400 (165)

* Default process spec: VS001B. If ordering VS001A-spec fittings for VIGOUR Ultra-High Purity Products, add "P" to the order number. Example: VMW-UE4-R45-P

Long Elbow 90°

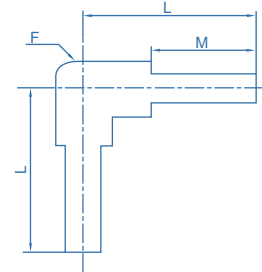

Tube OD in.	Wall Thickness in.	Ordering Number	Dimensions, in.(mm)			Working Pressure psig (bar)
			L	M	F	
1/4	0.035	VTW-LE4	1.23 (31.2)		7/16	5100 (351)
3/8	0.035	VTW-LE6	1.20 (30.5)		7/16	3300 (227)
1/2	0.049	VTW-LE8	1.34 (34.0)	0.75 (19.0)	11/16	3700 (254)
3/4	0.065	VTW-LE12	1.46 (37.1)		15/16	2400 (165)
1	0.065	VTW-LE16	1.34 (34.0)		1-1/4	1900 (130)

* To order fittings manufactured for Surface Finish Ra(Average)<0.4 add BA to the ordering number. Example: VTW-LE4-BA

* Default process spec: VS001B. If ordering VS001A-spec fittings for VIGOUR Ultra-High Purity Products, add "P" to the order number. Example: VTW-LE4-P

Reducing Long Elbow

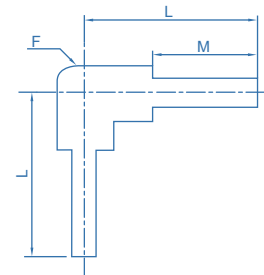

Tube OD in.	Wall Thickness in.	Tube OD in.	Wall Thickness in.	Ordering Number	Dimensions, in.(mm)			Working Pressure psig (bar)
					L	M	F	
3/8	0.035	1/4	0.035	VTW-RLE6-4	0.98 (25)		6/16	3300 (227)
1/2	0.049	1/4	0.035	VTW-RLE8-4	1.06 (27)		7/16	3700 (254)
1/2	0.049	3/8	0.035	VTW-RLE8-6	1.06 (27)		7/16	3300 (227)
3/4	0.065	1/4	0.035	VTW-RLE12-4	1.24 (31.5)	0.75 (19.0)	15/16	2400 (165)
3/4	0.065	3/8	0.035	VTW-RLE12-6	1.24 (31.5)		15/16	2400 (165)
3/4	0.065	1/2	0.049	VTW-RLE12-8	1.24 (31.5)		15/16	2400 (165)

* To order fittings manufactured for Surface Finish Ra(Average)<0.4 add BA to the ordering number. Example: VTW-RLE6-4-BA

* Default process spec: VS001B. If ordering VS001A-spec fittings for VIGOUR Ultra-High Purity Products, add "P" to the order number. Example: VTW-RLE6-4-P

Tube Butt Weld Fitting

VTW Series

Long Tee

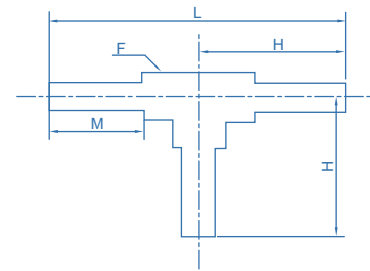

Tube OD in.	Wall Thickness in.	Ordering Number	Dimensions, in.(mm)				Working Pressure psig (bar)
			L	M	F	H	
1/4	0.035	VTW-LT4	2.46 (62.5)		7/16	1.23 (31.2)	5100 (351)
3/8	0.035	VTW-LT6	2.40 (61.0)		7/16	1.20 (30.5)	3300 (227)
1/2	0.049	VTW-LT8	2.68 (68.1)	0.75 (19.0)	11/16	1.34 (34.0)	3700 (254)
3/4	0.065	VTW-LT12	2.91 (73.9)		15/16	1.46 (37.1)	2400 (165)
1	0.065	VTW-LT16	2.68 (68.1)		1-1/4	1.34 (34.0)	1900 (130)

* To order fittings manufactured for Surface Finish Ra(Average) < 0.4 add BA to the ordering number. Example: VTW-LT4-BA

* Default process spec: VS001B. If ordering VS001A-spec fittings for VIGOUR Ultra-High Purity Products, add "P" to the order number. Example: VTW-LT4-P

Reducing Long Tee

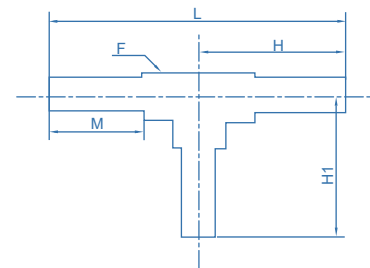

Tube OD in.	Wall Thickness in.	Tube OD in.	Wall Thickness in.	Ordering Number	Dimensions, in.(mm)					Working Pressure psig (bar)
					L	M	F	H	H1	
3/8	0.035	1/4	0.035	VTW-RLT6-4	2.39 (60.7)		7/16	1.20 (30.5)	1.23 (31.2)	3300 (227)
1/2	0.049	1/4	0.035	VTW-RLT8-4	2.67 (67.8)		11/16	1.34 (34.0)	1.34 (34.0)	3700 (254)
1/2	0.049	3/8	0.035	VTW-RLT8-6	2.67 (67.8)		11/16	1.34 (34.0)	1.35 (34.3)	3300 (227)
3/4	0.065	1/4	0.035	VTW-RLT12-4	2.91 (73.9)	0.75 (19.0)	15/16	1.46 (37.1)	1.48 (37.6)	2400 (165)
3/4	0.065	3/8	0.035	VTW-RLT12-6	2.91 (73.9)		15/16	1.46 (37.1)	1.48 (37.6)	2400 (165)
3/4	0.065	1/2	0.049	VTW-RLT12-8	2.48 (63.0)		15/16	1.24 (31.5)	1.24 (31.5)	2400 (165)

* To order fittings manufactured for Surface Finish Ra(Average) < 0.4 add BA to the ordering number. Example: VTW-RLT6-4-BA

* Default process spec: VS001B. If ordering VS001A-spec fittings for VIGOUR Ultra-High Purity Products, add "P" to the order number. Example: VTW-RLT6-4-P

Reducing Long Union

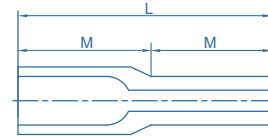

Tube OD in.	Wall Thickness in.	Tube OD in.	Wall Thickness in.	Ordering Number	Dimensions, in.(mm)		Working Pressure psig (bar)
					L	M	
3/8	0.035	1/4	0.035	VTW-RLU6-4			3300 (227)
1/2	0.049	1/4	0.035	VTW-RLU8-4			3700 (254)
1/2	0.049	3/8	0.035	VTW-RLU8-6			3300 (227)
3/4	0.065	1/4	0.035	VTW-RLU12-4			2400 (165)
3/4	0.065	3/8	0.035	VTW-RLU12-6	1.50 (38.1)	0.75 (19.0)	2400 (165)
3/4	0.065	1/2	0.049	VTW-RLU12-8			2400 (165)
1	0.065	1/4	0.035	VTW-RLU16-4			2400 (165)
1	0.065	3/8	0.049	VTW-RLU16-6			2400 (165)
1	0.065	1/2	0.049	VTW-RLU16-8			2400 (165)
1	0.065	3/4	0.049	VTW-RLU16-12			2400 (165)

* To order fittings manufactured for Surface Finish Ra(Average) < 0.4 add BA to the ordering number. Example: VTW-RLU6-4-BA

* Default process spec: VS001B. If ordering VS001A-spec fittings for VIGOUR Ultra-High Purity Products, add "P" to the order number. Example: VTW-RLU6-4-P

Weld Assemblies

VWR Series

Welded Assemblies

Female Elbow

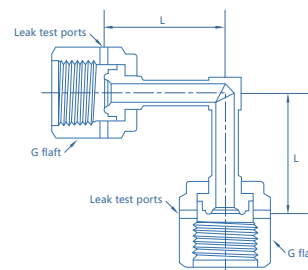

VFS Size in.	Material	Ordering Number	Dimensions, in.(mm)		Working Pressure psig (bar)	
			L	G	Ni	316L
1/4	316L	VWR-FE4	1.00 (25.4)	3/4	8000 (551)	10000 (689)

* Default process spec: VS001B. If ordering VS001A-spec fittings for VIGOUR Ultra-High Purity Products, add "P" to the order number. Example: VWR-FE4-P

Female Tee

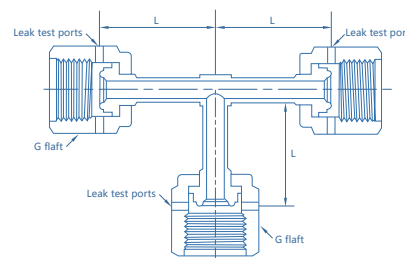

VFS Size in.	Material	Ordering Number	Dimensions, in.(mm)		Working Pressure psig (bar)	
			L	G	Ni	316L
1/4	316L	VWR-FT4	1.00 (25.4)	3/4	8000 (551)	10000 (689)

* Default process spec: VS001B. If ordering VS001A-spec fittings for VIGOUR Ultra-High Purity Products, add "P" to the order number. Example: VWR-FT4-P

Product Feature

- Cylinder Connections
- Connect to a cylinder valve
- The product is fabricated in compliance with the VS001B process specification
- 1/4" NPT male / 6mm tube fitting / 6mm OD tube connection
- All connections are degrease to oxygen service
- 15µin. Ra max., 10µin. Ra average surface finish
- Products tested & packaged in Class 100 cleanroom

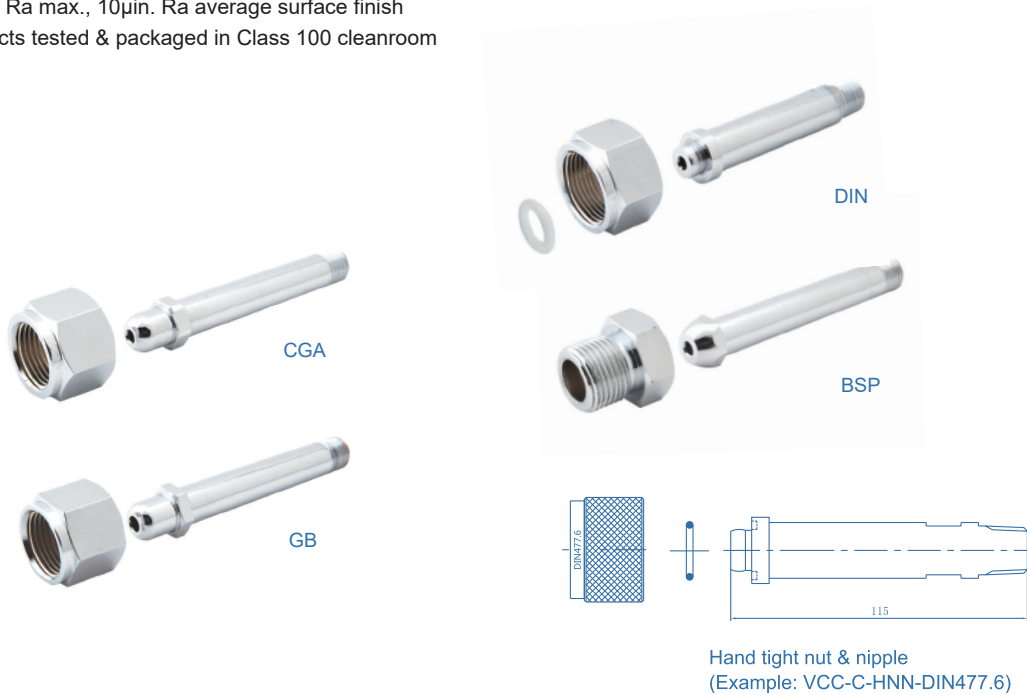

Ordering Information

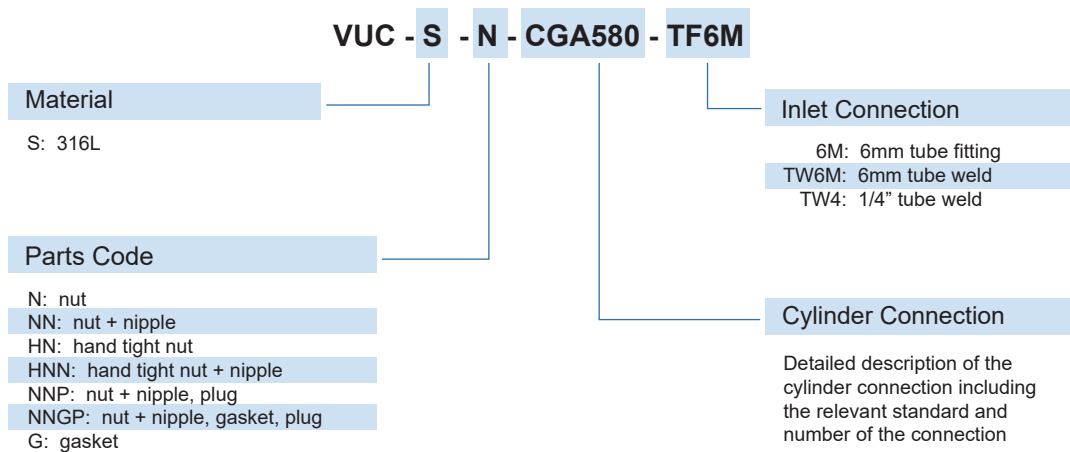

Cylinder Connection VUC DISS Series

Technical Data

Materials of Construction	
Wetted	
Nuts	316 Stainless Steel
Nipples	316L Stainless Steel
Outlet Adapters	316L Stainless Steel
Cylinder Valve Outlet Caps	316L Stainless Steel
Gaskets	Nickel Standard*

- * Contact factory for other materials available.
- * The product is fabricated in compliance with the VS001B process specification.
- * Products tested & packaged in Class 100 cleanroom



Nut, Nipple and Nickel Gasket Assembly

CGA/DISS Number	End Connection	F Hex Flat in.
632 ~ 642	1/4" Tube Weld	1-1/4
	1/2" Tube Weld	
	1/4" VFS Male	
712 ~ 728	1/4" Tube Weld	1-3/8"
	1/2" Tube Weld	
	1/4" VFS Male	

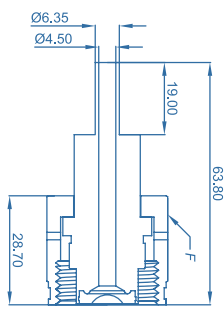

1/4" Tube Weld

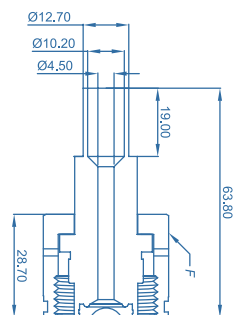

1/2" Tube Weld

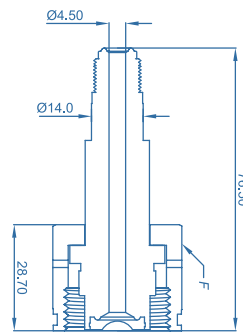

1/4" VFS Male

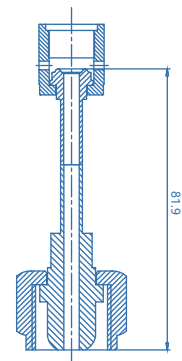

Cylinder Connections to
1/4" VFS Female

CAPS

CGA/DISS Number	Ordering Number	Material	F Hex Flat in.	H Length in.	Gas Tight
632 ~ 642	VUC-DISS-C-63	Nickel / PTFE	1-1/4	0.98	Yes
712 ~ 728	VUC-DISS-C-71		1-3/8		

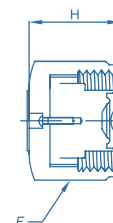

Cylinder Connection VUC DISS Series

GASKETS

Material	Ordering Number	A	H	E
Nickle	VUC-DISS-G-NI	0.56	0.105	0.21
PCTFE	VUC-DISS-G-PC		0.125	

* Hardness Max. 105 Vickers.

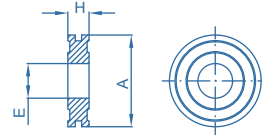

Plugs and Adapters

CGA/DISS Number	Ordering Number	End Connection	H Overall Length	F Hex Flat in.
632 ~ 642	VUC-DISS-BP-63	Plug	1.53	1-1/8
712 ~ 718	VUC-DISS-BP-71	Plug	1.53	1-1/4
720 ~ 728	VUC-DISS-BP-72	Plug	1.53	1-1/4

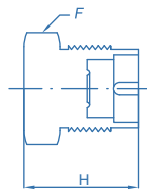

Plug

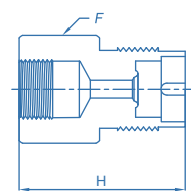

Adaptor

Ordering Information

VUC-DISS- NNG - CGA632 - TW4 - Ni

Parts Code

N: nut
P: plug
NNG: nut + nipple, gasket
NNGP: nut + nipple, gasket, plug

CGA Number

CGA632 CGA642 CGA720
CGA634 CGA712 CGA722
CGA636 CGA714 CGA724
CGA638 CGA716 CGA726
CGA640 CGA718 CGA728

Gasket Material

Ni: Nickle
PC: PCTFE

End Connection

MV4: 1/4" VFS male
TW4: 1/4" tube weld
TW8: 1/2" tube weld
FV4: 1/4" VFS Female

* Other connection standard, consult factory

Pressure Gauge

VGU/VRU/VGT/VRT Series

Product Feature

- UHP "clean" for semiconductor gas applications, in accordance with SEMI/SEMATECH
- Purged with nitrogen
- Protective cap over threaded connection
- The product is fabricated in compliance with the VS001B process specification
- 100% factory calibrated and helium leak tested to a maximum rate of 1×10^{-9} mbar l/s He
- Products tested & packaged in Class 100 cleanroom

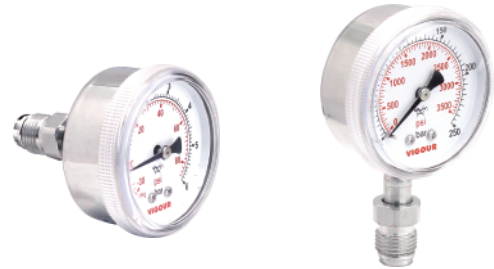

VRU

VGU

Technical Data

Type	pressure gauge
Materials:	
End connection	316L VAR, electropolished
Bourdon tube	316L SS
Case	304 SS
Lens	polycarbonate
Movement	stainless steel
Dial & Pointer	aluminum
Scale	psig/bar dual scale
Dial size	2"
Accuracy	Grade A per ASME B40.1
Ambient temperature	-40°F to 140°F (-40°C to 60°C)



VRT

VGT

Dimensions

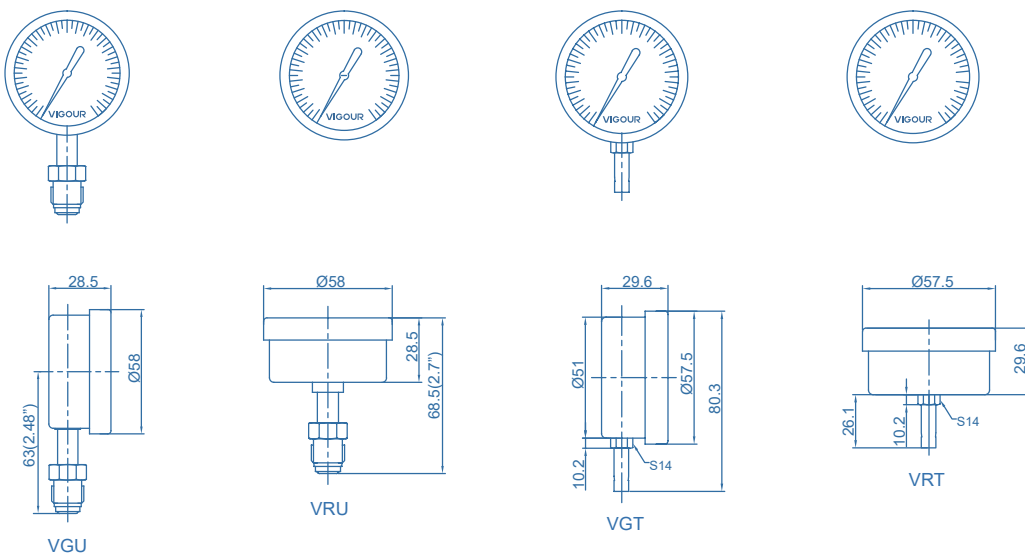

Ordering Information

VGU/VRU Series (Ultra High Purity)

Ordering Number	Inlet Connection	Pressure Range (bar/psig)
VGU Series, Lower Mount, VFS End		
VGU20S-1.6/2.5/4/6/7/10/14/16/25/35/60B-FV4	1/4" VFS female	0~1.6/2.5/4/6/7/10/14/16/25/35/60 bar 0~23/30/60/86/100/140/200/230/350/500/860 psig
VGU20S-1.6/2.5/4/6/7/10/14/16/25/35/60B-MV4	1/4" VFS male	
VGU20S-1.6/2.5/4/6/7/10/14/16/25/35/60B-RMV4	1/4" rotatable VFS male	
VGU20S-100/150/250/315/400B-FV4	1/4" VFS female	0~100/150/250/315/400 bar 0~1500/2000/3500/4500/5800 psig
VGU20S-100/150/250/315/400B-MV4	1/4" VFS male	
VGU20S-100/150/250/315/400B-RMV4	1/4" rotatable VFS male	
VGU20S-V1.6/V2.5/V4/V6/V7/V10/V14/V16B-FV4	1/4" VFS female	Vac~1.6/2.5/4/6/7/10/14/16 bar Vac~23/30/60/86/100/140/200/230 psig
VGU20S-V1.6/V2.5/V4/V6/V7/V10/V14/V16B-MV4	1/4" VFS male	
VGU20S-V1.6/V2.5/V4/V6/V7/V10/V14/V16B-RMV4	1/4" rotatable VFS male	

VRU Series, Center-Back Mount, VFS End		
VRU20S-1.6/2.5/4/6/7/10/14/16/25/35/60B-FV4	1/4" VFS female	0~1.6/2.5/4/6/7/10/14/16/25/35/60 bar 0~23/30/60/86/100/140/200/230/350/500/860 psig
VRU20S-1.6/2.5/4/6/7/10/14/16/25/35/60B-MV4	1/4" VFS male	
VRU20S-1.6/2.5/4/6/7/10/14/16/25/35/60B-RMV4	1/4" rotatable VFS male	
VRU20S-100/150/250/315/400B-FV4	1/4" VFS female	0~100/150/250/315/400 bar 0~1500/2000/3500/4500/5800 psig
VRU20S-100/150/250/315/400B-MV4	1/4" VFS male	
VRU20S-100/150/250/315/400B-RMV4	1/4" rotatable VFS male	
VRU20S-V1.6/V2.5/V4/V6/V7/V10/V14/V16B-FV4	1/4" VFS female	Vac~1.6/2.5/4/6/7/10/14/16 bar Vac~23/30/60/86/100/140/200/230 psig
VRU20S-V1.6/V2.5/V4/V6/V7/V10/V14/V16B-MV4	1/4" VFS male	
VRU20S-V1.6/V2.5/V4/V6/V7/V10/V14/V16B-RMV4	1/4" rotatable VFS male	

VGT/VRT Series(Tube Connection)

Ordering Number	Inlet Connection	Pressure Range (bar/psig)
VGT Series, Lower Mount, Tube End		
VGT20S-1.6/2.5/4/6/7/10/14/16/25/35/60B-T4	1/4"tube	0~1.6/2.5/4/6/7/10/14/16/25/35/60 bar 0~23/30/60/86/100/140/200/230/350/500/860 psig
VGT20S-1.6/2.5/4/6/7/10/14/16/25/35/60B-T6M	6mm tube	
VGT20S-100/150/250/315/400B-T4	1/4"tube	
VGT20S-100/150/250/315/400B-T6M	6mm tube	0~100/150/250/315/400 bar 0~1500/2000/3500/4500/5800 psig
VGT20S-V2.5/V4/V16B-T4	1/4"tube	
VGT20S-V2.5/V4/V16B-T6M	6mm tube	
VRT Series, Center-Back Mount, Tube End		
VRT20S-1.6/2.5/4/6/7/10/14/16/25/35/60B-T4	1/4"tube	0~1.6/2.5/4/6/7/10/14/16/25/35/60 bar 0~23/30/60/86/100/140/200/230/350/500/860 psig
VRT20S-1.6/2.5/4/6/7/10/14/16/25/35/60B-T6M	6mm tube	
VRT20S-100/150/250/315/400B-T4	1/4"tube	
VRT20S-100/150/250/315/400B-T6M	6mm tube	0~100/150/250/315/400 bar 0~1500/2000/3500/4500/5800 psig
VRT20S-V1.6/V2.5/V4/V6/V7/V10/V14/V16B-T4	1/4"tube	
VRT20S-V1.6/V2.5/V4/V6/V7/V10/V14/V16B-T6M	6mm tube	

Contact Gauge

VGU20SE / VRU20SE Series

Product Feature

- Contact gauge (KI) with inductance contact
- For monitoring gas supply pressure and shortage
- standard surface finish 10µin. (0.25µm) Ra
- For inert, combustible, oxidizing, and corrosive gases and gas mixtures
- The product is fabricated in compliance with the VS001B process specification
- Line 0.5m
- With NAMUR sensor
- Set point adjustable over 0~24% of scale
- Tested for use with oxygen
- Products tested & packaged in Class 100 cleanroom



VGU

Typical Applications

Gas panels may be optionally equipped with contact pressure gauges. Contact pressure gauges combine the advantages of in situ readings with the demands of electrical signal transmissions. In combination with signal boxes, this creates visual and acoustic warning signals in the case of pres-sure drop and the monitoring of line pressure according to adjustable thresholds.



VRU

Technical Data

Dual scale:	bar / psi
Connection:	1/4" VFS Male / 1/4" VFS Female
Size:	2"
Accuracy:	±2.5%
Body Material:	316L
Switching function:	NC
Outlet type:	NAMUR
Temperature:	-25~100°C

Dimensions (mm)

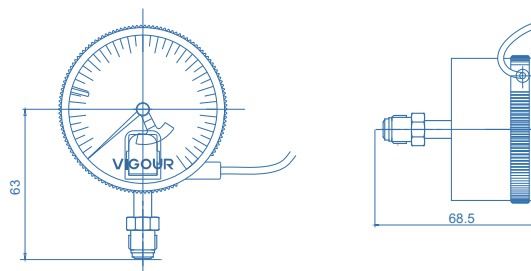

Ordering Information

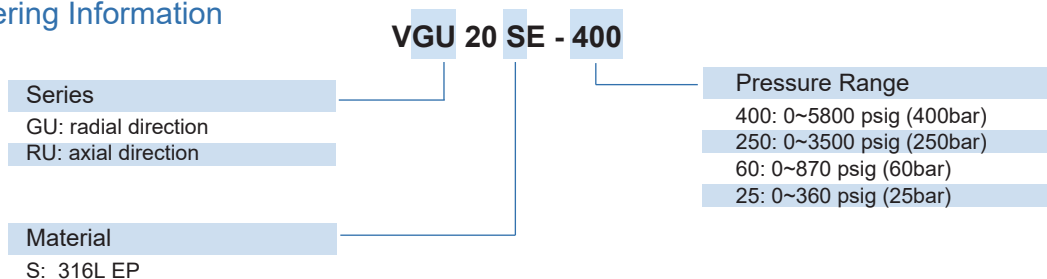

Contact Gauge VCG20S/VRG20S Series

Product Features

- Contact gauge (KI) with inductance contact
- For monitoring gas supply pressure and shortage
- For inert, combustible, oxidizing, and corrosive gases and gas mixtures
- The product is fabricated in compliance with the VS001B process specification
- standard surface finish 10µin. (0.25µm) Ra
- internals are electropolished to optionally meet purrty standards
- 100% helium-leak-tested
- Products tested & packaged in Class 100 cleanroom



Typical Applications

Gas panels may be optionally equipped with contact pressure gauges. Contact pressure gauges combine the advantages of in situ readings with the demands of electrical signal transmissions. In combination with signal boxes, this creates visual and acoustic warning signals in the case of pres-sure drop and the monitoring of line pressure according to adjustable thresholds.

Technical Data

Dual scale:	bar / psi
Connection:	VFS connection
Size:	2"
Accuracy:	Grade A per ASME B40.1
Body Material:	316L
Switching function:	NC / NO
Electrical rating	switching voltage ≤ AC 24V / DC 24V switching current ≤ 0.5A switching power ≤ 10VA / W

Dimensions (mm)

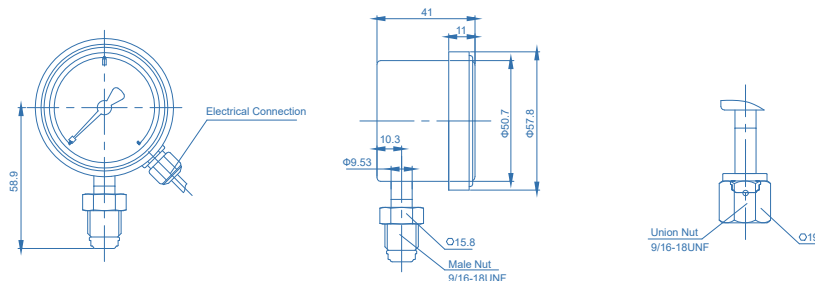

Ordering Information

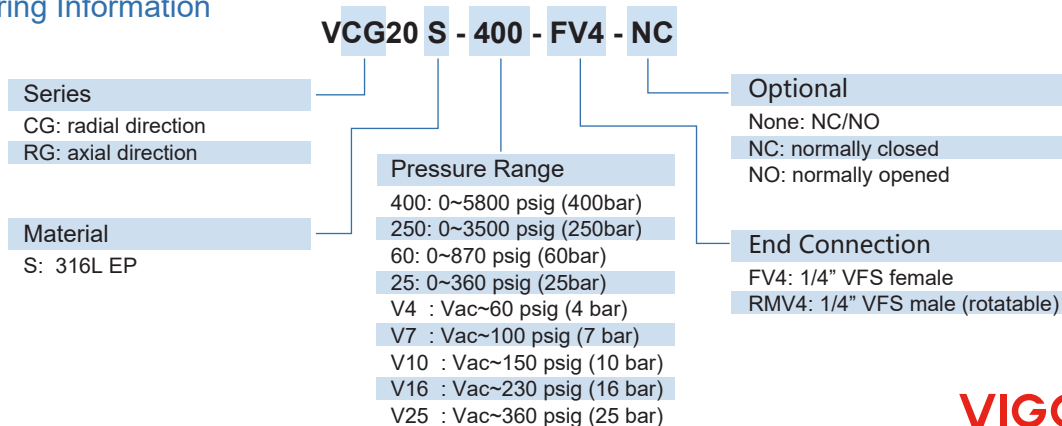

Scope

This document specifies guidelines used by VIGOUR Company for producing ultrahigh-purity (UHP) electropolished stainless steel products as well as ultrahigh-purity plastic products. This document must be used in conjunction with product catalogs, technical bulletins, and reports for complete product information.

Design

Products are designed with specific functional industry standards in mind. Where specific test results exist in the literature, the following standards are applicable:

Stainless Steel Products:

- Moisture analysis in accordance with ASTM F1397, "Standard Test Method for Determination of Moisture Contribution by Gas Distribution System Components"
- Hydrocarbon analysis in accordance with ASTM F1398, "Standard Test Method for Determination of Total Hydrocarbon Contribution by Gas Distribution System Components"
- Ionic cleanliness in accordance with ASTM F1374, "Standard Test Method for the Determination of Ionic/Organic Extractables of Internal Surfaces—IC/GC/FTIR for Gas Distribution Systems Components"

Materials Guidelines

Stainless steel is the industry-preferred material for UHP products used in gas systems due to the inherent properties of corrosion and oxidation resistance. AISI type 316L (UNS S31603) low-carbon stainless steel is most commonly used in industry due to the resistance to intergranular corrosion following welding or stress relieving.

- Stainless steel bar stock conforms to the following standards:
 - > ASTM A479, "Stainless and Heat-Resisting Bars and Shapes for Use in Boilers and Other Pressure Vessels"
 - > ASTM A484, "Specification for General Requirements for Stainless and Heat-Resisting Bars, Billets, and Forgings"
 - > ASTM A276, "Stainless and Heat-Resisting Bars and Shapes"
- Plastic material chemical composition is in accordance with:
 - > ASTM D3294, "Standard Specification for PTFE Resin Molded Sheet and Molded Basic Shapes"
 - > ASTM D4894, "Standard Specification for Polytetrafluoroethylene (PTFE) Granular Molding and Ram Extrusion Materials" for Type I, Grade 1 polytetrafluoroethylene.
- 316L VAR and 316L VIM-VAR bar stock conform to SEMI F20, "Specification for 316L Stainless Steel Bar, Forgings, Extruded Shapes, Plate, and Tubing for Components Used in General Purpose, High Purity, and Ultra-High Purity Semiconductor Manufacturing Applications".
- Primary steel processing is either argon oxygen decarburization (AOD) or vacuum induction melting (VIM). A secondary remelt operation such as vacuum arc remelt (VAR) may be used for additional cleanliness of wetted components.
- Key requirements of certain elements within the chemical make-up have been tightened by VIGOUR for more consistency of chemical make-up throughout UHP products; see Table 1.

Table 1: VIGOUR Specifications, wt %

Element	316 AOD	316L AOD	316L VAR	316L VIM-VAR
C (carbon)	0.035%~0.050%	0.015%~0.030%	0.015%~0.030%	0.015%~0.030%
S (sulfur)	0.020%~0.030%	0.005%~0.030%	0.005%~0.012%	0.005%~0.010%
Mn (manganese)	1.50%~2.00%	1.00%~1.50%	1.00%~1.50%	0.15%~0.40%

Verifications of stainless steel products include but are not limited to the following:

- Material conformity is verified in accordance with Practice A of ASTM A262, "Standard Practices for Detecting Susceptibility to Intergranular Attack in Austenitic Stainless Steels."
- Chemical composition is verified in accordance with ASTM A751, "Test Methods, Practices, and Terminology for Chemical Analysis of Steel Products."

- Surface quality is verified through ultrasonic testing in accordance with ASTM E214, “Practice for Immersed Ultrasonic Testing by the Reflection Method Using Pulsed Longitudinal Waves”.
- Inclusions are detected by performing a JK Test in accordance with ASTM E45, “Standard Practice for Determining the Inclusion Content of Steel, Method A,” with ratings based on Plate I-r.

Manufacturing and Surface Finish

During manufacturing, dimensions and surface finishes are monitored closely. Each machined component has extremely fine surface finishes, smooth transitions, fully swept flow paths, and square weld ends to minimize the number of entrapped or generated particles.

- Stainless Steel Product—criteria of SEMI F19, “Specification for the Surface Condition of the Wetted Surfaces of Stainless Steel Components” and the procedures of SEMI F37, “Method for Determination of Surface Roughness Parameters for Gas Distribution System Components”
- The wet surface roughness Ra of ultra-high purity stainless steel products after electrolytic polishing is less than 8µin (0.20µm), and the wet surface roughness Ra without electrolytic polishing is less than 15µin (0.40µm).
- VIGOUR roughness numbers published in product catalogs refer to the process mean, or the roughness value that represents the arithmetic average for a given production process in accordance with SEMI F37.
- Surface roughness/finish is verified using a copy machine in accordance with ASME B 46.1, measured using the maximum available length of the joint or valve bore, excluding conical surfaces, intersections or welds.

Electropolishing and Passivation

The wetted surfaces of fittings and valve bodies are electropolished to improve surface conditions and to form a corrosion resistant surface layer of chromium oxide. After electropolishing, all surfaces are passivated to remove free iron.

- Electropolishing processes are based on ASTM E1558, “Electrolytic Polishing of Metallographic Specimens” and are processed using custom fixturing.
- Passivation processes are based on ASTM A380, “Cleaning, Descaling, and Passivation of Stainless Steel Parts, Equipment, and Systems.”
- Verification of electropolishing and passivation is performed in accordance with Table 2.

Table 2: Verification Methods and Specifications

Parameter	Specification	Test Method
Chromium-to-iron (Cr/Fe)	Ratio > 2.0	ESCA (electron spectroscopy for chemical analysis) based on SEMI F60
Chromium oxide to-iron oxide (CrO/FeO)	Ratio > 2.0	
Oxide thickness	≥ 15A	AES (Auger electron spectroscopy) based on SEMI F72
Surface defect analysis	Maximum of 40 defects, over 5 sample areas	SEM (scanning electron microscopy) based on SEMI F73
Appearance	All parts will be highly reflective, mirror-like, with consistent roughness and a uniform, lustrous finish	Finished parts are visually inspected by the unaided eye using additional bright light

Electrochemical Critical Pitting Temperature

The electrochemical critical pitting temperature (CPT) test, based on ASTM G150, “Standard Test Method for Electrochemical Critical Pitting Temperature of Stainless Steels,” is used to determine resistance to localized pitting corrosion. The CPT test measures the temperature at which

the current density increases rapidly beyond a set limit at a set electrical potential. Sodium chloride solution is used, and electrical potential is held constant in the passivation region. The critical corrosion temperature should be greater than 13°C.

Cleaning and Drying

The DI water cleaning system is closed to the outside environment and thereby limits particle contamination. Products move through a series of ultrasonic washing and multistage DI water rinse tanks to a drying chamber. The DI water characteristics are based on the guidelines of:

- Stainless steel components—SEMI E49.6, “Guide for Subsystem Assembly and Testing Procedures—Stainless Steel Systems”.

Table 3: DI Water Characteristics

Characteristic	Capabilities
Resistivity	≥ 17.5MΩ.cm (25°C)
Total organic carbon (TOC)	< 20ppb
Silica	< 5ppb
Bacteria	< 10 colonies per 100 milliliters
Hot DI water temperature	≥ 60°C

Assembly and Testing

To protect parts from airborne contamination, parts are protected and transported directly from the established cleaning system to a clean environment for assembly and testing.

Packaging and Identification

- SEMI E49.6, “Guide for Subsystem Assembly and Testing Procedures—Stainless Steel Systems” for stainless products.
- Identification and traceability information is visible without opening the product package to reduce the chances for contamination of the product and the system to which it is being assembled.

Scope

This document specifies guidelines used by VIGOUR Company for producing stainless steel products intended for photovoltaic (PV) applications. This document must be used in conjunction with product catalogs, technical bulletins, and reports for complete product information. Application of this document is limited to wetted system components.

Design

Products are designed with specific functional industry standards in mind. Where specific test results exist in the literature, the following standards are applicable:

- Moisture analysis in accordance with ASTM F1397, “Standard Test Method for Determination of Moisture Contribution by Gas Distribution System Components”
- Hydrocarbon analysis in accordance with ASTM F1398, “Standard Test Method for Determination of Total Hydrocarbon Contribution by Gas Distribution System Components”
- Ionic cleanliness in accordance with ASTM F1374, “Standard Test Method for the Determination of Ionic / Organic Extractables of Internal Surfaces—IC/GC/FTIR for Gas Distribution Systems Components.”

Materials Guidelines

Stainless steel is the industry-preferred material for UHP products used in gas systems due to the inherent properties of corrosion and oxidation resistance. AISI type 316L (UNS S31603) low-carbon stainless steel is most commonly used in industry due to the resistance to intergranular corrosion following welding or stress relieving.

Stainless steel bar stock conforms to the following standards:

- ASTM A479, “Stainless and Heat-Resisting Bars and Shapes for Use in Boilers and Other Pressure Vessels”
- ASTM A484, “Specification for General Requirements for Stainless and Heat-Resisting Bars, Billets, and Forgings”
- ASTM A276, “Stainless and Heat-Resisting Bars and Shapes”
- SEMI F20-0305, “Specification for 316L Stainless Steel Bar, Forgings, Extruded Shapes, Plate, and Tubing for Components Used in General Purpose, High Purity, and Ultra-High Purity Semiconductor Manufacturing Applications.”
- Primary steel processing is either argon oxygen decarburization (AOD) or vacuum induction melting (VIM). A secondary remelt operation such as vacuum arc remelt (VAR) may be used for additional cleanliness of wetted components.
- Key requirements of certain elements within the chemical make-up have been tightened by VIGOUR for more consistency of chemical make-up; see Table 1.

Table 1: VIGOUR Specifications, wt %

Element	316 AOD	316L AOD	316L VAR	316L VIM-VAR
C (carbon)	0.035%~0.050%	0.015%~0.030%	0.015%~0.030%	0.015%~0.030%
S (sulfur)	0.020%~0.030%	0.005%~0.030%	0.005%~0.012%	0.005%~0.010%
Mn (manganese)	1.50%~2.00%	1.00%~1.50%	1.00%~1.50%	0.15%~0.40%

Verifications of stainless steel products include but are not limited to the following:

- Material conformity is verified in accordance with Practice A of ASTM A262, “Standard Practices for Detecting Susceptibility to Intergranular Attack in Austenitic Stainless Steels.”
- Chemical composition is verified in accordance with ASTM A751, “Test Methods, Practices, and Terminology for Chemical Analysis of Steel Products.”
- Surface quality is verified through ultrasonic testing in accordance with ASTM E214, “Practice for Immersed Ultrasonic Testing by the Reflection Method Using Pulsed Longitudinal Waves” or through an eddy current test performed in accordance with Swagelok standards.
- Inclusions are detected by performing a JK test in accordance with ASTM E45, “Standard Practice for Determining the Inclusion Content of Steel, Method A,” with ratings based on Plate I-r.

Manufacturing and Surface Finish

During manufacturing, dimensions and surface finishes are monitored closely. Each machined component has extremely fine surface finishes, smooth transitions, fully swept flow paths, and square weld ends to minimize the number of entrapped or generated particles.

- Surface roughness/finish criteria are based on SEMI F19, “Specification for the Surface Condition of the Wetted Surfaces of Stainless Steel Components” and the procedures of SEMI F37, “Method for Determination of Surface Roughness Parameters for Gas Distribution System Components.”
- The wet surface roughness Ra of ultra-high purity stainless steel products after electrolytic polishing is less than 8µin (0.20µm), and the wet surface roughness Ra without electrolytic polishing is less than 15µin (0.40µm).
- VIGOUR roughness numbers published in product catalogs refer to the process mean, or the roughness value that represents the arithmetic average for a given production process in accordance with SEMI F37.
- Surface roughness/finish is verified by using a suitable profiling instrument in accordance with ASME B46.1. Measurements are taken over the maximum available length of the fitting or valve bore, excluding tapered surfaces, intersections, or welds.

Electropolishing and Passivation

This section refers to electropolished products only.

The wetted surfaces of fittings and valve bodies are electropolished to improve surface conditions and to form a corrosion resistant surface layer of chromium oxide. After electropolishing, all surfaces are passivated to remove free iron.

- Electropolishing processes are based on ASTM B912, “Standard Specification for Passivation of Stainless Steels Using Electropolishing” and are processed using custom fixturing.
- Passivation and pre-electropolishing cleaning processes are based on ASTM A380, “Cleaning, Descaling, and Passivation of Stainless Steel Parts, Equipment, and Systems.”
- Verification of electropolishing and passivation is performed in accordance with test methods in section 6 of ASTM B912, “Standard Specification for Passivation of Stainless Steels Using Electropolishing.”

Electrochemical Critical Pitting Temperature

This section refers to electropolished products only.

The electrochemical critical pitting temperature (CPT) test, based on ASTM G150, is used to determine resistance to localized pitting corrosion. The CPT test measures the temperature at which the current density increases rapidly beyond a set limit at a set electrical potential. Sodium chloride solution is used, and the electrical potential is held constant in the passivation region. The critical corrosion temperature should be greater than 10°C.

Cleaning and Drying

The DI water cleaning system is closed to the outside environment and thereby limits particle contamination. Products are cleaned in multistep processes through a series of heated ultrasonic washing, DI water rinsing, and a filtered drying chamber. Cleaning agents are selected in accordance with ASTM G127.

- The DI water characteristics are based on the guidelines of ASTM D5127 Type E-3, “Standard Guide for Ultra Pure Water Used in the Electronics and Semiconductor Industries.”

Table 2: DI Water Characteristics

Characteristic	Capabilities
Resistivity	≥ 12MΩ·cm (25°C)
Total organic carbon (TOC)	< 300ppb
Silica	< 50ppb
Bacteria	< 50 colonies per 100 milliliters

Assembly and Testing

To protect parts from airborne contamination, parts are covered and transported directly from the established cleaning system to a clean work cell for assembly and testing.

Packaging and Identification

- Packaging and identification procedures meet the requirements of SEMI E49.6, “Guide for Subsystem Assembly and Testing Procedures—Stainless Steel Systems” for stainless products.
- products are packaged to keep products free from outside contaminants during shipping. Identification and traceability information is visible without opening the product.

Conversion Factors

Pressure

	atm	bar	ft of H ₂ O	in of hg	in of H ₂ O	kg/cm ²	kPa	mm of Hg	PSI
MULTIPLY	BY								
atm	1.01325	33.932	29.921	407.1827	1.0332	101.3171	760	14.696
bar	0.98692	33.4883	29.530	401.8596	1.019716	100	750.062	14.50368
ft of H ₂ O	0.02947	0.029891	0.882646	12	0.03048	2.9890	22.4198	0.433107
in of hg	0.03342	0.033864	1.1340	13.6	0.034532	3.376895	25.4	0.49115
in of H ₂ O	0.00246	0.002499	0.083333	0.073556	0.00254	0.0249089	1.86832	0.03609
kg/cm ²	0.9678	0.980665	32.8084	28.95903	393.7008	98.03922	735.5592	14.22334
kPa	0.00987	0.010	0.33456	0.29613	4.01472	0.01020	7.5006	0.14504
mm of Hg	0.00132	0.001333	0.044603	0.03937	0.535240	0.001360	0.133322	0.019337
PSI	0.06805	0.068948	2.3089	2.0360	27.70851	0.070307	6.89465	51.175

Flow

	cm ³ /min	cm ³ /sec	ft ³ /hr	ft ³ /min	m ³ /hr	m ³ /min	L/hr	Lpm
MULTIPLY	BY							
cm ³ /min	0.0166667	0.0021189	0.0000353	0.00006	0.000001	0.06	0.001
cm ³ /sec	60	0.1271340	0.0021189	0.0036	0.00006	3.6	0.06
ft ³ /hr	471.9474	7.865790	0.0166667	0.0283168	0.0004719	28.31685	0.4719474
ft ³ /min	28,316.85	471.9474	60	1.699008	0.0283168	1699.008	28.31686
m ³ /hr	16,666.67	277.7778	35.31467	0.5885777	0.0166667	1000	16.66667
m ³ /min	1,000,000	16,666.67	2118.876	35.31467	60	60,000	1000
L/hr	16.66667	0.2777778	0.0353147	0.0005885	0.001	0.0000167	0.0166667
Lpm	1000	16.66667	2.118876	0.0353147	0.06	0.001	60

Density

	gms/cm ³	kg/m ³	lbs/ft ³	lbs/in ³	lbs/U.S. gal
MULTIPLY	BY				
gms/cm ³	1000	62.428	0.0361273	8.3454
kg/m ³	0.001	0.062428	3.61273 x 10 ⁻⁵	0.0083454
lbs/ft ³	0.0160185	16.018463	5.78704 x 10 ⁻⁴	0.13368
lbs/in ³	27.679905	27.679.9	1728	231
lbs/U.S. gal	0.1198264	119.8264	7.4805195	0.004329

Material Compatibility

Material Compatibility									
Process Gas	chemical formula	materials							
		metal			plastic			synthetic rubber	
		stainless steel	nickel	hastelloy	PCTFE	VESPEL	PFA	FKM	EPDM
Ammonia	NH ₃	1	1	1	1	3	1	3	1
Argon	Ar	1	1	1	1	1	1	1	1
Arsine	AsH ₃	1	2	2	1	0	1	1	0
Boron Trichloride	BCl ₃	2	1	1	1	2	1	1	0
Boron Trifluoride	BF ₃	2	1	1	1	0	1	1	0
Carbon Dioxide	CO ₂	1	1	1	1	1	1	2	2
Carbon Monoxide	CO	1	2	2	1	1	1	2	2
Carbon Tetrafluoride	CF ₄	1	1	1	1	0	1	1	0
Chlorine	Cl ₂	2	1	1	1	0	1	2	3
Diborane	B ₂ H ₆	1	2	0	1	0	1	0	0
Dichlorosilane	SiH ₂ Cl ₂	2	1	1	1	0	1	1	0
Fluorine	F ₂	2	1	1	1	0	1	1	0
Freon 23 Trifluoromethane	CHF ₃	1	1	1	1	0	1	1	0
Freon 116 Hexafluoroethane	C ₂ F ₆	1	1	0	1	0	1	1	0
Germane	GeH ₄	1	1	1	1	0	1	1	0
Helium	He	1	1	1	1	1	1	1	1
Hydrogen	H ₂	1	1	1	1	1	1	1	2
Hydrogen Bromide	HBr	2	1	1	1	0	1	1	0
Hydrogen Chloride	HCl	2	1	1	1	0	1	2	0
Hydrogen Fluoride	HF	2	1	1	1	0	1	1	3
Hydrogen Sulfide	H ₂ S	1	1	0	1	0	1	3	1
Krypton	Kr	1	1	1	1	1	1	1	1
Methane	CH ₄	1	1	0	1	1	1	3	2
Methyl Fluoride	CH ₃ F	1	1	0	1	0	1	1	0
Nitric Oxide	NO	1	1	1	1	0	1	1	0
Nitrogen	N ₂	1	1	1	1	1	1	1	1
Nitrogen Trifluoride	NF ₃	1	1	1	1	0	1	1	0
Nitrous Oxide	N ₂ O	1	1	1	2	1	2	1	1
Neon	Ne	2	2	1	1	1	1	1	1
Oxygen	O ₂	1	1	1	1	1	1	1	1
Ozone	O ₃	2	2	1	1	0	1	2	1
Perfluoropropane	C ₃ F ₈	1	1	1	1	1	1	1	0
Phosphine	PH ₃	1	2	2	1	1	1	1	0
Phosphorus Trifluoride	PF ₃	2	1	1	1	0	1	0	0
Silane	SiH ₄	1	1	1	1	1	1	1	2
Silicon Tetrachloride	SiCl ₄	2	1	1	1	0	1	0	0
Silicon Tetrafluoride	SiF ₄	2	1	1	1	0	1	0	1
Sulfur Hexafluoride	SF ₆	1	1	1	1	0	1	1	1
Tetraethyl Orthosilicate	TEOS	1	1	1	1	0	1	0	0
Trichlorosilane	SiHCl ₃	2	1	1	1	0	1	1	0
Tungsten Hexafluoride	WF ₆	2	1	1	1	0	1	0	0
Xenon	Xe	1	1	1	1	1	1	1	1

Pressure Regulator and Valve Selection Guide

Process Gas	Max Flow (slpm)	Source Valves UA/UB/UC	Max Flow (slpm)	Distribution Valves UA/UB/UC	Max Flow (slpm)	Source Regulator UA/UB/UC	Max Flow (slpm)	Distribution Regulator UA/UB/UC
Nitrogen Dioxide (NO ₂)	60	VDV32 1/2"	60	VDV32 1/2"	4	VSR-510S	4	VSR-100S
					45	VSR-410S	6	VSR-100S
Nitrogen Trifluoride (NF ₃)	75	VDV33 1/4"	60	VDV32 1/4"	5	VSR-510S	6	VSR-100S
					60	VSR-410S	15	VSR-100S HF
	100	VDV33 1/2"	110	VDV32 1/2"	150	VSR-410S	30	VSR-410S
		VDV33 1/4"			400	VSR-210S	75	VSR-210S
	350	VDV38H	500	VDV37 PC	1000	VSR-910S	125	VSR-210S HF
		VDV38H		VDV37 M			250	VSR-210S FC
			VDV39			600	VSR-910S	
Nitric Oxide (NO)	310	VDV33 1/4"	75	VDV32 1/4"	3	VSR-510S	3	VSR-100S
					50	VSR-410S	6	VSR-100S HF
	380	VDV33 1/2"	125	VDV32 1/2"	75	VSR-210S	50	VSR-410S
	VDV33 1/4"					75	VSR-210S	
Nitrous Oxide (N ₂ O)	300	VDV33 1/4" VS	70	VDV32 1/4" VS	3	VSR-510S VS	8	VSR-100S VS
					60	VSR-410S VS	20	VSR-100S HF VS
	500	VDV33 1/2" VS	140	VDV32 1/2" VS	100	VSR-210S VS	35	VSR-410S VS
					150	VSR-210S HF VS	85	VSR-210S VS
	1500	VDV38 VS	750	VDV37 PC VS	500	VSR-210S HF VS	160	VSR-210S HF VS
				VDV37 M VS	1000	VSR-910S VS	320	VSR-210S FC VS
			VDV39 VS			800	VSR-910S VS	
Oxygen (O ₂)	250	VDV33 1/4"	75	VDV32 1/4"	10	VSR-510S	10	VSR-100S
					80	VSR-510S HF	25	VSR-100S HF
	400	VDV33 1/2"	150	VDV32 1/2"	150	VSR-510S HF	50	VSR-410S
		VDV33 1/4"			1000	VSR-210S	120	VSR-210S
			1000	VDV37 PC			200	VSR-210S HF
				VDV37 M			400	VSR-210S FC
			VDV39			1000	VSR-910S	
Perfluoropropane (C ₃ F ₈)	70	VDV32 1/4"	35	VDV32 1/4"	2	VSR-510S	2	VSR-100S
		VDV33 1/4"			20	VSR-410S	4	VSR-100S HF
	125	VDV32 1/2"	60	VDV32 1/2"			20	VSR-410S
Perfluorobutadiene (C ₄ F ₆)	25	VDV32 1/2"	25	VDV32 1/2"	5	VSR-410S-VC2	5	VSR-410S-VC2
Phosphine (PH ₃)	320	VDV33 1/4"	80	VDV32 1/4"	5	VSR-510S	5	VSR-100S
					40	VSR-410S	10	VSR-100S HF
	390	VDV33 1/2"	145	VDV32 1/2"				
	VDV33 1/4"							
Phosphine Mixtures (Nitrogen Balance)	185	VDV33 1/4"	90	VDV32 1/4"	10	VSR-510S	10	VSR-100S
					20	VSR-510S HF	20	VSR-100S HF
	225	VDV33 1/2"	160	VDV32 1/2"				
	VDV33 1/4"							
Phosphorous Pentafluoride (PF ₅)	15	VDV33 1/4"	5	VDV32 1/4"	10	VSR-510S	10	VSR-100S
					20	VSR-510S HF	20	VSR-100S HF
	19	VDV33 1/2"	9	VDV32 1/2"				
		VDV33 1/4"	52	VDV37 PC				
	41	VDV38H		VDV37 M				
			VDV39					
Propane (C ₃ H ₈)	65	VDV32 1/4"	42	VDV32 1/4"	3	VSR-510S	3	VSR-100S
		VDV33 1/4"			50	VSR-410S	5	VSR-100S HF
	115	VDV32 1/2"	75	VDV32 1/2"		VSR-210S	50	VSR-410S

Pressure Regulator and Valve Selection Guide

Process Gas	Max Flow (slpm)	Source Valves UA/UB/UC	Max Flow (slpm)	Distribution Valves UA/UB/UC	Max Flow (slpm)	Source Regulator UA/UB/UC	Max Flow (slpm)	Distribution Regulator UA/UB/UC
Halocarbon 125 (C2HF5)	180	VDV32 1/2"	70	VDV32 1/2"	3	VSR-510S	3	VSR-100S
					25	VSR-410S	5	VSR-100S HF
					75	VSR-210S	25	VSR-410S
							75	VSR-210S
Halocarbon 134A (C2H2F4)	55	VDV32 1/2"	40	VDV32 1/2"	3	VSR-510S	3	VSR-100S
		VDV38			50	VSR-410S	5	VSR-100S HF
					75	VSR-210S	50	VSR-410S
	350	VDV37 PC	230	VDV37 PC			75	VSR-210S
	VDV37 M		VDV37 M					
Halocarbon R218 (C2F8)	35	VDV32 1/4"	20	VDV32 1/4"	3	VSR-510S	3	VSR-100S
		VDV33 1/4"			50	VSR-410S	5	VSR-100S HF
	60	VDV32 1/2"	40	VDV32 1/2"	75	VSR-210S	50	VSR-410S
							75	VSR-210S
Halocarbon C318 (C4F8)	25	VDV32 1/2"	20	VDV32 1/2"	6	VSR-410S-VC2	6	VSR-410S-VC2
Halocarbon C1418 (Octafluorocyclopentene) (C5F8)	7	VDV32 1/2"	7	VDV32 1/2"	3	VSR-410S-VC2	N/A	Regulator not required
Helium (He)	750	VDV33 1/4"	250	VDV32 1/4"	125	VSR-510S	65	VSR-100S
					500	VSR-510S HF	125	VSR-100S HF
	1000	VDV33 1/2"	450	VDV32 1/2"	2000	VSR-210S	275	VSR-410S
							625	VSR-210S
	2500	VDV38H	2500	VDV37 PC			900	VSR-210S HF
				VDV37 M			1200	VSR-210S FC
			VDV39			2500	VSR-910S	
Hexafluoropropane (C3H2F6)	20	VDV32 1/2"	15	VDV32 1/2"	6	VSR-410S-VC2	6	VSR-410S-VC2
Hexafluoropropylene (C3F6)	60	VDV32 1/2"	40	VDV32 1/2"	3	VSR-510S	3	VSR-100S
					50	VSR-410S	5	VSR-100S HF
					75	VSR-210S	50	VSR-410S
							75	VSR-210S
Hydrogen (H2)	800	VDV33 1/4"	300	VDV32 1/4"	125	VSR-510S	65	VSR-100S
					500	VSR-510S HF	125	VSR-100S HF
	1600	VDV33 1/2"	600	VDV32 1/2"	1200	VSR-210S	275	VSR-410S
		VDV33 1/4"					625	VSR-210S
	3000	VDV33 1/4"	3000	VDV33 1/4"			900	VSR-210S HF
		VDV38H		VDV37 PC				
				VDV37 M			1200	VSR-210S FC
			VDV39			3000	VSR-910S	
Hydrogen Bromide (HBr)	155	VDV33 1/4"	55	VDV32 1/4"	1	VSR-510SH	1	VSR-510H
					30	VSR-410S	2	VSR-510H HF
	190	VDV33 1/2"	95	VDV32 1/2"	50	VSR-210SH	30	VSR-410S
		VDV33 1/4"					50	VSR-210SH
Hydrogen Chloride (HCl)	350	VDV33 1/4"	75	VDV32 1/4"	2	VSR-510SH	8	VSR-510H
					90	VSR-410S	20	VSR-510H HF
	500	VDV33 1/2"	150	VDV32 1/2"	150	VSR-210SH	40	VSR-410SH
		VDV33 1/4"			600	VSR-210SH HF	85	VSR-210SH
	2000	VDV38	850	VDV37 PC	2000	VSR-910S	160	VSR-210SH HF
				VDV37 M			300	VSR-210SH FC
			VDV39			800	VSR-910SH	

Pressure Regulator and Valve Selection Guide

Process Gas	Max. Flow (slpm)	Source Valves UA/UB/UC	Max. Flow (slpm)	Distribution Valves UA/UB/UC	Max. Flow (slpm)	Source Regulator UA/UB/UC	Max. Flow (slpm)	Distribution Regulator UA/UB/UC
Fluorine Mixtures (20% maximum F2)	185	VDV33 1/4"	90	VDV32 1/4"	5	VSR-510SH	5	VSR-510H
					50	VSR-510SH HF	10	VSR-510H HF
	225	VDV33 1/2"	160	VDV32 1/2"			50	VSR-410SH
		VDV33 1/4"						
Germane (GeH4)	10	VDV32 1/4"	4	VDV32 1/4"	1	VSR-100S	1	VSR-100S
		VDV33 1/4"			7	VSR-410S-VC2	7	VSR-410S-VC2
	18	VDV32 1/2"	7	VDV32 1/2"				
Germane Mixtures (Nitrogen Balance)	185	VDV33 1/4"	90	VDV32 1/4"	10	VSR-510S	10	VSR-100S
					20	VSR-510S HF	20	VSR-100S HF
	225	VDV33 1/2"	160	VDV32 1/2"	50	VSR-410S	50	VSR-410S
		VDV33 1/4"						
Halocarbon 12 (CCl2 F2)	55	VDV32 1/2"	40	VDV32 1/2"	3	VSR-510S	3	VSR-100S
					50	VSR-410S	5	VSR-100S HF
							50	VSR-410S
Halocarbon 12B2 (CBr2 F2)	15	VDV32 1/2"	15	VDV32 1/2"	5	VSR-410SA	5	VSR-410S-VC2
Halocarbon 13 (CClF3)	140	VDV33 1/4"	40	VDV32 1/4"	3	VSR-510S	3	VSR-100S
					50	VSR-410S	5	VSR-100S HF
	170	VDV33 1/2"	70	VDV32 1/2"			50	VSR-410S
		VDV33 1/4"						
Halocarbon 13B1 (CBrF3)	110	VDV32 1/4"	35	VDV32 1/4"	3	VSR-510S	3	VSR-100S
					50	VSR-410S	5	VSR-100S HF
	190	VDV32 1/2"	65	VDV32 1/2"			50	VSR-410S
Halocarbon 14 (CF4)	10	VDV33 1/4"	50	VDV32 1/4"	10	VSR-510S	5	VSR-100S
					40	VSR-510S HF	15	VSR-100S HF
	200	VDV33 1/2"	100	VDV32 1/2"	80	VSR-510S HF	30	VSR-410S
		VDV33 1/4"			500	VSR-210S	60	VSR-210S
	600	VDV38H	500	VDV37 PC			100	VSR-210S HF
				VDV37 M			250	VSR-210S FC
			VDV39			500	VSR-910S	
Halocarbon 21 (CHCl2F)	25	VDV32 1/2"	15	VDV32 1/2"	5	VSR-410S-VC2	5	VSR-410S-VC2
Halocarbon 23 (CHF3)	115	VDV33 1/4"	145	VDV32 1/4"	10	VSR-510S	10	VSR-100S
					50	VSR-410S	20	VSR-100S HF
	140	VDV33 1/2"	250	VDV32 1/2"			50	VSR-410S
		VDV33 1/4"						
Halocarbon 32 (CH2 F2)	140	VDV33 1/4"	55	VDV32 1/4"	3	VSR-510S	3	VSR-100S
					50	VSR-410S	6	VSR-100S HF
	175	VDV33 1/2"	100	VDV32 1/2"	75	VSR-210S	50	VSR-410S
							75	VSR-210S
Halocarbon 114 (C2 ClF4)	30	VDV32 1/2"	25	VDV32 1/2"	7	VSR-410S-VC2	1	VSR-100S
							7	VSR-410S-VC2
Halocarbon 115 (C2 ClF5)	60	VDV32 1/2"	40	VDV32 1/2"	3	VSR-510S	3	VSR-100S
					50	VSR-410S	5	VSR-100S HF
					75	VSR-210S	50	VSR-410S
							75	VSR-210S
Halocarbon 116 (C2 F6)	60	VDV33 1/4"	40	VDV32 1/4"	3	VSR-510S	3	VSR-100S
					50	VSR-410S	10	VSR-100S HF
	100	VDV33 1/2"	80	VDV32 1/2"	75	VSR-210S	25	VSR-410S
		VDV33 1/4"			125	VSR-210S HF	50	VSR-210S
	275	VDV38	400	VDV37 PC			90	VSR-210S HF
				VDV37 M				
			VDV39			175	VSR-210S FC	
						450	VSR-910S	

Pressure Regulator and Valve Selection Guide

Process Gas	Max Flow (slpm)	Source Valves UA/UB/UC	Max Flow (slpm)	Distribution Valves UA/UB/UC	Max Flow (slpm)	Source Regulator UA/UB/UC	Max Flow (slpm)	Distribution Regulator UA/UB/UC
Acetylene (C ₂ H ₂)	200	VDV33 1/4"	25	VDV32 1/4"	3	VSR-510S	3	VSR-100S
			45	VDV32 1/2"	50	VSR-410S	6	VSR-100S HF
	280	VDV33 1/2"	400	VDV37 PC	75	VSR-210S	50	VSR-410S
				VDV37 M			75	VSR-210S
				VDV39			95	VSR-210S HF
Air	150	VDV33 1/4"	90	VDV32 1/4"	30	VSR-510S	30	VSR-100S
			160	VDV32 1/2"	100	VSR-510S HF	50	VSR-100S HF
	250	VDV33 1/2"		VDV37 M	200	VSR-410S	150	VSR-410S
			890	VDV37 PC	800	VSR-210S	400	VSR-210S
	500	VDV33 1/2"		VDV37 M			600	VSR-210S HF
			VDV39					
Ammonia (NH ₃)	250	VDV32 1/4"	100	VDV32 1/4"	5	VSR-510S	5	VSR-100S
		VDV33 1/4"			50	VSR-410S	30	VSR-100S HF
	450	VDV32 1/2"	225	VDV32 1/2"	75	VSR-210S	60	VSR-410S
					400	VSR-210S	125	VSR-210S
	1000	VDV38	1000	VDV37 PC	600	VSR-210S HF	250	VSR-210S HF
				VDV37 M	1100	VSR-910S	500	VSR-210S FC
			VDV39			1000	VSR-910S	
Argon (Ar)	200	VDV33 1/4"	80	VDV32 1/4"	10	VSR-510S	10	VSR-100S
					100	VSR-510S HF	25	VSR-100S HF
	350	VDV33 1/2"	150	VDV32 1/2"	250	VSR-510S HF	50	VSR-410S
		VDV33 1/4"			600	VSR-210S	100	VSR-210S
	1000	VDV38H	800	VDV37 PC			200	VSR-210S HF
			VDV37 M			400	VSR-210S FC	
			VDV39			1000	VSR-910S	
Arsine (AsH ₃)	140	VDV32 1/4"	55	VDV32 1/4"	5	VSR-510S	5	VSR-100S
		VDV33 1/4"			40	VSR-410S	20	VSR-100S HF
	240	VDV32 1/2"	95	VDV32 1/2"				
Arsine Mixtures (Nitrogen Balance)	185	VDV33 1/4"	90	VDV32 1/4"	15	VSR-510S	15	VSR-100S
					50	VSR-510S HF	50	VSR-100S HF
	225	VDV33 1/2"	160	VDV32 1/2"	150	VSR-410S	150	VSR-410S
		VDV33 1/4"						
Boron Trichloride (BCl ₃)	20	VDV32 1/2"	15	VDV32 1/2"	6	VSR-410S-VC2	6	VSR-410S-VC2
Boron Trichloride Mix (Nitrogen Balance)	185	VDV33 1/4"	90	VDV32 1/4"	15	VSR-510S	15	VSR-100S
					60	VSR-410S	30	VSR-100S HF
	225	VDV33 1/2"	160	VDV32 1/2"			60	VSR-410S
	VDV33 1/4"							
Boron Trifluoride (BF ₃)	115	VDV33 1/4"	60	VDV32 1/4"	5	VSR-510S	5	VSR-100S
					25	VSR-410S	10	VSR-100S HF
	145	VDV33 1/2"	100	VDV32 1/2"			25	VSR-410S
	VDV33 1/4"							
Boron 11 Trifluoride (11BF ₃)	115	VDV33 1/4"	60	VDV32 1/4"	5	VSR-510S	5	VSR-100S
					25	VSR-410S	10	VSR-100S HF
	145	VDV33 1/2"	100	VDV32 1/2"			25	VSR-410S
	VDV33 1/4"							
Butadiene (C ₄ H ₆)	60	VDV32 1/2"	60	VDV32 1/2"	3	VSR-510S	3	VSR-100S
					40	VSR-410S	5	VSR-100S HF

Pressure Regulator and Valve Selection Guide

Process Gas	Max Flow (slpm)	Source Valves UAUB/UC	Max Flow (slpm)	Distribution Valves UAUB/UC	Max Flow (slpm)	Source Regulator UAUB/UC	Max Flow (slpm)	Distribution Regulator UAUB/UC
Hydrogen Chloride Mixtures (Nitrogen Balance)	210	VDV33 1/4"	105	VDV32 1/4"	10	VSR-510SH	10	VSR-510H
					20	VSR-510SH HF	20	VSR-510H HF
	265	VDV33 1/2"	190	VDV32 1/2"	40	VSR-410S	40	VSR-410SH
		VDV33 1/4"						
Hydrogen Fluoride (HF)	20	VDV32 1/2"	20	VDV32 1/2"	5	VSR-410S-VC2	5	VSR-410S-VC2
Hydrogen Selenide (H2 Se)	125	VDV32 1/4"	55	VDV32 1/4"	5	VSR-510S	5	VSR-100S
		VDV33 1/4"			40	VSR-410S	20	VSR-100S HF
	215	VDV32 1/2"	95	VDV32 1/2"			40	VSR-410S
Hydrogen Selenide Mixtures (Nitrogen Balance)	185	VDV33 1/4"	90	VDV32 1/4"	10	VSR-510S	10	VSR-100S
					20	VSR-510S HF	20	VSR-100S HF
	225	VDV33 1/2"	160	VDV32 1/2"	50	VSR-410S	50	VSR-410S
		VDV33 1/4"						
Hydrogen Sulfide (H2 S)	210	VDV33 1/4"	80	VDV32 1/4"	5	VSR-510S	5	VSR-100S
					40	VSR-410S	10	VSR-100S HF
	260	VDV33 1/2"	140	VDV32 1/2"			40	VSR-410S
		VDV33 1/4"						
Krypton (Kr)	105	VDV33 1/4"	50	VDV32 1/4"	20	VSR-510S	20	VSR-100S
					60	VSR-410S	30	VSR-100S HF
	130	VDV33 1/2"	90	VDV32 1/2"			60	VSR-410S
		VDV33 1/4"						
Methane (CH4)	245	VDV33 1/4"	120	VDV32 1/4"	10	VSR-510S	10	VSR-100S
					20	VSR-510S HF	20	VSR-100S HF
	295	VDV33 1/2"	210	VDV32 1/2"	40	VSR-410S	40	VSR-410S
		VDV33 1/4"						
Methanol (CH3 OH)	70	VDV32 1/2"	40	VDV32 1/2"	3	VSR-510S	3	VSR-100S
					50	VSR-410S	5	VSR-100S HF
Methyl Bromide (CH3 Br)	25	VDV32 1/2"	15	VDV32 1/2"	5	VSR-410S-VC2	5	VSR-410S-VC2
Methyl Chloride (CH3 Cl)	60	VDV32 1/2"	45	VDV32 1/2"	1	VSR-100S	10	VSR-410S-VC2
					10	VSR-410S-VC2		
Methylsilane (CH3 SiH3)	200	VDV32 1/4"	70	VDV32 1/4"	3	VSR-510S	3	VSR-100S
					50	VSR-410S	5	VSR-100S HF
	350	VDV32 1/2"	120	VDV32 1/2"	75	VSR-210S	50	VSR-410S
							75	VSR-210S
Methyl Fluoride 甲基氟 (CH3 F)	400	VDV33 1/4"	120	VDV32 1/4"	5	VSR-510S	5	VSR-100S
					50	VSR-410S	10	VSR-100S HF
	490	VDV33 1/2"	200	VDV32 1/2"			50	VSR-410S
		VDV33 1/4"						
Neon (Ne)	215	VDV33 1/4"	110	VDV32 1/4"	20	VSR-510S	20	VSR-100S
					40	VSR-510S HF	40	VSR-100S HF
	260	VDV33 1/2"	190	VDV32 1/2"	300	VSR-210S	100	VSR-410S
		VDV33 1/4"						
Nitrogen (N2)	250	VDV33 1/4"	100	VDV32 1/4"	50	VSR-510S	25	VSR-100S
					50	VSR-710S	50	VSR-100S HF
	400	VDV33 1/2"	200	VDV32 1/2"	250	VSR-510S HF	150	VSR-410S
		VDV33 1/4"			1000	VSR-210S	250	VSR-210S
	1000	VDV38H	1000	VDV37 PC			300	VSR-210S HF
				VDV37 M			300	1300S
				VDV39			400	VSR-210S FC
						1000	VSR-910S	

Product Warranty Service

1. Warranty Term

One year after purchase. For any malfunction of a product purchased from VIGOUR that occurs during the warranty term as a result of failure, at the time of delivery, to fulfill the specifications intended, VIGOUR will repair or replace the product at no charge.

2. Range of Warranty

The warranty is limited to our products that were produced at and delivered from our VIGOUR.

Regardless of the warranty term, this warranty does not cover troubles or accidents, or any customer's opportunity loss, lost profit, secondary damage or damage to anything other than our products, as well as replacement work, readjustment of local machinery or equipment or trial operation by the customer. Safety management associated with the use of a product purchased from VIGOUR and peripheral equipment will be the responsibility of the user.

[Exclusions]

The warranty does not cover any of the following cases, even if it occurs during the term of the warranty.

- 1) Cases where failure occurs resulting from the replacement (maintenance) of parts by a person other than a VIGOUR engineer.
- 2) Cases where failure occurs due to a natural disaster or force majeure.
- 3) Cases where failure occurs due to misuse of the product or not taking the required precautions in handling the product.
- 4) Cases where the product is used or stored in an unsuitable environment.
- 5) Cases where the product is used for purposes other than the designated objectives, the product is used at a range exceeding the range of conditions specified in the design, or a purchased product is modified.
- 6) Cases where corrosion and failure occurs due to external factors or a corrosive liquid.
- 7) Any other case judged to be outside of the responsibility of VIGOUR.

VIGOUR

we offer solutions regarding your ideas!

Website : www.vigourco.com

Add: Floor 2, Building 26, Lane 5355, Beisong Road,
SongJiang District, Shanghai China.

Phone: (86) 021-6760 0902

Email: info@vigourco.com



Scan the QR code to get the
product electronic catalog!

Follow us for more VIGOUR news!

