

Diaphragm Valve

V DV1 Series

VIGOUR

Product Features

- Brass chromed plated body and bonnet for inert, reactive, flammable and oxidizing gas and mixtures up to grade 6.0
- Stainless steel 316L for corrosive gases
- Wide range of inlets / outlets
- Suitable for inlet pressure up to 60 bar, hand wheel design
- Metal-to-metal sealing to atmosphere
- Tested for use with oxygen

Typical Applications

- Component Testing
- Calibration Systems
- Laboratory Pressure Control
- High Pressure Sampling Systems
- Service & Test Equipment



Technical Data

Type:	Diaphragm valve
Inlet pressure:	max. 60 bar
Materials	
Body	see ordering info
Seat:	PEEK
Diaphragm:	Elgiloy®
Filter:	SS316L
Inlet / outlet connection:	1/4"NPT(F)
Temperature range:	-30 C to +74 C
Leak rate:	10 ⁻⁸ mbar l/s He
Orifice:	Φ4mm
Flow capacity:	Cv=0.1
Weight:	0.5 kg

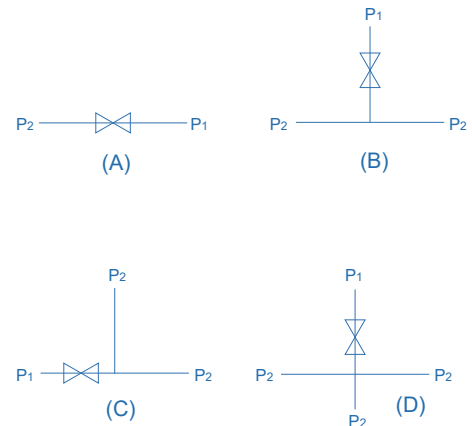

Dimensions (mm)

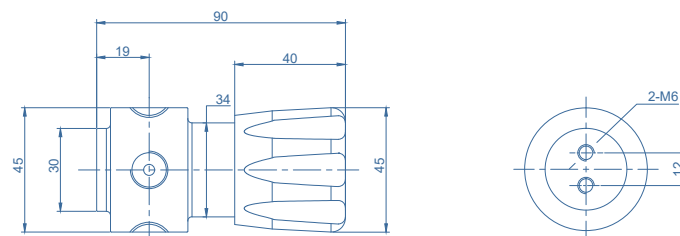

Ordering Information

V DV 1 - C - A - F4 - F4

Body Material

S: 316L

C: Chrome Plated Brass

Inlets / Outlets

F4: 1/4" NPT(F)

F6: 3/8" NPT(F)

Type

A: 2 Ports

B: 3 Ports

C: 3 Ports

D: 4 Ports

